



PURSUIT[®]

"SCIENCE IS THE PURSUIT OF THE UNEXPLAINED"

VOL. 8 NO. 1

JANUARY, 1975

SOCIETY FOR THE INVESTIGATION OF THE UNEXPLAINED

Columbia, New Jersey 07832

Telephone: Area Code 201 496-4366

MEMBERSHIP

Membership is \$10 a year and runs from the 1st of January to the 31st of December. Members receive our quarterly journal PURSUIT, an Annual Report and Auditor's Report, and all special Society publications for that year.

Members are welcome to visit our Headquarters if they wish to use the Library or consult the staff but, due to limited facilities, this can be arranged only by prior appointment; and at least a week in advance.

- YOU DON'T HAVE TO BE A PROFESSIONAL OR EVEN AN AMATEUR SCIENTIST TO JOIN US.

ORGANIZATION

The legal and financial affairs of the Society are managed by a Board of Trustees in accordance with the laws of the State of New Jersey. The Society is also counselled by a panel of prominent scientists, which is designated the Scientific Advisory Board.

IMPORTANT NOTICES

- The Society is completely apolitical.
- It does not accept material on, or presume to comment upon any aspects of Human Medicine or Psychology; the Social Sciences or Law; Religion or Ethics.
- All contributions, but not membership dues, are tax deductible, pursuant to the United States Internal Revenue Code.
- The Society is unable to offer or render any services whatsoever to non-members. Further, the Society does not hold or express any corporate views, and any opinions expressed by any members in its publications are those of the authors alone. No opinions expressed or statements made by any members by word of mouth or in print may be construed as those of the Society.

PUBLICATIONS

Our publishing schedule is four quarterly issues of PURSUIT, dated January, April, July, and October, and numbered as annual volumes – Vol. 1 being 1968 and before; Vol. 2, 1969, and so on. These are mailed at the end of the month. (Subscription to PURSUIT, without membership benefits, is \$5 for 4 issues.) Order forms for back issues will be supplied on request.

PURSUIT is listed in Ulrich's International Periodicals Directory and in the Standard Guide to Periodicals; and is abstracted in Abstracts of Folklore Studies. It is also available from University Microfilms, 300 N. Zeeb Rd., Ann Arbor, Michigan 48106. The price is \$4.10 per reel. An annual index appears in the October issue.

Vol. 8, No. 1
JANUARY, 1975

PURSUIT®

THE JOURNAL OF THE SOCIETY FOR THE
INVESTIGATION OF THE UNEXPLAINED

FOUNDED BY IVAN T. SANDERSON

DEVOTED TO THE INVESTIGATION OF "THINGS"
THAT ARE CUSTOMARILY DISCOUNTED

Editor & Publisher: Hans Stefan Santesson
Executive Editor: Sabina W. Sanderson
Managing Editor: Robert J. Durant
Consulting Editor: Walter J. McGraw

CONTENTS

The Taxonomy of Knowledge	2
Ufology	
The Pendulum Motion of UFOs, by Robert J. Durant	3
The Carbondale (Pa.) UFO, by Robert C. Warth	5
"Project Lure"	5
Chaos and Confusion	
The Hava Supai Canyon "Dinosaur"	6
Pyramidology, by R.J.D.	7
Pyramids, Satellites, and Survival, by M. W. Saunders	8
Pyramids and Mars, by Duncan Lunan	9
Ontology	
Space Probe from Epsilon Boötis, Part II, by Duncan A. Lunan	11
Comment by R.J.D.	16
Biology	
Alas, Poor Jacko, by John Green & Sabina W. Sanderson	18
Pennsylvania ABSMery: A Report, by Robert E. Jones	19
Ivan T. Sanderson's Reconstruction of the Yeti	21
Biological Briefs	22
Anthropology	
The Gizmo, by Ivan T. Sanderson	22
Members' Forum	24
Department of Loose Ends	25
Department of Loose, Loose Ends, by Walter J. McGraw	25
Book Reviews, by Sabina W. Sanderson	26

THE TAXONOMY OF KNOWLEDGE

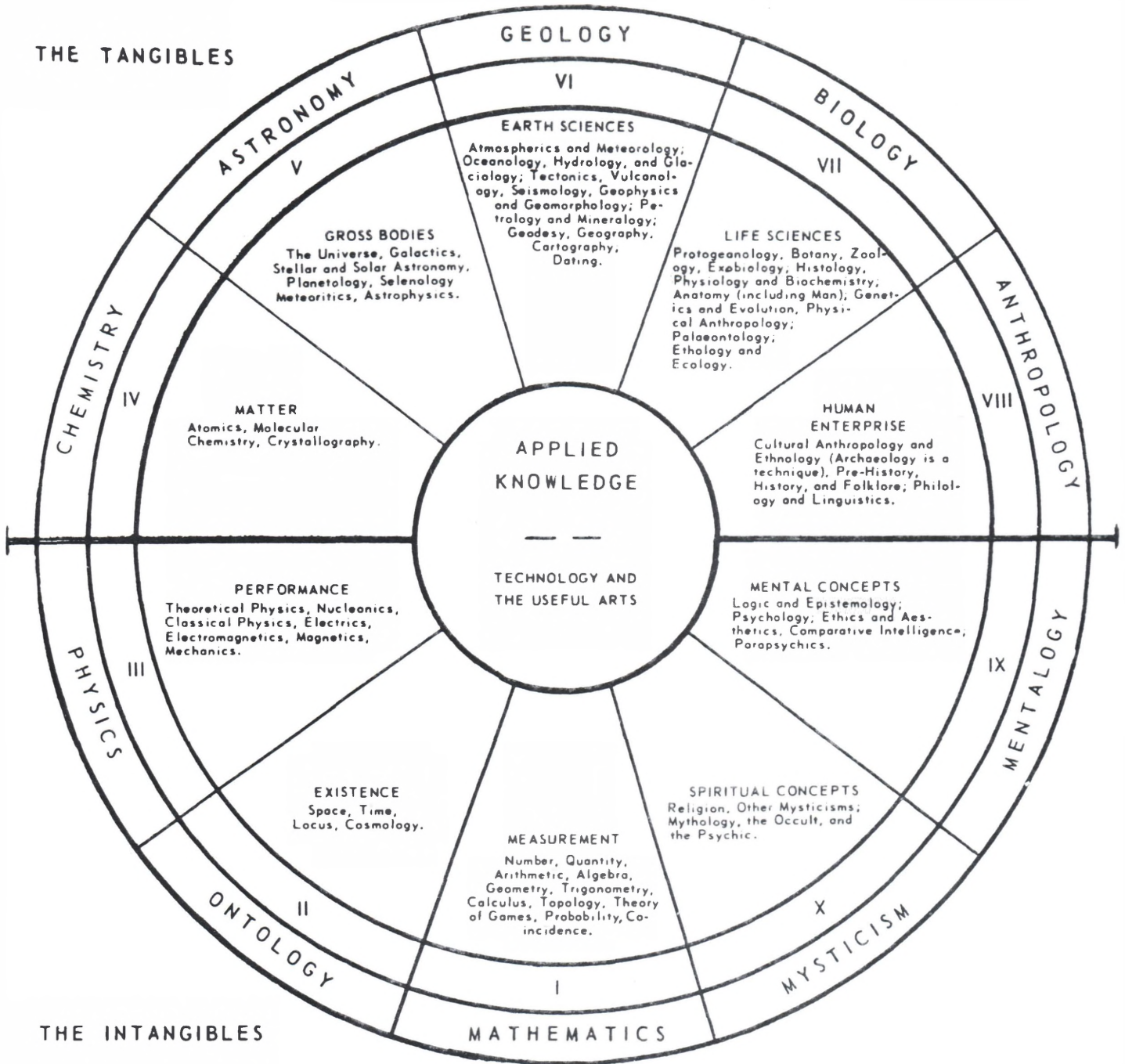

Everything in existence, including "existence" itself, and thus all of our possible concepts and all knowledge that we possess or will ever possess, is contained within this wheel. Technologies and the useful arts lie within the inner circle, having access to any or all of the ten major departments of organized knowledge.

From the KORAN: "Acquire knowledge. It enables its possessor to know right from wrong; it lights the way to heaven; it is our friend in the desert, our society in solitude; our companion when friendless; it guides us to happiness; it sustains us in misery; it is an ornament among friends, and an armour against enemies." - The Prophet.

UFOLOGY

THE PENDULUM MOTION OF UFOs

by Robert J. Durant

UFOs have often been observed rocking back and forth in a pendulum motion. Reports of the pendulum motion seem consistent in ascribing this peculiar flight characteristic to both the landing and takeoff phases, but most often to the regime of flight including the slow ascent to a landing or to a hover close to the surface. Many eyewitness reports refer to a "falling leaf" motion to describe this phenomenon. A close examination of those reports in which this motion is described in some detail reveals that the object's motion can be described as a combination of two separate motions, a downward movement and a rocking motion.

Two explanations have been proposed for this curious flight characteristic. The first to attempt an explanation was Leonard G. Cramp in his book Pieces for a Jig Saw Puzzle. Cramp took the falling-leaf analogy at face value, and wrote that the pendulum motion was caused by the same aerodynamic forces that cause a leaf to rock back and forth as it falls. The same effect may be observed in a coin or other round, flat object falling through a liquid. The cause of this motion is that the lower edge of the falling leaf develops lift in the same manner that an aircraft wing develops lift. As it accelerates through the air, the leading edge, acting as an airfoil, quickly exceeds the critical angle of attack and "stalls". The reverse edge then falls downward and the process is repeated. A series of these accelerations, stalls, and reversals produces the classic falling leaf movement. Cramp thought that the UFOs must at least temporarily be of very small mass, owing to some sort of anti-gravity mechanism, and that therefore the analogy with the leaf ought to hold true.

James M. McCampbell, in his recently published book Ufology, has proposed another explanation for the pendulum motion. He also suggests that the UFOs are powered by an anti-gravity field. A means of losing altitude in a slow and fairly well controlled manner would consist of merely tilting the disc back and forth. At every tilt of the disc some of the "anti-gravity" force would be dissipated in a horizontal direction. Thus with a steady power setting the disc could be gently lowered to the ground by a series of slow tilts. Because of the horizontal force component generated with each tilt, it would be necessary to make complete swings. Otherwise the disc would not fall vertically. In sum, McCampbell interprets the pendulum motion as a very deliberate controlled series of tilts designed to bleed off the earth-repelling force in order to effect descent and landing. See Figure 1.

I have had extensive experience with a crude sort of "anti-gravity" device — the helicopter. In the helicopter the force of gravity is overcome by accelerat-

ing particles of air downward through the rotor blades. By varying the power developed in the rotor system the helicopter may be moved up or down, or held stationary at some distance from the surface. Directional movement is controlled by tilting the rotor system so that a small component of the power from the rotors is directed horizontally. If the power were left unchanged when transitioning from a hover to horizontal flight, the helicopter would settle because of the decreased vertical lifting component. In practice, the pilot merely adds a touch more total power to counteract this tendency.

It does not seem reasonable that a highly advanced craft such as a UFO would be so ill-designed that it would have to accomplish a landing utterly at the whim of gravity and the air, as per Cramp's falling-leaf analogy. Similarly, McCampbell's explanation is predicated on what would appear to be a major and most puzzling design fault in the UFO, an inability to control the total reactive power. The remarks that follow are an attempt to present an alternative hypothesis to explain the pendulum motion of UFOs in a manner that resolves some of the problems that arise from the ideas of Cramp and McCampbell.

We must assume that the UFOs use some sort of force field at least as a means of keeping them from succumbing to the force of gravity, if not in their entire regime of flight. Speculation on the possible nature of this field is beyond the scope of this article. We may, however, gain a better insight into the pendulum motion of the UFOs by using the helicopter analogy and by postulating the existence of such a force field having a few simple characteristics. First, the field must exert a force against other matter, somewhat like the repulsion of similar magnetic poles or of particles with similar electrostatic charges. Second, the field must be generated symmetrically on the underside of the disc. Third, some degree of control of the total reactive force, and of the direction from the disc's vertical axis of the field, is assumed to be exercised by the pilot (human, humanoid, automatic, etc.)

Figure 2 is a side view of such a hypothetical flying device. It is shown in a steady state, motion-

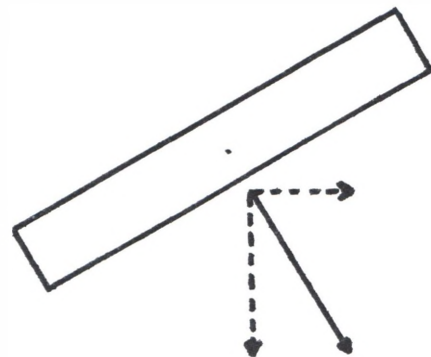

Figure 1

less, a given distance above the surface. The forces tending to lift it are the buoyancy of the enclosed volume in the air, and the reactive force generated within the disc. The force tending to lower the disc is gravity. Two reactive force vectors are shown. These are the average force vectors on either side of the centerline of the disc. As a practical matter, such a force field system would require that the field be generated with its maximum intensity toward the periphery of the disc. Were it concentrated at the center, the object would be extremely unstable. The gravitational pull of the earth is shown by a vector located at the center of gravity of the object.

Now consider what occurs when the disc is tilted, as in Figure 3. The initial tilt could be caused by a gust of wind or other aerodynamic force, or it might

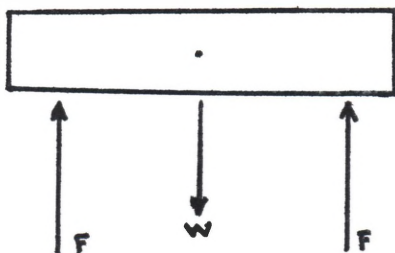

Figure 2

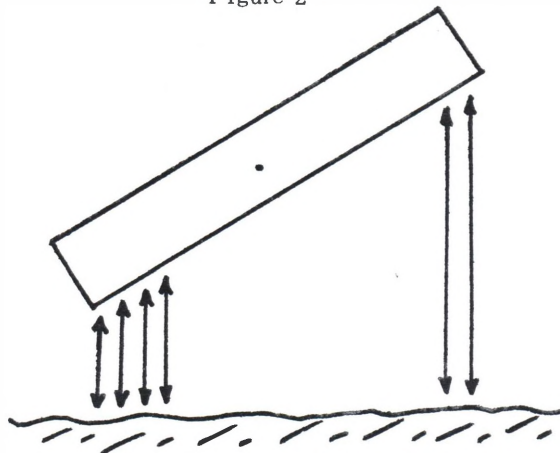

Figure 3

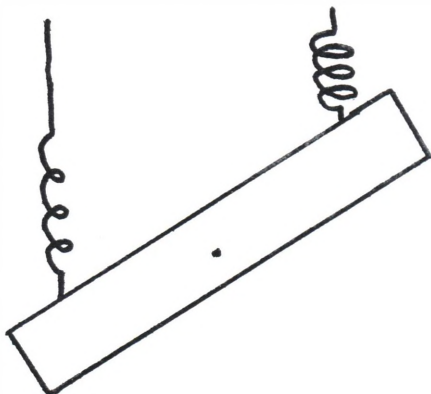

Figure 4

be deliberately induced as part of the control system. With a force field flying device horizontal motion could be accomplished by tilting the field as per the helicopter. It is probable that the disc itself would tend to follow the direction of the field. If this is the case, a UFO in high speed flight should have the leading edge somewhat lower than the trailing edge. Similarly, stopping the craft would cause a pitch up in the direction of flight.

The right side of the disc in Figure 3 would experience an increase in repulsive force, and the left side would have a corresponding decrease. This change in the forces acting on the disc would tend to push the right side up, resulting in a rotation about the center of gravity of the disc. Discounting the frictional forces of the air, once given an initial tilt the disc would rock back and forth indefinitely. Figure 4 is a physical analogy showing a disc hung by two springs.

If the devices shown in Figures 3 and 4 are set in motion and then slowly lowered they exhibit precisely the same motion described by witnesses. Thus this oft-described characteristic of UFO flight is consistent with what one would expect to find in a practical application of a force field type of flying device in the slow, low level phases of flight. One would also expect the UFOs to be essentially "terrain following", i.e., they should maintain approximately the same altitude above the ground as they fly horizontally. This last is confirmed by a number of reports.

During the descent phase the craft would be using relatively low power. Consequently, the period of the oscillations would be relatively large and the tilting easily noticed. This analysis predicts that the pendulum motion will be noticed at any time that the UFO is fairly close to the ground and operating with low power. It follows that a slow takeoff should display the same rocking motion, but there are few reports of this in the literature. The usual case involves a very rapid ascent, implying a high power setting for the reactive field. It would seem to be "policy" for the UFOs to land slowly and gently and to take off rapidly. This makes very good sense from the pilot's point of view.

The pendulum motion has not been observed during rapid ascents. This may be due in part to the rapidity of the event, but it also follows from theoretical considerations that there should not be any discernible oscillations during this phase of flight. The takeoff would require a sudden increase in the field strength. This in turn would proportionately increase the frequency of the oscillations and probably cause some dampening effect on them. The craft would still oscillate, but so rapidly and with such small excursions that it would not be noticed by the observer.

In this discussion it has been assumed that the force exerted by the UFO is, with any given power setting, inversely proportional to the distance of the disc from the surface of the earth. Whether this force follows the laws governing other similar known forces

such as magnetic and electrostatic attraction and repulsion, and gravitational attraction, is a matter for conjecture. It would, however, seem appropriate to suppose that the force generated by the UFOs operates in approximately the same manner as these other forces. Reports of the effects experienced by persons or objects temporarily within the range of the UFO force fields leave no doubt that the field is effective at points between the disc and the surface, but shed little light on the exact nature of the field.

The interpretation given above of the pendulum motion of UFOs would seem to be more comprehensive and perhaps also more in keeping with the practicalities of force field propulsion than the explanations previously advanced. Furthermore, this view of the UFO in low level flight provides a rough mathematical model from which several operating parameters of the UFOs may be deduced if adequate motion picture film of the pendulum motion is obtained.

THE CARBONDALE (PA.) UFO

by Robert C. Warth

On the morning of the 11th November Adolph Heuer alerted Mrs. Sanderson to a radio news report that an unidentified object had allegedly fallen into a pond in Carbondale, Pennsylvania, a few miles northeast of Scranton. She called the police in Carbondale, and Robert Durant and I were then notified and, because of the possibility that a significant find might be made, drove to Carbondale to investigate.

It proved to be impossible even to get the basic facts without variations, and informants living in Carbondale are still investigating the incident for us. However, the story is generally as follows:

On Saturday, the 9th November 1974, at approximately 7:00 p.m. something, variously described as a sparkling flare, a meteorite, or a disintegrating glowing object, fell nearly vertically into a silt pond (surrounded by banks of slag deposits from local coal mines) at the southeastern end of Carbondale. The teenagers (number uncertain) who saw it reported that it fell from a height of perhaps 500-600 feet. They were standing on the summit of a low hill in a cemetery and watched across the corner of an athletic field toward the adjacent pond, which is approximately 150 by 350 feet and perhaps 15 feet deep at its deepest point. An area of the pond, approximately 15 feet across, was said to have glowed throughout the night (for nine hours). It was reported that police tried to retrieve the object with poles (a net in some reports) on Saturday night and again Sunday morning "but it fell to the bottom of the pond".

The immediate area was cordoned off by the local Civil Air Patrol, and the pond partially drained. Scuba divers then investigated the pond and brought up what was described as a "railroad trainman's

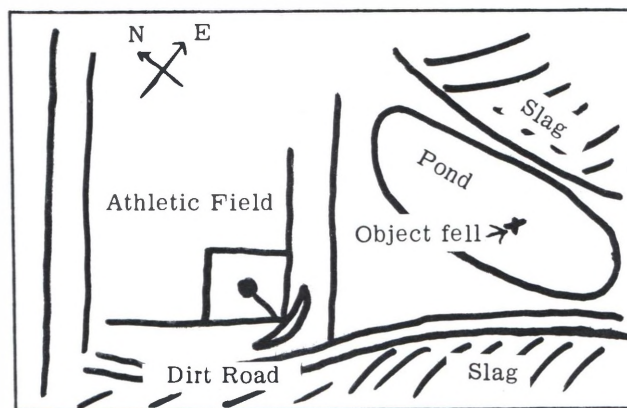

lantern", allegedly still glowing, and reported to be brand new. At a press conference held at 6 p.m. on Monday, Carbondale Police Chief Francis Dottle and Mayor Kaufmann announced that they considered the whole matter a "gigantic hoax" and attributed the whole incident to an unknown youth who tossed the 'railroad lantern' into the pond. This was particularly offensive to the UFO buffs who were awaiting a more convincing (or appropriate) explanation. However, it should be noted that the Carbondale Police had an impossible situation on their hands. Apart from the influx of curiosity seekers, there was some local concern over reports of alleged radioactivity discovered at the site, including a few residents who wanted to know if they should evacuate the area, and the police may well have been under pressure to 'calm things down' by pronouncing the whole incident a hoax.

As is obvious even from this brief report, there are some notable discrepancies in the story. Should further investigation reveal anything worth reporting, we shall include this in our April issue, but at the moment it seems unlikely that anything of significance will be discovered.

"PROJECT LURE"

There has been some little publicity given to a claim by Professor Robert S. Carr that proof would shortly be forthcoming concerning the story, originally published by Frank Scully in Behind the Flying Saucers, of a 'saucer' that crashed near Aztec, New Mexico in 1947. It was alleged to have contained a number of bodies, and both the bodies and the craft were said to have been taken to Wright-Patterson Air Force Base.

Alas for Professor Carr and a number of others who have stated more or less categorically that our Government was going to "confess everything", and specifically to do so on a television program aired the 15th December 1974, nothing of the sort has happened, and there is as yet no proof whatsoever of Scully's story. The TV broadcast contained nothing spectacular.

Professor Carr's other ambitions are to encourage a nationwide appeal to President Ford (who has been interested in UFOs for many years) to outlaw shooting at UFOs, or indeed indulging in other unfriendly behaviour toward them; and to set up a rather monumental complex of buildings and exhibits designed to attract UFOs and their occupants and eventually to

establish proper contact with the latter. The details are included in Chapter 16 of Donald Keyhoe's book Aliens from Space... and we will not repeat them here. This operation is called "Project Lure" and depends on a good many assumptions, which may or may not be justified. Theoretically both ideas are splendid.

CHAOS AND CONFUSION

THE HAVA SUPAI CANYON "DINOSAUR"

We advertised in our last issue for a copy of the report on the Doheny Expedition, and one promptly turned up. The problem here is that a number of sources have stated that the expedition members reported finding a rock carving of a 'dinosaur' in the Hava Supai Canyon—part of the Grand Canyon complex. This proves to be somewhat exaggerated, but we are still working on this and will present a final report either as an addendum here or in a future issue.

The leader of the expedition was apparently a Samuel Hubbard, Honorary Curator of Archaeology of the Oakland (California) Museum, who notes in the "Supplement" to a "new edition" (dated April 1927) of his pamphlet that an "ardent evolutionist has openly accused me of being a 'fundamentalist'". The accusation is certainly justified, though his religious views do not automatically discredit his findings. These latter, however, are not nearly so clear-cut as he would have his readers believe, and in one case—specifically Hava Supai—have got badly muddled by others, e.g. Harold T. Wilkins (in an E. Haldeman-Julius booklet, #B657).

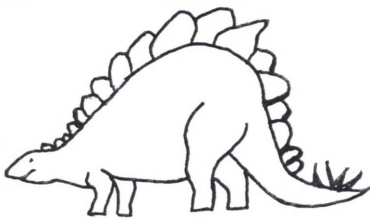

The only "dinosaur" shown in the Doheny Expedition report is reproduced below (a Xerox copy of what is apparently a photograph in the original; with our apologies for the quality). This "sculptured rock" was found east of Portland, Oregon, and is described as being, probably, volcanic tufa, and measuring about 3 feet long and 7 inches thick at the bottom. Details are not discernible in the reproduction available to us at the moment, but Hubbard states "The shape of the head, the prominent eye, and the protruding tongue strongly suggest the lizard or saurian type". Wilkins, on the other hand, says that "The monster shows a formidable array of teeth,..." Hubbard points out, quite correctly, that "Of course there is no way to estimate its age, or to know positively what animal or creature the artist was trying to represent" and then goes on "My own impression is that it is more like the armored dinosaur Stegosaurus than anything I can think of. Originally it may have had both legs and tail". Wilkins tries a bit harder here, stating that "The armoured legs seem to be missing" (emphasis ours). Both plunk for the carving showing a completely armoured body, which so far as we know Stegosaurus did not have (see reproduction). In fact, we don't know what the carving is meant to represent, but we feel that an excessive amount of imagination is required to turn this carving into Stegosaurus.

As for the Hava Supai "dinosaur", Wilkins says that "In the Supai canyon of Arizona, an American expedition, numbering California scientists among its personnel, discovered, in 1924, remarkable pictographs, of unknown and extremely ancient origin, which had been cut through the iron scale on red sandstone, and which depict the most dreadful of all dinosaurs: the terrible tyrannosaurus..." That's not what Hubbard says. What he does say sheds doubt on the whole business; he quotes none other than Col. James Churchward's The Lost Continent of Mu: "... let us consider the Hava Supai Canyon in Arizona. There, drawn and carved on a rock, is a picture of the most terrible carnivorous dinosaur that ever existed on earth, the gruesome Tyrannosaurus of the late Cretaceous Period..."

We have noted before that Col. Churchward is not to be relied on. We are now attempting to trace the source of his information and the drawing of the alleged rock carving. It is clear, however, that the Hava Supai dinosaur was not found by the Doheny expedition.

PYRAMIDOLOGY

Pyramidology is one of the most fascinating, confusing, and longest lived of human activities. It spans the entire gamut from the wildest mysticism to hard mathematical science. Amongst the writers on the problem of the pyramids one can number nearly every species of practitioner of nearly every art and science. There is the most intense controversy surrounding even the methods by which the stones for these edifices were cut, transported, and arranged in place. That such a mundane consideration should still be debated after millenia of study is disturbing enough. But when one considers the more abstract questions concerning the pyramids, such as the reason they were built in the first place, the matter dissolves into chaos. It is as if the pyramids, and most particularly that massive giant rising on the plain of Gizeh, the Pyramid of Cheops, or simply The Great Pyramid, represent one enormous Rorschach inkblot test, calling forth from the collective unconscious of each generation of mankind yet another torrent of imaginative interpretation.

The religious or mystical traditions of pyramidology are preserved and elaborated by a number of organizations still extant and indeed, thriving. SITU does not comment on such matters, and this area is noted only by way of contrasting it with another branch of pyramidology, namely, that which holds that the Great Pyramid was designed as a repository for a very complete body of physical knowledge. The occult tradition has its basis in the Egyptian Book of the Dead, which is perhaps contemporaneous with the Pyramid. The "scientific" tradition finds its genesis in numerical computations found in the same book, and in the historical writings of Herodotus and Agatharchides. Herodotus made it clear that the shape of the pyramid was carefully chosen according to certain geometrical principles, a fact that is remarkable in that all factions in the Pyramid controversy seem agreed to it. Agatharchides, who served as a tutor to an Egyptian king in the second century B. C., stated that the perimeter of the base was designed to equal $\frac{1}{2}$ minute of latitude.

Extremely elaborate and precise measurements of the Pyramid were undertaken in the nineteenth and twentieth centuries. In fact, the Great Pyramid is probably the most carefully measured structure in the world, its sides having been measured on several occasions to an accuracy of one millimeter. As this precise data was produced, it gave rise to a peculiar form of numerical analysis in which the measurements of the sides, height, apothem, all of the included angles, and the sums, differences, and combinations thereof, were cited as proof that the Pyramid was built as a veritable scale model of the Northern Hemisphere.

The base length, for instance, can be shown by

this method to indicate the length of the solar year, accurate to four decimal points. The perimeter, equal to $\frac{1}{2}$ degree of latitude at the equator, the equatorial radius of the earth to a meter, the ratio of polar flattening to within a very small percentage of the currently accepted figure.

The question, of course, is whether the designers of the Pyramid in fact meant to incorporate all these measurements into the geometry of the monument. With the sole exception of the figure for the degree of latitude, which incidentally is surprisingly accurate, there is no hint in the ancient writings that this is the case. Nevertheless, this is no mean feat, and ought properly to put us on guard for other similar data hidden in the Pyramid's structure and measurements. Of course the matter does not lend itself to rigorous proof either way. Given a large enough number of basic measurements, and great flexibility in the manipulation of those numbers, one might very well find any geographical or other relationships. This, in fact, has been the reply of orthodoxy to those who find a mass of quite precise geographical information hidden in the Pyramid. Simply a matter of coincidence, abetted by the tireless manipulation of numbers.

In favor of the hypothesis that the Great Pyramid contains the equivalent of a precise geodetic model of the Earth is the fact that the analogies which are claimed to exist are all in one rather narrow field, namely, the measurements of the earth. This very considerably narrows the operation of the chance factor. In any event, it would seem that the geodetic interpretation of the constructional details of the Great Pyramid deserves a very thorough airing. Unfortunately, the peak of publicity given to this view coincided with a rash of spectacular claims using the measurements as the basis for various prophecies of dire Things to Come. The prophecies, and the prophets, were discredited in short order by the usual method: the prophecies failed to come to pass. The claims for the geodesic nature of the Pyramid were lost in the uproar over the prophecies. Perhaps the baby was thrown out with the bathwater.

Now, just as we were thinking that nothing new could possibly be added to the Pyramid controversy, Mr. M. W. Saunders has written a lengthy paper urging that the Pyramid indicates the position of an orbiting satellite. He has asked that his work be published in Pursuit, and we are pleased to do so. Mr. Saunders intends to publish his entire paper in pamphlet form in the near future. In sum, what Mr. Saunders has done is once again a matter of guesswork, much fooling about with numbers, and the discovery of yet another Pyramid "coincidence." We will leave it to the reader to decide whether this relentless series of "coincidences" may be something else. The analysis of Mr. Saunders' hypothesis written by Mr. Duncan Lunan is quite illuminating in this regard.

R.J.D.

PYRAMIDS, SATELLITES, AND SURVIVAL

By M. W. Saunders

There are three very interesting relationships which can be derived from the Great Pyramid of Cheops in Egypt and the Pyramid of the Sun in Mexico. It may be that these relationships were deliberately incorporated into the structures in order to define a point in space for future generations. The illustration is a schematic representation of the Earth, the Equatorial plane, the Pyramid of Cheops, and the Pyramid of the Sun. The three relationships, as indicated therein are as follows.

First, a straight line extended from the north face of the Pyramid of Cheops intersects the Equatorial plane at a point that is about 20,924 kilometers from the surface of the earth.

Second, a straight line from a point on the ground one cubit from the base of the Pyramid of Cheops, extended through the tip of the pyramid, intersects the equatorial plane at a height of 20,888.2 kilometers.

Third, a straight line from the Pyramid of Cheops in Egypt through the Pyramid of the Sun in Mexico and continued into space intersects the equatorial plane at a height of about 20,884.2 kilometers.

These calculations were based on the following data. The values for height, latitude, and longitude of the Great Pyramid are 0.05 km, 29° 58.75'N, 31° 08'E. For the Pyramid of the Sun the values are 2.29 km, 19° 41.67'N, and 98° 50.67'W. The equatorial radius of the Earth was taken as 6378.16 km, and the polar flattening ratio 1/298.5.

The nominal slope of the north face of the Great Pyramid was assumed to be $4/\pi$, which corresponds to an angle of about 51° 51'14". This is within the measurement tolerance for the angle of this face as given in the standard work on the subject, Petrie's "The Pyramids and Temples of Giza".

The unit of length used for architectural purposes in ancient Egypt was the Royal Cubit. As a result of a great deal of study of ancient units of measurement a quite accurate estimate of this dimension is known today. The calculations presented here use Carter's figure of .5231 meters.

Coles' survey of the Great Pyramid carried out in 1925 supersedes Petrie's work with regard to the dimensions of the base, and confirms that each side of the base is of equal length. Cole's survey gives each side a mean length of 230.364 meters. Using these figures, the "one cubit" observation line was found to subtend an angle of 51° 43'40".

Another interesting "coincidence" is that the height of the "one cubit line" is only 0.17 percent less than forty million cubits, and 0.04 percent more than factorial eleven cubits.

It should be noted that even quite small differences in any of the basic data will greatly alter the height at which the equatorial plane is intersected. If the latitude of either of the pyramid sites is changed by only ½ degree, the height of intersection is changed by about six percent. A change of ½ degree in the slope of the Great Pyramid will have the same effect. If the latitude of the Pyramid of the Sun is increased by slightly more than 10 degrees, or if the latitude of the Great Pyramid is decreased by the same amount, the relationship between these two pyramids would result in no intersection at all.

It would seem, therefore, that there is very little chance factor involved in these most curious relationships and the amazing accuracy with which they point to a position in space about forty million cubits from Earth.

The Pyramid of Cheops by itself indicates the forty million cubit position. The third relationship, i.e., that formed by a line from the Pyramid of Cheops through the Pyramid of the Sun, poses some additional difficulties. In the opinion of archaeologists, the Pyramid of the Sun is approximately 2000 years younger than that of Cheops, and it is therefore rather difficult to imagine that it was built as part of the same general plan for preserving a "message" for the future. There are three possible explanations for this seeming anomaly. First, it might have been decided that at some future time an additional "clue" would be needed, and thus the Pyramid of the Sun was located in the precise location required. Second, it may well be that there was a second indicator built contemporaneously with the Pyramid of Cheops, but

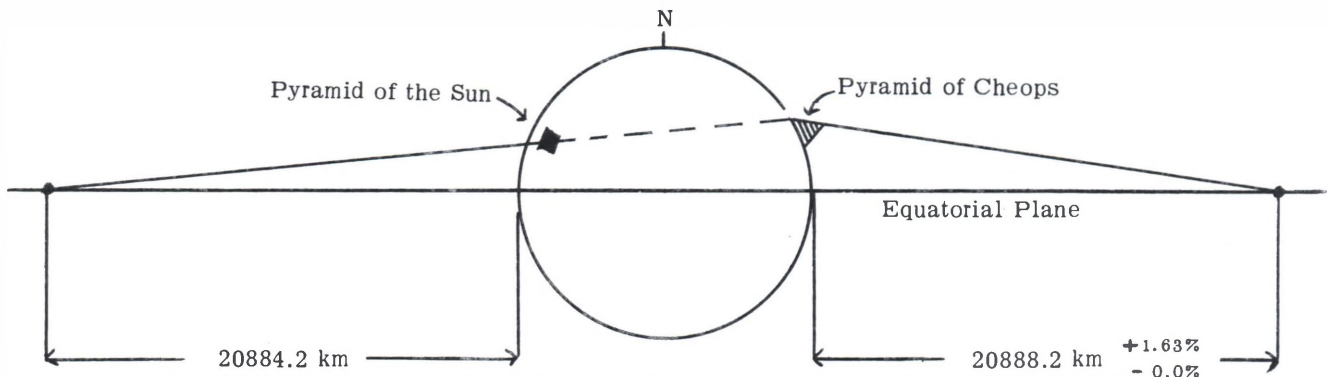

This drawing is diagrammatic.

20888.2 km 40 million builder's units - 0.17%

that it was destroyed by natural cataclysm. Third, the dating of the Pyramid of the Sun might be in error, especially in the sense that the monument now visible could easily have been built over another of very ancient vintage.

In sum, it appears that the intersections on the equatorial plane were planned for some purpose, either by very knowledgeable men in ancient times or by tutelary influences of extraterrestrial origin. Those who sought to leave this information for future generations left no known written records — perishable in any case. Instead, they protected their message in an extraordinarily efficient manner, in vast monuments that have remained virtually unchanged for millennia.

(Editor's note: Mr. Saunders' paper, which is merely summarized above, contains a great deal more data and argument to support his thesis that the equatorial plane intersections were purposefully included in the Pyramid placement and design, and that they probably show the position of an orbiting satellite.)

PYRAMIDS AND MARS

by Duncan Lunan

Mr. Saunders contacted me early in May 1974, having heard through the British Interplanetary Society of my own ideas about a possible space probe from another civilisation orbiting the Earth in a 'Moon Equilateral' configuration. Prima facie, Mr. Saunders' idea that the pyramids indicate an actual satellite struck me as improbable, though I did agree that if Earth has been visited from space in historical times, Giza, Teotihuacan (and Tiahuanaco in Peru) are the most likely Contact centres. My own feeling, from the "Man and the Stars" enquiry, is that Earth has been visited at most four times, two of those being single-ship surveys which had no direct impact on human cultures. The other two, in the Middle East 4000–2500 BC and in the Americas 200–600 AD, would again have been very limited in scope but would have left some traces in the form of legends etc., and possibly have promoted the building of Pyramids to mark the Contact sites. Pyramids are easy to locate from space, especially at sunrise or sunset. As yet, however, there's no proof that Earth has been visited at all.

Mr. Saunders told me that he couldn't suggest any further significance to the fact that the pyramids indicate an orbit at an altitude of 20,884.2 km; so this was the aspect I decided to check. An initial rough look at the orbital period seemed so suggestive that my brother-in-law, David Adams, and I ran the problem on a calculator to attain the greatest possible accuracy.

Mars

The orbital period of a satellite whose orbital radius is known can be calculated by Kepler's Third Law, if both the orbital radius and (sidereal) period of any other satellite are also known. For the basis

of the calculation we took the Moon's mean distance and period to be 384,700 km and 27.322 days. Applying the 3rd Law: $T_1^2/T_2^2 = a_1^3/a_2^3$ (where "T" is the sidereal period, and "a" is the orbital radius) and taking the radius of the Earth to be 6378.16 km, so that a_1 becomes 27,262.397 km, then the sidereal period of the hypothetical satellite is 0.515266 days, i.e. 12.366384 hours.

The correlation which immediately springs to mind is with the diurnal rotation of Mars. The Martian sidereal day is 24h 37m 22.668s, i.e. 24.6227077 hours. Twice the period of Mr. Saunders' satellite is 24.732768 hours. In other words, within the limits of accuracy of the original data (i.e. the altitude of the satellite, and the distance and period of the Moon), it can be said that the satellite is very close indeed to a perfect lock, every two revolutions, with the rotation of Mars. Each Martian day, when Earth came to the meridian of an observer on the Martian surface, the satellite would be correctly placed to transmit data or receive instructions — the orbital period is 3.3 minutes too long for a perfect fit.

But the Earth and Mars do not stand still in their orbits. The above relationship holds only when Mars is at a 'stationary point' in its apparent motion seen from Earth. Each synodic year, as the Earth overtakes Mars, Mars appears to pause in the sky, then move backwards against the prevailing west-east motion of the Solar System, owing to the relative speeds of the two planets. As Earth draws ahead Mars seems to come to rest again, then resumes its west-east motion in the heavens. So if an observer on the surface of Mars found the satellite favourably placed for interrogation over several days, while Mars was 'stationary' as seen from Earth, then the satellite would seem to drift rapidly out of lock as the two planets moved on.

But where is the satellite one synodic year later, when Mars is again 'stationary' seen from Earth? The average synodic year (the time Earth takes to gain 360 degrees on Mars) is 779.94 Earth days, i.e. 760.215 Martian days. In one Martian day the satellite lags 0.11006 hours (6.603618 mins.) behind Mars' rotation. In an average synodic year, therefore, the accumulated lag is 3.398063 Martian days — almost 10 hours too long for an exact repeat of the configuration one synodic year before.

This calculation relates to the average synodic year. Since the orbit of Mars is quite a pronounced ellipse, the synodic year varies cyclically between 765 and 810 Earth days. Accordingly, the satellite transits would be early at some stationary points and late at others. Every 5 synodic cycles (about 75 years) the satellite would be back in the original configuration. The exact drift from perfect recurring lock with the surface of Mars, when Mars is at a 'stationary point', over 5 synodic cycles, is 1.578558 minutes. This is pushing the calculation too far, though — see "accuracy" below.

A "Second" Orbit

By what proved to be a lucky chance, when I first ran the calculation I wrongly took the distance 20 886 km (averaging Mr. Saunders' estimates) to be the orbital radius, instead of the orbital altitude. A satellite at that distance from the Earth has a sidereal period of 0.356972 days, i.e. 8.567328 hours. Three times that, 25.701984 hours, would again be fairly close to Mars-surface-lock; in making three revolutions around the Earth, the satellite lags behind Mars' rotation by 1.07927 hours.

But as said before, Earth and Mars do not stand still. On an ordinary day, i.e. at any time except when Mars appears stationary or retrograde, the satellite has to revolve through a little more than 360 degrees to come back to the same configuration with Mars, and Mars has to rotate through more than 360 degrees to put Earth and satellite back on the meridian of the Martian observer. These two effects run concurrently, so the period of the satellite can be related to either of them, and both are at maximum when Mars is at quadrature seen from Earth, i.e. when the Sun-Earth-Mars angle is 90 degrees. This is a good time for signalling from the Martian point of view, i.e. for simplifying the Martian tracking problem, because when Mars is at quadrature seen from Earth, Earth is at its furthest angular distance from the Sun and at its brightest seen from Mars. The "first" orbit, however, makes it easier for the satellite to track Mars.

The larger of the two quantities (by far) is the extra sidereal rotation Mars has to complete, to bring Earth back to the meridian of a Martian observer on successive days. At quadrature, the extra rotation required is 9.8 degrees, and takes 0.6702848 hours. Thus the satellite's lag behind Mars' rotation, when Mars is at quadrature, reduces to 0.40899 hours in three revolutions; the orbital period is about 8 minutes too long for day-to-day lock. But over an average synodic year, the satellite falls behind by 12.62732 Martian days; after 8 synodic cycles (about 120 years) the original configuration is repeated, with a drift of 27.4194 minutes.

Accuracy

Within the limits of accuracy of the data used in Mr. Saunders' calculations, and of the distance and period of the Moon used in mine, the remaining differences over 75 and 120 years are meaningless; indeed the differences over one average synodic year are probably in the same category. The periods of the outer and inner orbits are, as they stand, within 1 part in 3400, and 1 part in 5200, respectively, of perfect lock with the average synodic year — and that's quite enough to be going on with. A satellite at an altitude of 20,884 — 20,888 km is virtually in perfect recurring lock with the surface of Mars, every two satellite revolutions, every Martian day when Mars is 'stationary' seen from Earth. And a satellite at an orbital radius of 20,884 — 20,888 km is virtually in perfect recurring lock with the surface of Mars,

every three satellite revolutions, every Martian day when Mars is at quadrature.

No Other Planets

Moreover, such a condition is peculiar to the Martian day. No such definitive length exists, to allow two such satellites to be locked with the rotation of any other planet in the Solar System (except Pluto, whose diurnal rotation is unknown). Mercury and Venus are ruled out because of their slow rotation, Uranus because of its very large axial tilt, Jupiter, Saturn and Neptune are ruled out because of their relatively rapid rotations — if a satellite of a given orbital radius is locked to their daily rotation, one of that orbital altitude can only be locked to some multiple of their day.

Hypothetical Satellites

In real life, no satellite at 20,884-8 km radius or altitude would retain its Mars-lock for a significant length of time, without continual correction. At such distances from Earth, the gravitational pulls of the Sun and Moon would have major perturbing effects on satellites' periods. Accuracy to a matter of seconds could hardly be maintained for a single day. Real satellites, if they existed, would simply confuse the issue by drifting out of Mars-lock and ceasing to act as signposts. In other words, the satellites are only hypothetical; their only function would be to act as intellectual signposts from the Pyramids to Mars.

Why Mars?

Why Mars? This question was put up for discussion at ASTRA (the Association in Scotland for Technology and Research in Astronautics) and produced two interesting ideas. (a) The visitors may have assessed our psychology with great accuracy, and realised that reaching our Moon might be too easy for us. After that achievement, we might fall back from space unless given a further incentive. (b) The visitors' chemistry may have been sufficiently unlike our own for Earth life to be lethal to them; e.g. all terrestrial proteins might have been poisonous to them. (It's interesting that in possible drawings of visitors, e.g. at Tassili and Val Camonica, they are apparently shown wearing full pressure suits.) Or dextra DNA instead of laevo might have been the problem. To restock their ships with organic compounds uncontaminated by Earth life, they might have found suitable raw materials on the Martian surface — and if so, the signposts may not be for our benefit. No doubt other suggestions can be put forward.

Teotihuacán-To-Be

Part of Mr. Saunders' hypothesis is that a line projected from Giza through the Earth and through Teotihuacán, happens to meet the equatorial plane at a distance similar to the distances indicated by the Great Pyramid. It is the distance indicated by Giza-Teotihuacán line which provides simple Mars-lock, whether taken as orbital altitude or orbital radius. Now, the Great Pyramid at Giza and the Pyramid of the Sun at Teotihuacán were built at

2,700 years apart (though there seems to be no sign of significant contact with visitors in between). But Mexico is not wide, relative to the circumference of the Earth, and if Mars' day had been just a little different the required line would emerge in the ocean.

One can scarcely suppose that the rotation of Mars was adjusted to make that line cut through Mexico. It might even have been a happy coincidence for the Pyramid makers that the line emerged on dry land. The alternative is that some other relationship was originally expressed linking Giza and Teotihuacán. Even if nothing was built in Mexico at the time, Teotihuacán-to-be could have defined the location of Giza, and not vice versa.

Where On Mars?

Accordingly it seemed worth trying a mirror-image of Mr. Saunders' diagram. A line drawn through the Earth from Giza to Teotihuacan, and on to cut the equatorial plane at the required altitude, emerges from Earth's surface approximately 130 degrees west of Giza at 20 degrees north latitude. A line emerging 130 degrees east of Giza at 20 degrees north, comes up among the Hawaiian islands.

At 20 degrees north latitude on Mars, as it happens, there is a feature geologically similar to Hawaii, though more than twice the size. It is Nix Olympica,

the highest known mountain in the Solar System and largest known volcano. During the Mariner 9 mission its summit crater (25 km above the surrounding plain) was one of the first features to emerge from the dust storm raging when the spacecraft arrived. It might be the best place on Mars to put something intended to survive the storms, and just about the most conspicuous. One might even ask if the Pyramid of the Sun, in particular, consciously imitates its shape.

Conclusion

None of what we've put forward is evidence that there exists a base or cache on Mars, nor indeed that Earth has been visited at all. But in the absence of definite proof that there have been visits, all one can do is to study the possible instances, look for possible correlations, and find out by further research whether they are strong indications of Contact, or merely coincidences. In this instance, probably the next move is to see if there's anything in the Maya or ancient Egyptian cultures to reinforce the 'sign-posts' to Mars. The Maya observed Mars, according to Coe's "The Maya" (Thames & Hudson, 1966), but that's not enough. The 260-day count in their calendar is interesting, being very near to one-third of Mars' synodic year. It might also be interesting to see if anything strange comes to light about Hawaii.

II. ONTOLOGY

SPACE PROBE FROM EPSILON BOÖTIS (Continued from Pursuit, October 1974)

by Duncan A. Lunan, M.A.

In May 1929 a French expedition was in Indo-China to make observations during an eclipse of the Sun. J. B. Galle and G. Talon, captain of the naval vessel 'Inconstant', had orders to study the effects of the eclipse on radio propagation, especially with respect to long-delayed echoes (10). Their equipment was a 500-watt short-wave transmitter, with a 20-metre aerial attached to an 8-metre mast, powered by the generators of the Indo-China Hydrographic Service vessel 'La Perouse'. Two dots were transmitted together every 30 seconds on 25 metres, varied in a fixed musical sequence in order to identify the echoes. (It was still found that the echo frequency was exactly that of the transmitted signal). The receiving equipment included an oscilloscope display, but the observers found the echoes could be plotted more accurately by ear. Two observers worked together, one listening to a speaker, the other with headphones, to ensure the accuracy of the results, and all the published sequences, over a period of 3 days, were recorded by the same observer.

In their preliminary report (11), Galle and Talon said that echoes ceased altogether for the duration of the eclipse, and some later authors have repeated this statement(12); more accurately, however, echoes

ceased at 13h 51m and began again at 13h 54m 29s. The duration of the eclipse was from 13h 53m 45s to 13h 58m 25s and similar pauses occurred in the echo sequence at other times during the day.

The delay times ranged from 1 second to 30 seconds, though two 31-second echoes and one 32-second echo were heard between 15.40 and 16.00 on the day of the eclipse. The occurrence of 1 and 2-second echoes might seem to disprove the hypothesis of a space probe in the Moon's orbit, but for an extraordinary circumstance. At 14h 19m 29s on the day of the eclipse the operator 'forgot' to send the signal, but echoes came in at 5 seconds and 10 seconds nevertheless. From this Galle concluded that some of the weak echoes might have delays of 40 seconds or longer; reading between the lines, it seems that the weak echoes were too faint for the identifying musical tones to be distinguished. It is possible, therefore, that the probe had begun to anticipate the signals from Earth and was transmitting 'echoes' before the signals reached it.

The full record of 8, 9, and 10 May was published by Galle in 'L'Onde Electrique', Vol. 9, 1930, as a large fold-out supplement. Transcribing it was a massive task, made more difficult by the absence of vertical or horizontal guide-lines. Some guide-lines were supplied on a partial reproduction in the 'Proceedings of the Royal Society of Edinburgh', Fig. 7 (13), but the scale was half that of the 'Onde Elec-

trique' graph in which vertical guide-lines, had they been supplied, would have been 1 mm apart. With practice, however, and repeated checking, I was able to transcribe the echo sequences for the 3 days into the same system I had used for the October 1928 signals.

A detailed account of the 9 May panels is in preparation. Most important, however, is panel 7; Its main figure, the upright rectangle right of centre, is the only feature of the panels to be conspicuous even in the Galle-Talon diagram.

The starting points are clear: at the top of the figure we have a row of 7 dots, and below it a row of 14 divided into 4, 3 and 7, from which the horizontal line to the right leads into the constellation figure of Bootes—the only time that star figures appear in the first 10 panels of 9 May, and clearly added to the upper right of the diagram by the probe in order to complete the figure. From that starting row, the logical sequence of the main figure is so clear that it can be represented in standard, even colloquial English, as follows:

AB — Start here.

BC — Our home is Epsilon Boötis.

CDE — which is a double star.

FG, GH — We live on the 6th planet of 7

CH,GK,JKL — check that, the 6th of 7—

EM — counting outwards from the sun

FEG,GN — which is the larger of the two.

HO,OP — Our sixth planet has one moon, our fourth planet has 3, our first and third planets each have one.

GQ,QR — Our probe is in the orbit of your Moon.

ST — This updates the position of Arcturus shown in our maps.

The line ST, with its parallelogram frame drawing attention to it, makes an important point: that since the transmission of the star maps in October 1928, more of the probe's systems had come back on-line. Visual sensors were operating, and a check of the critical star map showed that it was outdated. The error could not be eliminated without redrawing panel 7, but a correction was added to bring the panel up to date. If the panels had been recognised and acknowledged in the 1920's, one wonders what other systems might have proved ready to use.

It seems clear that the main figure of panel 7 is meant to be read from right to left. A lesser 7-dot vertical line appears on the left of the main figure, ending at V₁ (the 6th planet's moon is shown), and around the lower part of the panel various lead-in-lines run from left to right, but these add no further information, leading only to the main right-left sequence. The only thing in the main sequence to read from left to right is the starting line, AV. The line U₁V connects 7-planet dots; and the sequences VW, Wx, XY, YZ and X₁Y₁, Y₁Z₁, suggests a connection between the 7th planet and the space probe. This reinforces a tentative interpretation of panel 9, namely that the probe was launched from the 7th planet to maximise the gravitational boost in a swing around the two suns.

The scale of the planetary system is given at extreme left, by the distinctive figure mentioned in connection with panel 4. It seems that the probe makers express planetary distances as we do, using the distance of their planet from the sun as their 'Astronomical Unit', and they give the distance between their 2 suns in terms of that unit so that we can determine its value. Evidently the 2 suns are 7.5 Epsilon Boötis A.U. apart; therefore the E.B.A.U., the orbital distance of the 6th planet, is 1,097,000,000 miles, as accurately as it can be determined from this diagram. The 7th planet, at 1.66 E.B.A.U., is 1,821,000,000 miles from the major sun.

One would like to see some calculations on the stability of such orbits in the Epsilon Boötis system. There was an inference before that both stars were more massive and shorter-lived than the Sun. However, to have a habitable planet at 1,000,000,000 miles during its Main Sequence lifetime Epsilon Boötis would have required a spectral type close to AO, with a Main Sequence lifetime of 10⁹ years or less and, according to modern views on planetary formation, virtually no chance of having planets at all. F₅(7) is the spectral type below which stars have the very slow rotation we associate, tentatively, with the formation of planetary systems. In 'Habitable Planets for Man', Dole puts the upper limit for system habitability at F₂ on the grounds that life must have at least three billion years of Main Sequence sunlight in order to produce an Earth-like atmosphere (14).

For Epsilon Boötis, therefore, there are two possibilities: either the probe's makers were giant creatures, quite unlike ourselves—in which case their probe would not have approached Earth seeking a new home for them—or the 6th planet was not the original home of their race. In panel 7 two lines appear, A₁C₁ and B₁C₁, leading from the second planet to the sixth. It seems possible that the second planet was the probe makers' original home, and later panels contain strong suggestions to that effect.

Incidentally, the totality of the 9 May eclipse no longer seems a matter of importance. The pause which so impressed the observers was only the natural break between panels 8 and 9, and the probe was well launched on the main figure of panel 9 before the totality of the eclipse ended.

In putting forward the suggested interpretations, it has been impossible to keep using qualifying phrases like 'the hypothetical probe', 'assuming it exists', and 'assuming the patterns are in fact intelligible'. In the long run, only confirmation of the probe's existence could establish that the long-delayed echoes were not a natural phenomenon. However many panels appear to yield meaningful, con-

Fig. 6. (Right) One of several sequences recorded on 9 May 1929 interpreted as a presentation of data concerning the possible Epsilon Boötis planetary system (panel 7 in the sequence). For explanation see text.

sistent information, there will always remain a statistical possibility that the dots are randomly distributed and the apparent patterns are illusory. Nothing would be gained, for example, by having other people attempt to solve the same panels from scratch. If 2 people attempt the Times crossword and one fails to solve it, that does not prove that the Times crossword is a natural phenomenon —and if they both produce the same solution, it suggests but

does not prove that that solution is correct. Even less would be gained by submitting the panels to a computer, which could draw all possible lines and all possible curves through the given dots but could not tell which of them were meaningless or trivial. It is quite possible to make nonsense of the panels by drawing lines saying, for example, 'Venus is Mars', but that does not establish that the meaningful interpretations are illusory.

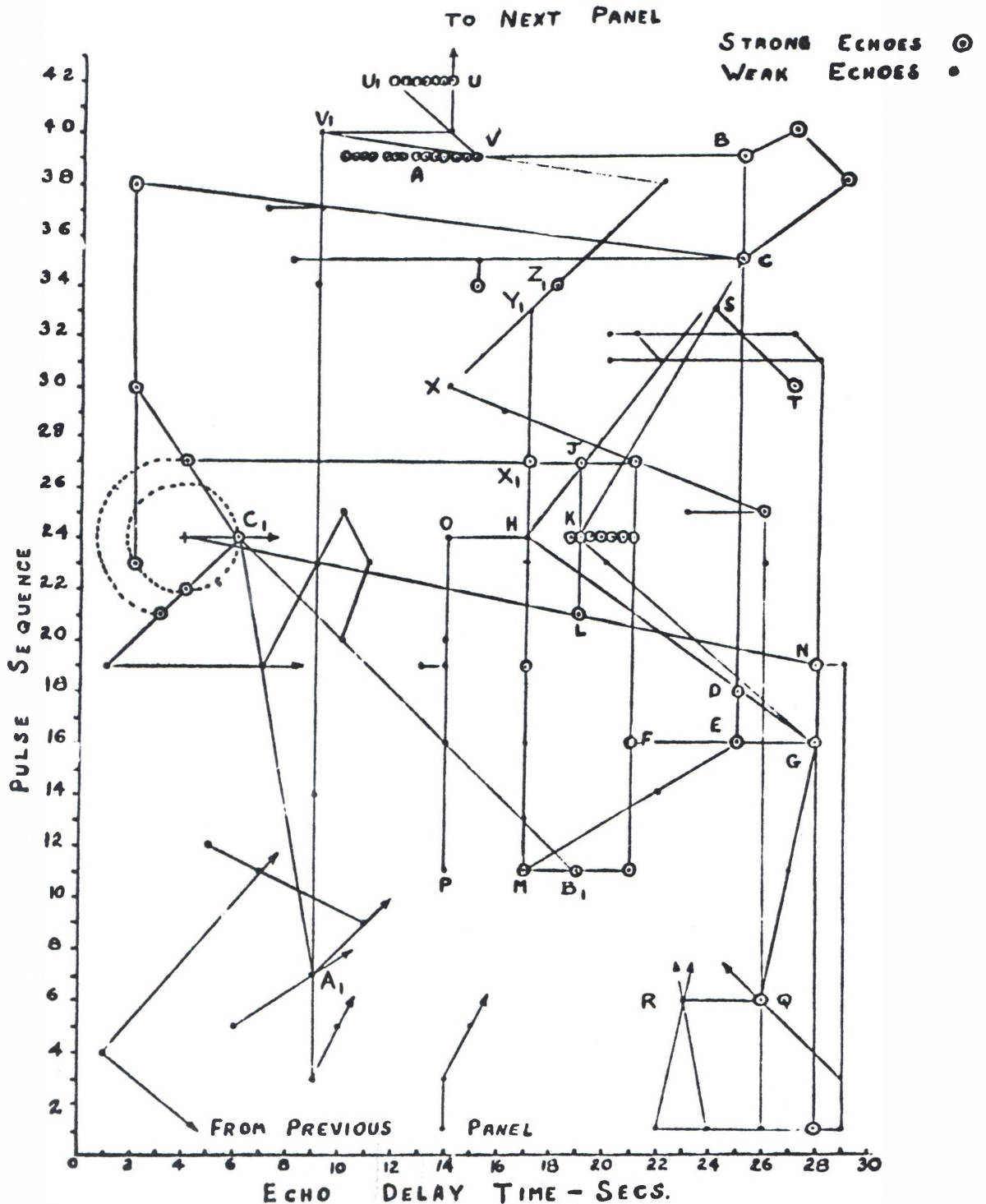

Further Research

There are 18 panels altogether from 9 May 1929, to be solved (I have tentative solutions for 11) and another 12 panels from 10 May which may prove to join up across the 20-minute transmission gaps. (By transmitting 'echoes' of signals from Earth, the probe could at least avoid transmitting when nobody was listening). The 10 panels of 8 May may prove harder to solve, since no distinction between powerful and weak echoes was made in the records. Some of these panels may be 'addressed' to physicists, biologists, etc., rather than to astronomers, and some may defy translation if it is true that the May 1929 signals are the attempt of a society, hundreds of years ahead of our own, to communicate with a culture assumed to be even further ahead. No doubt the interpretation of some panels will remain a source of argument for a very long time.

After May 1929, Störmer stated that no more experiments were carried out for many years. Apparently, however, an extended series of observations was conducted by Appleton and others in 1934; I have not been able to obtain any details of the results as yet. The next attempt to detect long-delayed echoes was apparently that of Budden and Yates in 1947-49, transmitting pulses at 14.5 metres from Ongar in Essex (15). Results were completely negative, partly, perhaps, because there was far more man-made interference on such wavelengths than there had been in the 1920's and 1930's (see later). In 1967, a search for long-delayed echoes was initiated by the Stanford University Institute for Plasma Research, California. Interference from other pulsed transmitters such as Morse and teletype stations remained a major problem, and no results were obtained until January and February 1970, when 3 echoes were heard.

The Stanford researchers are investigating a hypothesis concerning natural long-delayed echoes, summarised by Crawford, Sears and Bruce as follows (12). 'An ordinary wave will propagate to height h_l , and be reflected back to the receiver (not necessarily at the transmitter site). In the reflection region, some energy will couple into longitudinal plasma waves, e.g. due to slight local inhomogeneities. These waves will propagate along the magnetic field lines, with very low group velocity, and will suffer collisional damping, collisionless (Landau) damping, or both. Now assume that some nonthermal electrons are travelling along the field lines. They will amplify the plasma waves by beam-plasma interaction.... We are discussing a relatively complicated mechanism and assuming rather special conditions. Such an explanation is almost certainly demanded, however. It seems likely that at least 2 conditions must occur simultaneously to render LDE (Long-Delayed Echoes) so rare. If we invoke small scale ionospheric inhomogeneity to transfer energy to longitudinal plasma waves, energetic electrons to amplify them, and a further inhomogeneity to transfer energy to longitudinal plasma waves, energetic electrons to amplify

them, and a further inhomogeneity to couple out an ordinary wave signal, the resulting wave mechanism is probably no more complicated than that necessary to account for LDE'.

On 22 January 1970, a single echo was heard. 'The transmitted signal for the first consisted of two 100-msec pulses 1.5 sec. apart. After a 15-sec. delay two similar pulses were received. Their frequencies were, respectively, 55 and 60 Hz lower than the original transmission, and the time interval between them was compressed 25% to 1.1 sec. Neither the frequency shift nor compression effects had been reported previously'. On 14 February 1970, two instances of LDE were detected, about 1½ hours apart: '...the delays were about 20 sec. the echo frequencies were about 100 Hz above the transmitted frequency, and the time spacing decreased 35 and 50% respectively'. Since those first results were announced, the Stanford group have accumulated 20 to 30 records which might be long-delayed echoes. No long sequences have been observed, however, and never more than two echoes in one day (16).

It seems to me that the Stanford research cannot settle the question of the probe's existence or non-existence. Long-delayed echoes have been detected at times when ionosphere conditions match those required by the beam-plasma interaction hypothesis, but have not, as yet, formed any long sequences of echoes without frequency shift or compression in time. Even if a 1920's-type sequence were to be received, it might merely indicate that the probe had been re-activated; even if the sequence could not be resolved into meaningful signals it might still have come from the probe, because we shall be very fortunate if everything we receive from it is immediately comprehensible. And equally, absolute confirmation of the probe's existence would not rule out the possibility that beam-plasma interactions can and do generate natural long-delayed echoes.

If the probe exists, however, it is not likely that we can contact it on wavelengths which are now heavily used for terrestrial radio traffic (and the Stanford results may therefore be genuine beam-plasma interactions). Between 1932 and 1969, according to the radio journal 'QST', there have been more than 40 convincing reports of long-delayed speech echoes on various frequencies (17). (See Table 1). I have also heard that echoes are occurring as interference on communication satellite wavelengths, but have no details as yet. The persistent, 'unimaginative' use of long-delayed echoes strongly suggest that the 1920's echoes were returned by a machine artifact rather than any kind of 'piloted' spacecraft.

Attempts to contact the probe by radio should therefore be made on wavelengths we normally avoid, such as those set aside for radio astronomy. The chances of successfully contacting the probe would in fact improve if powerful radio telescopes such as Jodrell Bank or Arecibo were used, in order to come

nearer to the signal intensity the probe presumably 'expects'.

After its prolonged failure to attract our attention by radio, however, other channels of communication might prove more effective now the roles are reversed. We know that the probe's visual sensors and computing facilities were re-activated by May 1929. Over a distance of a quarter of a million miles, the probe could easily communicate by laser. Attempts might therefore be made to contact the spacecraft by laser probing of the leading Moon Equilateral position. A positive radar blip to aim at would be a great help, but if the probe has an open-framework structure it may be a poor radar target. (However, positive radio contact might cause the probe to use radar enhancement techniques for identification). The laser equipment used in the Apollo lunar reflector experiments could be used for the task, and simple pulses, spaced at 30-second intervals, should be sent in the first instance. The attempts should be made when the Earth is between the probe and the Sun, so that the plasma collector and therefore (we hope) the visual sensors and laser, are pointing towards the Earth. If laser 'echoes' start coming back with varying delays, and especially if they form recognisable star maps, it will be difficult to maintain that they are a natural phenomenon.

References Cont'd.

10 J. B. Galle, 'Observations Relatives a la radio-electricite et a la physique du globe', L'Onde Electrique, 9, 257-265 (1930).

11 J. B. Galle, G. Talon and M. Ferrie, 'Recherches relatives a la propagation des ondes radio electriques effectuees a l'occasion de l'eclipse du 9 Mai 1929', Comptes Rendus, 190, 48-52 (1930).

12 F. Crawford, D. M. Sears and R. L. Bruce, 'Possible Observations and Mechanism of Very Long Delayed Radio Echoes', Journal of Geophysical Research, Space Physics, 75, 34, 1.12.1970, 7326-7332.

13 Stormer, Proceedings of the Royal Society of Edinburgh, 50, Part 11, No. 15 (1933).

14 S. H. Dole, Habitable Planets for Man, Blaisdell Publishing Company, New York, 1964.

15 K. G. Budden and G. G. Yates, 'A Search for Radio Echoes of Long Delay' Jour. Atmos. Terrest. Phys., 2, 272-281 (1952).

16 Private Communication dated 7 Sep. 1972 from Prof. F. W. Crawford, Stanford University Institute for Plasma Research, California, USA.

17 O. G. Villard, Jr., C. R. Graf, and J. M. Lomasney, QST, February 1970.

Postscript, May 1974.

The paper 'Space Probe from Epsilon Boötis' rests on a logical exercise I carried out on the 1920's records in 1972. The full set of interpretations I produced at that time is published in my book, "Man,

and the Stars", which has just appeared in the U.K. (Souvenir Press, London, £3.50) and will be published by Bantam Books in the USA and by Laffont in France. The book summarises an extended series of discussions on interstellar travel and communication, held at ASTRA (the Association in Scotland for Technology and Research in Astronautics) during my term as President. The book is a survey of possibilities and so is largely speculative in scientific terms, e.g. 'if we assume there are habitable planets within 12 light-years, is it feasible to colonise them?' or 'if we assume that faster-than-light travel is possible for the sake of argument, what would an exploration programme be like?'

The star map interpretation has the same hypothetical character, i.e. 'If we assume for the sake of argument the long-delayed echoes come from a space probe, as Professor Bracewell suggested, then can the echo sequences be interpreted as messages?' The resulting interpretations can't be advanced as evidence for the existence of a space probe - that would be a circular argument. Although Kenneth Gatland emphasised the logical status of the argument in printing my paper in 'Spaceflight', there was an initial wave of publicity calling me a scientist or an astronomer, so causing some eminent scientists to reply to my supposed claim to have proved a space probe is up there. Needless to say, I never made such a claim.

Nevertheless a great deal of interest was aroused by the 'Spaceflight' paper, and in the last year there have been a number of major developments.

(1) A Soviet research programme, set up by Professor Kardashev and others to search for signals from other civilisations, has detected trains of pulses from an apparently artificial but unknown source near the Earth. Press statements from the Novosti Agency suggest in all seriousness that the source may be a 'galactic sputnik', i.e. an unmanned probe from another solar system. If 'my' hypothetical probe is also transmitting live signals, its use of 'echoes' as an attention-getting device makes good sense.

(2) Statistical analysis of the dates and times of echo events, from 1927 to 1970, show a striking correlation with the movements of the 'Trailing Equilateral' Lagrange point in the Earth-Moon system. A second source in the Leading Equilateral may also exist, but the association of 'clear' long-delayed echoes with the Equilaterals now seems virtually certain.

(3) A.T. Lawton and S.J. Newton have suggested in 'Spaceflight' that LDE's are generated in space within plasma clouds, by a process analagous to the ionosphere LDE's studied by Professor Crawford (ref.12.) At the very least, therefore, I have pinpointed a previously unknown physical effect in the Earth-Moon system!

(4) We have now established that the true distance of Epsilon Boötis is of the order of 203 light-years,

not 103. It's therefore possible that the two stars are more massive than at first thought, and so too short-lived for intelligent life to appear there. To settle this question we require an accurate modern estimate of the orbital period of the minor sun, but this datum has not yet come to hand. (Assistance welcomed.)

(5) Four articles by Jorgen Hals have been traced, and these add greatly to our knowledge of the 1920's events, including complete records of several experiments. It turns out that my conjectures about the 24.10.28 sequence (fig. 3) are all wrong — Stormer's published record was inaccurate as well as incomplete — and so the fig. 4 and 5 suggestions become very doubtful. However, we now have 9 accurate records, in 4 of which there appears a shape resembling Boötes, along with a line of 7 dots. Taking the 4 supposed maps together, Epsilon Boötis is not the only star emphasised — Delta and Alpha (Arcturus) are similarly picked out.

(6) Accordingly, it comes as a shock that from Tau Ceti, our Sun should appear as a star in Boötes (at bottom right of the constellation) and Arcturus should be displaced upwards and to the left by parallax, i.e. back along the line of its Proper Motion. For a ship coming from Tau Ceti to Earth at relativistic speeds, Alpha, Delta and Epsilon Boötis would be prime navigational references, being orange/red giants near the line of flight.

Tau Ceti is a star like our Sun, 10-12 light-years away, one of the two stars studied for intelligent signals in Project Ozma. If the space probe comes from there it isn't part of a search for new homes conducted by people endangered by their sun, but may well be a response to man's first radio experiments in 1899. My speculative signal interpretations in "Man and the Stars" would be dropped — but a civilisation 10-12 l.y. from us, contemporary with us and already aware of our existence, would be a more dramatic prospect than one 203 l.y. away, 13,000 years in the past and possibly no longer in existence.

(7) Despite technical and other delays some experimental work has been done in the English Project GOLDE (Ground Observed Long Delayed Echoes), but no results have yet been achieved. The present signalling programme is intended to study natural LDE and is not very likely to activate a space probe, if one exists. There is therefore a need for a complementary programme putting out signals designed to catch a probe's attention, and we hope to do this through ASTRA in Scotland.

Comment By R.J.D.

Mr. Lunan's thesis that the long delayed radio echoes recorded by experimenters in the late 'twenties were caused by a satellite has met with considerable opposition on several grounds. First, there is the problem of rather inexact record keeping by the experimenters with the result that there is some ambi-

guity in the graphic presentation of the echoes. Specifically, there are a number of instances in which the echo delay times can be assigned to any one of several pulses sent from the ground station. This has led to a certain amount of "educated guessing" on the part of Mr. Lunan, with a corresponding decrease in the reliability of the dot pictures. This problem, which is freely acknowledged by Mr. Lunan, does not seem to warrant the complete dismissal of his work that has been urged by some individuals. In fact, if we were to apply such a rigorous set of conditions to, say, the translation of Egyptian papyri, there would hardly be a single credible translation extant.

The second objection to the satellite thesis holds that the long delayed echo is a natural phenomenon, somewhat similar to the well known echo of sound or the echo of radio waves reflected from the ionosphere. This view, of course, dismisses a priori the dot pictures and their interpretation by Mr. Lunan. However, it is worthwhile discussing this possibility in some detail.

It should be noted that instances of "unnatural" radio echoes have been recorded on a great number of occasions since the formal experiments cited in Mr. Lunan's study. This is most definitely not a phenomenon observed only by the European investigators during a short period of time and by no other person before or since. However, the experience of Van der Pols, et al, seems unique in that they received a great number of echoes over a very short period of time.

Professor O. G. Villard of the Stanford Research Institute made an appeal to amateur radio operators in the May 1969 issue of QST, The Radio Amateur's Journal, for reports of instances of long delayed radio echoes. These amateurs, as a group, represent an enormous amount of on-the-air time using a variety of operating conditions and frequencies. The results of Villard's survey confirmed the continued occurrence of the LDE phenomenon. The echoes reported were of durations from fractions of a second up to 300 seconds, and the material repeated varied from single words to complete transmissions lasting over three minutes.

In an attempt to determine the nature of the LDE, an experimental radio transmitter and receiver was placed in operation by Crawford, Sears and Bruce at Stanford Research Institute. Apparently this experiment is still being pursued, but the preliminary results were published in the Journal of Geophysical Research, Space Physics, Vol. 75, No. 34. The results were, in this writer's opinion, quite inconclusive, though the claim has been made that the experiment demonstrated not only the existence of the radio LDE but its "natural" genesis as well. The theory advanced to explain the LDE is exceedingly complex, as one might imagine, since it must account not only for very long storage of the initial pulse, but also for its apparent amplification. All of this

must take place in the ionized layers several hundred miles above the surface of the planet.

There is a striking similarity between the problems and results obtained in this experiment and those encountered by ESP researchers. The original design of the equipment proved to be faulty and gave false results. Then, with what the experimenters considered reliable equipment, there was a very long wait for the elusive echoes. A few LDEs did indeed appear, but the number of trial pulses was so great that one might be inclined to dismiss the entire matter in the same way that a few spectacular but "statistically insignificant" ESP results have been dismissed.

While we must give rather low grades to the efforts carried out to date in the investigation of the LDE as a natural phenomenon, the concept is nevertheless most exciting and important in the field of *fortean*. The paradox here is that Mr. Lunan's interpretation is really quite fantastic and earth-shaking, but the "natural" phenomenon alternative might very well be even more spectacular in its implications.

When we refer to a "natural" phenomenon we mean simply that something other than extraterrestrial or supernatural mechanisms are responsible for the observed effects. In other times, the echo of sound was ascribed to occult forces. With the increased study of nature, and of sound in particular, it came to be known that an echo is not caused by some supernatural entity shouting back, but by physical reflection of the waves of pulsating air that comprise sound.

The problem with the radio LDE, as per Lunan, Villard, et alia, is that the darned things take so very long to come back. There are additional technical difficulties having to do with the apparent lack of distortion in the echoes and their unusually strong intensity, both of which would seem to rule out reflection in the ordinary sense. But it is the duration of the quiet period that is the real rub. Could it be that there are LDEs of much greater delay time, possibly of years or decades? Could this phenomenon extend to the entire electromagnetic spectrum instead of being confined to the narrow band of radio frequencies?

Now consider the following. SITU has quite a large file on something commonly called a "mirage". There is indeed a mirage effect that has been rigorously defined by students of optics and atmospheric physics. But our file consists in the main of mirages that cannot be explained by the standard theory, i.e., very complete pictures in the sky of ships that have not sailed for centuries; of naval battles which, if they were fought at all, must have been waged in medieval times; of castles, towns, marching armies. These instances usually have one characteristic in common that absolutely separates them from the temperature-inversion mirage, namely, they are views of something that is not only geographically far removed from the viewer but temporally far removed as well. In a short while the vision disappears. With a bit of luck, one or another of the witnesses is of a

literary bent and records the event for posterity, and with a little more luck it finds its way into our files. The appearance of a stand of date palms in the desert is a fine instance for the textbook version of a mirage, but the entire Spanish Armada over the skies of twentieth century Europe just won't do.

Another anomaly that may be pertinent, but one which we usually ignore as a matter of policy, is the business of "ghosts". These would appear to have something very much in common with the so-called mirages discussed above. However, in order to bring them into this discussion we must first dismiss the two standard explanations for ghosts, that is, that they are the product of overwrought imaginations or the disembodied spirits of once living persons. Might not ghostly apparitions in fact be the long delayed echoes of once living persons or things? This interpretation is not likely to find much favor with any organized group we can think of at the moment, particularly the spiritualists, but it is an interesting speculation in the context of the LDE problem. And it should be pointed out here that ghosts are by no means limited to human forms. There are ghost dogs and cats in great plentitude, and though we hesitate to draw this into the discussion, the occult theories of "primitive" peoples throughout the world abound with a bewildering variety of ghostly fauna. There are ghost ships, and there are ghost cars and bicycles. Because of a bias in favor of the human nature and personal meaning of ghosts a tremendous range of apparitions have been arbitrarily excluded from the list.

In the case of ghosts there is almost always a thing or event that could be identified as the initial tangible impetus, though the temporal incongruity still exists. This also may be true of the mirages. The recurring apparition, whether it be of a nun in 12th Century garb or of a '57 Chevy, is a more or less distinct visual and operative image of the original. Ghosts usually appear to be carrying out a fragment of an ordinary set of activities. That is, the human shapes are seen walking down stairs, not slithering down chimneys. Ghost cars appear on highways, not in living rooms.

Obviously, there is a great deal more that must be determined before making a serious case for the long delayed echo as the cause of this wide range of anomalous data. Can any electromagnetic field persist in this way? Are researchers studying the ionosphere when they ought to be studying the area in the immediate vicinity of the transmitter instead? Do tangible objects have intrinsic "fields" of some sort? We only tentatively propose, to whom it may concern, that the concept of the long delayed echo does seem to lend itself for consideration as a comprehensive means of categorizing a previously disparate set of *fortean* observations.

Addendum

An article in the Christian Science Monitor, reprinted in the Winnipeg Free Press of 4 November

1974, reports on attempts to raise such a probe as is postulated by Mr. Lunan. An 18-foot satellite-tracking antenna was donated by EMI Electronics, the firm for which Mr. Lunan works, and two of his associates, Anthony Lawton and Sidney Newton, listened for the probe on frequencies and in a manner that should have raised it if Mr. Lunan's theory is

correct. They did receive a few delayed echoes, but all were completely random and "clearly due to natural effects". Mr. Lawton, in a paper read to the International Astronautical Congress at Amsterdam, stated that "We would now definitely say that no records to date support the hypothesis that LDE's (the echoes) emanate from an artifact."

VII. BIOLOGY

ALAS, POOR JACKO

by John Green & Sabina W. Sanderson

One of the most famous ABSMal reports concerns 'Jacko', a young Sasquatch-type ABSM stated to have been captured near Yale, British Columbia, on July 3, 1884. The full report is printed in Ivan T. Sanderson's book Abominable Snowmen: Legend Come to Life (pp. 25-26) but we here reprint only portions of the article from The Daily British Colonist, this for benefit of those not familiar with the story.

"Yale, B.C., July 3, 1884—In the immediate vicinity of No. 4 tunnel, situated some 20 miles above this village, are bluffs of rock which have hitherto been unsurmountable, but on Monday morning last were successfully scaled by Mr. Onderdonk's employees on the regular train from Lytton. Assisted by Mr. Costerton, the British Columbia Express Company's messenger, a number of gentlemen from Lytton and points east of that place, after considerable trouble and perilous climbing captured a creature who may truly be called half man and half beast. 'Jacko', as the creature has been called by his capturers, is something of the gorilla type standing about 4 feet 7 inches in height and weighing 127 pounds. He has long, black, strong hair and resembles a human being with one exception, his entire body, excepting his hands (or paws) and feet are covered with glossy hair about one inch long. His fore arm is much longer than a man's fore arm, and he possesses extraordinary strength, as he will take hold of a stick and break it by wrenching or twisting it, which no man living could break in the same way. Since his capture he is very reticent, only occasionally uttering a noise which is half bark and half growl. He is, however, becoming daily more attached to his keeper, Mr. George Telbury, of this place, who proposes shortly starting for London, England, to exhibit him. His favorite food so far is berries, and he drinks fresh milk with evident relish. By advice of Dr. Hannington, raw meats have been withheld from Jacko, as the doctor thinks it would have a tendency to make him savage....

[Jacko was captured by being trapped on a ledge, whereupon one of the men climbed up above him and dropped a rock on his head, "rendering poor Jacko incapable of resistance for a time at least". He was then lowered by rope to the ground.]

"The question naturally arises, how came the creature where it was first seen by Mr. Austin? [near

the track, apparently asleep] From bruises about its head and body, and apparent soreness since its capture, it is supposed that Jacko ventured too near the edge of the bluff, slipped, fell and lay where found until the sound of the rushing train aroused him. Mr. Thomas White, and Mr. Gouin, C.B.E., as well as Mr. Major, who kept a small store about half a mile west of the tunnel during the past 2 years, have mentioned having seen a curious creature at different points between Camps 13 and 17, but no attention was paid to their remarks as people came to the conclusion that they had either seen a bear or stray Indian dog. Who can unravel the mystery that now surrounds Jacko? Does he belong to a species hitherto unknown in this part of the continent or is he really what the train men first thought he was, a crazy Indian?"

This newspaper account was originally pointed out to John Green and Rene Dahinden by a historian. It is an apparently factual report, but John Green is not one to sit polishing his fingernails on his lapel and has continued to search for more information. His report follows:

On the sad side, I have to report the demise of Jacko, the Sasquatch reported caught at Yale in 1884. The historian who originally told Rene Dahinden and me about the article said that there were no newspapers in existence from New Westminster, B.C. at that time, all having been destroyed in a fire. This turns out to be untrue. The B.C. Archives have no copies, but the University of B.C. has microfilm of not one but two newspapers, the British Columbian (now called, oddly, just the Columbian, whereas it is published on the very bank of the Fraser, 300 miles from the Columbia) and the Mainland Guardian. The Columbian reprinted the original story from the Victoria Colonist. Then on July 9 (the article is dated the 7th) the Guardian has a short story from Yale:

"THE 'WHAT IS IT'

Is the subject of conversation in town, this evening. How the story originated, and by whom, is hard for one to conjecture. Absurdity is written on the face of it. The fact of the matter is, that no such animal was caught, and how the 'Colonist' was duped in such a manner, and by such a story, is strange, and stranger still, when the 'Columbian' reproduced it in that paper. The 'train' of circumstances connected with

the discovery of 'Jacko' and the disposal of same was, and still is, a mystery.

REX.

Yale, B.C., July 7, 1884"

REX was a correspondent of the Guardian who was travelling to the Interior and happened to be in Yale at this time. It is interesting to note that neither the Colonist nor the Columbian ever disputed his statements. On the other hand, the British Columbian on July 11 ran a story which the Guardian did not have:

"THE WILD MAN—Last Tuesday it was reported that the wild man, said to have been captured at Yale, had been sent to this city and might be seen at the gaol [American 'jail']. A rush of citizens instantly took place, and it is reported that not fewer than 200 impatiently begged admission into the skookum house. The only wild man visible was Mr. Murphy, governor of the gaol, who completely exhausted his patience answering enquiries from the sold (sic) visitors."

That was all. I finally got a look at the microfilm of the Yale-Kamloops paper for 1884, and found that the publisher was ill at the time of the Jacko story, having already published his last issue from Yale. He did not get back in operation at Kamloops for several months, and his first few issues do not mention Jacko. In fact there was very little Yale news in the paper and I frankly did not search further here.

All this is not 100 percent conclusive perhaps, but I would say 99 percent. At least I'm glad I dug this out myself instead of having it thrown at me by some hostile academic. There probably is no way to overhaul the story now, and various authors will borrow it from one another and reprint it as gospel, but at least the facts as we now know them are on record here.

Thus John Green's report. There are some loose ends of varying importance. One of Ivan Sanderson's statements concerns a reporter who in 1946 "interviewed an old gentleman in Lytton, B.C. who remembered having seen it". John Green tells me that

"The reporter who interviewed the old gentleman at Lytton would probably be me, except that the date would be wrong, as it would have been about 1958. Also the old gentleman didn't say he saw the thing, he (a half-breed who lived on the reservation) said he remembered hearing that the white people had the thing, but did not see it. That is as close as I can get anyway."

A point should be made here. In checking another item (mentioned below) that John Green dug up, I found that the person who compiled notes for Ivan's use in writing Abominable Snowmen—the handwriting is not familiar to me—was not always as precise as he should have been, particularly with regard to dates, and especially when several dates were listed. I think therefore that this alleged report should be ignored.

A very odd item is the reference in the original article to Mr. Gouin, C.B.E. There is no question that the article was published in 1884, but C.B.E. stands for Commander of the Most Excellent Order of The British Empire, which was not established until 1917! I have been unable to find any other meaning for C.B.E. If any of our members can find one, please let us know.

This still leaves the basic question asked by REX: where did the story come from? Despite its precision, naming names and giving a detailed description of Jacko, etc., it seems (unhappily) that it is a fabrication, though possibly based on the remarks made by those who had seen a "curious creature at different points between Camps 13 and 17,...."

The other "item" referred to above concerns A. C. Anderson, an early explorer who is alleged to have reported Sasquatches in 1846. The date is incorrectly given as 1864 in Ivan Sanderson's book, having been picked up by the unidentified hand from an article by Stephen Franklin in Weekend Magazine (4 April 1959). This is almost undoubtedly a simple 'typo', but the story is something else. Franklin quotes from what he describes as an "official letter" (but gives no source) as follows: "...and we were met by a wild giant of the Mountains, who bombarded us with rocks." John Green provides the following information.

The A.C. Anderson report has been for many years the oldest Sasquatch report, although recently eclipsed. Anderson was a Hudson Bay Co. trader who made at least two exploratory trips to try to find a fur brigade route from the interior to the coast to replace the Columbia River route in case (as happened) that became U.S. territory. One trip took him down the Lillooet, Harrison river and lake system and somewhere the story began that on that trip the Sasquatch threw rocks at his party. Anderson's original handwritten report is in the B.C. Archives and it makes no mention of such an incident, nor does the archivist know of any other possible source for the story. Oddly enough, he does mention the Indians showing him a huge footprint, a natural feature in stone about (as I recall) three feet across. Conceivably it might have been a dinosaur print, although none are known in that part of B.C. In any event I have no idea where it might be, but the fact that he mentions it suggests that he certainly would not have failed to mention huge hairy men had he seen any.

We wrote to Stephen Franklin two months ago to ask his source for the 'quotation', but he has not replied.

PENNSYLVANIA ABSMERY: A REPORT

by Robert E. Jones

In September 1974 after almost a year of planning and preparation, SITU launched its first 'official' ABSM "expedition". The venture took a group of us to western Pennsylvania in an attempt to gather more data on what we may call the Eastern species of

what is known in the western United States as Bigfoot.

In September of 1973 SITU learned of a 'flap' of sightings which had been occurring in Westmoreland County in western Pennsylvania throughout the summer months. There had been 145 reports, with some 250 witnesses; footprints were popping up throughout the area; and the police were being deluged with phone calls from frightened residents. Eventually the police turned the problem over to the Westmoreland County UFO Study Group (WCUFOSG) who began to collect data. By the time SITU joined this effort the number of sightings had dropped off to a trickle. However, thanks to the tireless efforts of WCUFOSG, a considerable amount of data was available for study.

In the months that followed, footprints, feces, and hair samples, and taped (alleged) 'screams' of the creature were analyzed by experts. Eyewitness accounts were studied, and theories discussed. I was able to enlist a nucleus of a team, with some modest financial support from SITU to go to Pennsylvania in search of new data that might help to answer some of the questions that our analyses had raised.

The first of three major problems was the approach to be used in searching for the creature and for related data. Here we had to consider four possibilities concerning the 'identity' of the creature, that it is 1) a hoax-hallucination combination, 2) a terrestrial animal, 3) an extraterrestrial (UFO-related) animal, and 4) a type of hologram that could physically affect its environment. Each of these possibilities provided explanations for some of the puzzles that confronted us, but left others hanging. The WCUFOSG favoured the theory that this was a UFO-related phenomenon (an excellent article on this was written by Stan Gordon for the MUFON Journal), but we decided to approach the matter from the standpoint that a terrestrial animal is involved, while keeping our minds open to the other possibilities.

The other two problems were the old standards: manpower and money. There are few people who have not only the desire but also the time, money, and drive to go on such an expedition, and much of the equipment we considered necessary for our study was simply not available due to lack of funds.

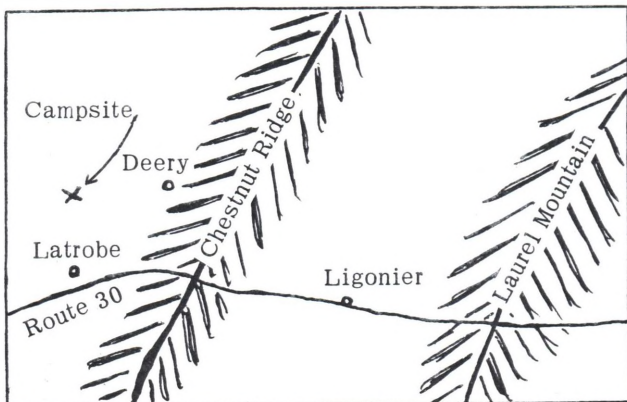

Camp was set up in a park area north of Latrobe, in the heart of the area in which the great majority of sightings had taken place the previous year. From this camp we searched eastward through areas of earlier sightings (see map) and along Chestnut Ridge. We covered the top and western slope of Chestnut Ridge for a distance of approximately ten miles, the pit and mine areas around Latrobe and Deery, and the swamp areas in and around the campsite. We also managed to explore a number of caves in the area, as well as the bottom of the larger lakes in the vicinity, thanks to Dick Laing, the scuba expert on the team. Our searches took us out both during the day and at night, and on several occasions our 'day' lasted sixteen hours. A number of experiments were tried, from baiting and tracking methods, to attempts to lure a creature in by what most would call 'psychic' means. The results were all negative. During the eight days spent in Pennsylvania we did not see an ABSM, nor did we find any positive proof of its existence—nor non-existence.

The closest we may have come to it was one night when we returned to the campsite and were told by two frightened campers (who knew nothing about Bigfoot or of our purpose in being there) of an incident that had occurred ten minutes before we arrived. While asleep in their tent they were awakened by a shrill scream, followed by heavy footsteps of a 'man' crashing through the brush off the hill behind them. When near the tent the 'animal' stopped and emitted a series of grunts and growls, apparently became frightened by the noise inside the tent, and fled back up the hill. The campers were adamant that the gait was bipedal and not that of a quadruped. Ray Naugle (one of our communications experts) and I searched the area thoroughly but aside from some trampled underbrush found nothing definite to corroborate their story.

The lack of physical evidence generally this year is presumably the result of the considerable decline in the number of sightings in the area.

The expedition produced two major results, one theoretical and the other practical.

First, based on our observation of the area we covered—its apparent lack of a sufficient food supply, cover, etc.—it does not seem probable that a terrestrial animal of the reported size and suspected nature of these creatures could exist normally on the surface. We did find that the area is underlain by a very complex network of caves whose ends, in some cases, have not been found. It is, of course, most improbable that the animal spends most of its life deep in caves, but it is possible that it uses them as passages from one place to another. Several of the areas in the eastern United States where the creatures are reportedly seen, contain networks of these 'ad infinitum' caves. This could explain why they seem to 'pop up' in one place and then disappear, reappearing elsewhere without being seen in the intervening areas, but as yet we do not have nearly enough data to draw any conclusions on this. We do, however,

feel that it is something that ought to be looked into.

Our observations did not include Laurel Mountain or the region between the two ridges. We simply did not have enough time, men, or equipment to do so this time, but a start has been made.

The practical result was the experience gained in organizing, planning, and equipping such an expedition. We are already working on plans for future expeditions. Further research and additional equipment are needed, and participation by other SITU

members is encouraged, though potential volunteers must realize that such an expedition is not just "a nice hike in the woods"!

I should like to put on record our thanks to both the people and the governmental agencies in Westmoreland County who were, in every case, both hospitable and helpful, but especially to Stan Gordon and the WCUFOSG for their considerable help during our stay in Pennsylvania.



IVAN T. SANDERSON.
1970
THE ORIGINAL
"ABOMINABLE
SNOW-MAN"
MEH-TEH = "YETI."
OF THE HIMALAYAS.

As promised, here is Ivan T. Sanderson's reconstruction of the Yeti or Meh-teh, the 'original' so-called Abominable Snowman. The reconstruction of the Sasquatch or Bigfoot was included in our October 1974 issue, together with Ivan Sanderson's notes on the reconstructions. He had little to say of the Yeti except that the reconstruction makes "good zoological sense".

BIOLOGICAL BRIEFS

'Self-Awareness' In Rats

The New Scientist of 5 September 1974 contains a brief note on studies reported in the Canadian Journal of Psychology (vol. 28, p. 79) which knock down another alleged distinction between Man and the so-called lower animals. Such things as the use of tools used to be considered as uniquely human, but this has proved to be untrue. Now the New Scientist notes that

"Humans are able to describe their own behaviours and internal states, and this 'self-awareness' has sometimes been regarded as an ability unique to man. But other mammals are also able to distinguish internal states, such as hunger and thirst, by performing appropriate learned responses. A team at the University of Western Ontario—Richard Beninger, Stephen Kendall and C. H. Vanderwolf—have studied the ability of rats to discriminate their own behaviour.

"The rats are hungry and can obtain food by pressing one of four levers in the cage when a buzzer sounds. Which lever they should press depends on what they were doing just before the buzzer sounded. If they were rearing they must press one lever; if they were washing, another; and so on. The Canadian

group find that the rats are able to perform this task very well, so they are evidently aware of their own behaviour..."

It is not known how this awareness is achieved, though there are various theories. Whatever the mechanism, its importance in behaviour is clear: if you don't know what you have been doing, how do you decide what to do next?

More New Animals

Despite periodic announcements that a new species of animal has been discovered, there is still a rather widely held notion that nothing really new is going to turn up, or at least that such finds are rare and concern single species. Probably this is considered to be less true of oceanic life, but one is nevertheless a bit startled to read in the New Scientist (5 September 1974) that a mobile barge oil rig hauled up from its anchorage 130 metres down off the northwest coast of Australia also brought up twelve different species of fish, five of them totally new to science. Dr. Robert Allen, Curator of Fishes at the Western Australian Museum, to whom the catch was sent, noted that "Usually it is impossible to collect specimens at the depths to which the drill penetrated".

VIII. ANTHROPOLOGY

THE GIZMO

by Ivan T. Sanderson

In 1960, Staff Sergeant Peter A. Larsen of the United States Air Force was stationed in England. One day he wandered into an open-air market in Cambridge to do a little browsing. These markets are an ancient tradition in Europe, and especially in England, and into them flows a continuous and incredible mass of material from all over the world, and from all ages. Among the mountains of junk that S/Sgt Larsen glanced over in the Cambridge market was a beautiful old jewel box that he bought for a few shillings. When finally he got the box opened without damaging it, he discovered that it contained some finely carved figurines, a necklace of curious stones, some large seeds wrapped in faded blue paper, and a "something" made of very finely tooled brass, in its own fitted case, in which was pasted a slip stating "Taken from Arabi Pasha's army after Tel-Kebir" (in 1882 presumably).

All this came to our attention through a newspaper article dated the 12th March 1967, the major point of which was that Sgt. Larsen had spent the intervening years trying to find out what the darned thing was. At first he was only mildly curious about the object, but when it proved that no one, from "Smithsonian Institution experts to my neighbors", could identify it, it became something of an obsession with him. Guesses ranged from "a device to time artillery fire to a thermometer for colicky camels".

We made an attempt to get in touch with this gentleman directly, but he had left his last known address and we did not have enough information to enable the National Personnel Records Center in St. Louis, Missouri, to identify him. We had therefore to 'make do' with the drawings and descriptions that accompanied the article.

This 'gizmo' displays several extremely odd characteristics. It is perfectly cylindrical in form, 5 3/4 inches in length, with slightly domed ends that are screwed in and locked at one end with a small lock-screw on the side. At that end, there is a loop to which was still attached a piece of ribbon. On one side, as shown in the illustration, there is a (presumably) glass window which is curved to fit the curvature of the metal cylinder. The whole metal part of the cylinder is striated, as if by engine-tooling, but the portions to left and right of this window are incised around the object whereas, in between, they run longitudinally. Inside the object, as the 'back' of the tube, is a strip of white paper, or other substance, which is very carefully calibrated, as shown. The cylinder is filled with a liquid that is absolutely clear. Within it also is a kind of 'float', most cleverly devised by means of coiled wires that press against the inside of the tube so that, when the device is held upright and suspended from the ribbon, it sinks at a slow and steady rate to the bottom.

As for the calibration and lettering on the 'card' within the cylinder, first there is a small section masked off at the left, as seen in this depiction, and

it is in here that the float rests after the thing has been turned upside down with the handle end at the bottom. Starting from the edge of this blind, the window is equally divided into 25 sections, each of which is halved and quartered. When held upright, with the ribbon end at the top, the float sinks to the bottom—i.e. between No. 24 and the end of the window—in a specified and absolutely regular time, regardless of temperature, barometric pressure, or other factors. The numbering is done in the Egyptian form of Arabic numerals, though some of these are reversed and there is a strange angularity to many (stressed in the formalized reproduction below the drawing of the object).

Inasmuch as this seemed to be an engineering problem we turned to Al Bielek for advice as we always do in such cases. His reply was concise:

“The clue to the nature of the device is in the appended note referring to Arabi Pasha’s army. It must have had some military value, as a timing device. Since present observations indicate that the ‘reel’ or ‘float’ travels from one end of the scale to the other in 7.5 seconds, let us do a bit of computation.

“The velocity of propagation of sound in air (sea level) is 1060 ft./sec. = 0.326 Km/sec.

“If one assumes that the scale markings are in kilometers (a reasonable assumption for the time and place)

$$24 \text{ scale divisions} \times 0.326 = 8 \text{ seconds.}$$

“Considering the age of the device, this is well within observational error and manufacturing tolerances, as they were at that time.

“If one were to observe the flash of an artillery cannon firing, and then listened for the report of the firing, the scale would give a usable range reading directly in kilometers.”

This little mystery would therefore seem to be solved; or, at least, somebody has come up with a possible, and very reasonable, solution. We wonder, however, how it is that nobody was aware of the manufacture of such devices in that period. Perhaps such things were not only known but “common knowledge” at least in the Near East; but why could not anybody identify this example? And just what else, we would ask, has been made and used throughout the years, and centuries, that was commonplace to its users but which completely baffles us today? More has happened in the past than any of us realize.

(If anyone runs across poor Sgt. Larsen, refer him to us. He has stated, “All I know for sure is that it is 85 years old at least. I intend to keep looking for the secret for another 85 years if I must. The blamed thing has me hooked.” We’d like to ‘un-hook’ him. S.W.S.)

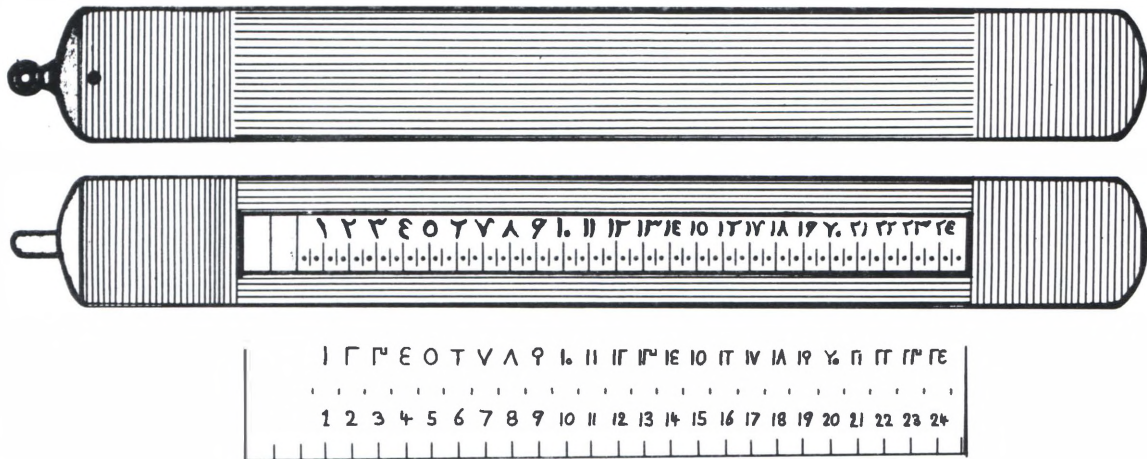

Excuses, Excuses

An AP dispatch from Johannesburg, South Africa, reports some of the ingenious explanations given by motorists on insurance claims for auto accidents, e.g. “The other man altered his mind, so I had to run over him” and “I blew my hooter (horn) but it would not work because it had been stolen”; but what does one do with a chap who announces that “My car had to turn sharper than necessary owing to an invisible lorry (truck)”?

How Useful!

The Bridgeport, Connecticut, Zoning Commission scheduled a meeting in October 1974, and a newspaper reported that “The agenda will include another attempt to rule on the pending proposal to increase the offstreet parking requirement at new apartment developments to space for 1½ cars per apartment.”

For those who may not have seen the announcement elsewhere, Prof. John Wasson of UCLA will pay as much as \$100 for a meteorite if it is a new specimen. If you think you have found one, check to see whether it has a glossy crust on at least one side, a

metal-flecked interior, and is slightly magnetic. If so, send it (or a walnut-sized piece of a large meteorite) to Prof. Wasson at the Institute of Geophysics, UCLA, Los Angeles, California 90024.

DEPARTMENT OF LOOSE ENDS

TUNGUSKA AGAIN

(Editor's Note: In our October 1974 issue we published an article by Daniel H. Harris contending that the Tunguska event was 'nothing more' than a collision between Earth and a very small comet. In fairness to Mr. X, we here publish his rebuttal on this, but will not give more space to this item unless any truly conclusive information comes to hand.)

I did err in stating that "the explosive force released would seem to rule out something with as little mass or density as a comet is believed to have," for I admit that comets may possess the requisite amount of mass but owing to their low density are not likely candidates to explain the explosion that was observed. After Kohoutek's failure to show, it may be more acceptable to blame this on comets, too!

The largest measured nuclei of comets come to about 500 meters according to F. Baldet, V. M. Slipher, and others; and the density of the nuclei ranges about .3 the density of water according to F. Verniadi. Thus, by my rough calculations, a comet could have a mass approaching 40 million metric tons, or enough to cause considerable damage in a collision; and in this respect I am in error. However, I contend that Mr. Harris' claims of their having 1,000-billion tons (by whatever measure) and their having any gravitational effect on the outer moons of Jupiter, asteroids, or their disruption of solar tides. He is obviously mistaking the observations on Lexell's Comet of 1770 and Brooks II of 1886 which showed that there had been 'no observable effect' produced by the comet though it was perturbed greatly, i.e. neither had any significant mass on a planetary scale. The closest substantiation for his claims is William Liller's work in 1957 which made some extremely hypothetical estimates on the iron content of comets; but even so, no significant masses have been observed within any comet's nuclei while between the earth and sun.

I am surprised that Mr. Harris didn't point out to me that the Tunguska event could not have the Pons-Winnecke Comet, which I have since discovered was seen in 1927.

I doubt that a comet's nucleus, even one weighing only 10,000 tons and measuring 20 meters (at least) in diameter at the time of the explosion, would be any more readily acceptable than either a meteorite of stony or metallic composition in providing an explanation of the nature of the blast and the phenomena observed in Europe and not observed elsewhere in the Americas.

From the evidence at the site of the explosion, as observed by Kulik in the patterns of fallen and standing trees with and without branches, there is little doubt of an aerial explosion which the Russians estimated to be at 3 miles altitude. As for the numerous craters, on 12 February 1947, near Vladivostok, Siberia, a spectacular fireball was observed and described as being "as bright as the sun" before its impact. It produced 106 craters, some 30 yards across and 10 yards deep, over a region of nearly 2 square miles. However, in this case the trees fell radially around "each of the large craters", and more than 5 tons of iron meteorite fragments have since been recovered from this site.

While a hyper-velocity collision could vaporize or disintegrate either a meteorite or a comet's nucleus, it still strikes me as odd that there has not yet been any significant finds of condensed iron and magnetite or any dust from a comet, even if it were only a 'dirty snowball' as Whipple suggests.

I do not see any argument in the microbarograph records being the same event, but is Mr. Harris now suggesting that a collision with a comet would be similar to a nuclear explosion? Shock waves and the anomalous propagation of sound could produce the 'four thuds', but they don't necessarily imply a ground impact just because they look like a seismic recording. Remember that the seismic disturbances from the blast lasted for an hour and a half.

DEPARTMENT OF LOOSE, LOOSE ENDS

by Walter J. McGraw

A shattering announcement has come from Michigan State University's Dr. Larry R. Baker.¹ Science/Technology has foisted on the unsuspecting world another "improvement": the seedless pickle. That this is no small matter can be seen from the allegations that the U.S. consumes four million pounds a day. According to the usually reliable Times "That

comes to seven and a half pounds of pickles a year for every man, woman and child, not counting salad cucumbers." (emph. added)

Since (along with many others) salad cucumbers do not agree with me, I realize I do not do my share of pickle consuming.² I also realize (along with, perhaps, a few others) that this might be the greatest

breakthrough since the electric toothbrush. Nevertheless, it would seem that, as with all major steps in Science, this leads us to more uncomfortable questions than Dr. Baker's announcement answers.

(1) Does Science/Technology have the right to force such as the seedless pickle on a referendumless society? One's sensibilities are heightened in this particular area by Dr. Baker's obviously elitist statement: "The pleasure of eating a pickle lies in the crunch, and the region around the seeds is soft and mushy." One feels one must ask this alleged man of science upon what studies is that statement based? Perhaps Dr. Baker's own unscientifically prejudiced pickle proclivities lead him to a crunch-biased conclusion but what Presidential Pickle Commissions have released the definitive findings? What pickle pollsters have been heard from? Where, now that we need them, are the major foundations with their research dollars? When before was seed money so needed as now? Is there no one to speak for those (no matter now small and unattractive a minority they might be) who enjoy the juicy portion of the pickle that Dr. Baker denigrates as "mushy?"

(2) Have the environmental aspects of the seedless pickle been considered? Do we know the sideline effect in decibels of the increased crunch of the new seedless pickle multiplied by four million pounds per day? What could be the synergistic effect if each of those four million pickle pounds were to be crunched simultaneously? In a world already saturated with noise pollution, dare we go ahead without computerized crunch research?

(3) Are we, as a result of this biogenetic tinkering, in danger of being deprived entirely of our pickles? Dr. Baker makes it clear that he envisions, in Michigan,³ a vast seedless pickle monoculture. Has he listened to none of the warnings that our new super-crops could be wiped out by super-pests? Nature abhors not only a vacuum; it also abhors a lack of variety. Could some, as yet, unknown Michigan seedless pickle blight wipe out the Michigan seedless pickle? (This danger will become more real when the implications of point 4 are realized.) Could our precarious economy (to say nothing of our balance of payments deficit) withstand what that would do to

our hamburger industry? Would the entire stock market be far behind if MacDonald's toppled further?

(4) Dr. Baker tells us that these seedless pickles are all to be female. One wonders, does this come as a result of biological demands? Or has a spineless Dr. Baker given in to the more raucous demands now being made by Women's Lib? And is this a path that is going to be followed by the Science/Technology of the seventies? Is this a trend from which warning should be taken by the higher forms of male life? Or even lower forms, such as the male Homo sapiens?

(5) Will devoted pickle eaters (to say nothing of us part time amateurs) be given a choice of seeded vs. seedless pickles? Here the indications are depressing. Economically the female seedless pickle is cheaper to harvest than the good old heterosexual seeded pickle because, like today's female teenager, she ripens in concert with all her sisters. Parents of female teenagers know well the problems this can bring about but when, in this profit oriented culture, have the cries of parents ever softened the hearts of the entrepreneurs? Can we expect the pickle growers of America to be more belabored by conscience than have been, for instance, the pop musical industry moguls?

Only a few years ago this so-called "development" would have been hailed as a "progressive" sign of times when Science/Technology could do no wrong. I think it is a sign we now live in a more enlightened age that this announcement (coming, as it does, from the heartland of America) gives us pause. It is, indeed, a healthy sign that one wonders if appeal should not be made to a Brower, a Gardner or a Nader to help in the forming of a grass roots movement which would have as its slogan—nay, its battle cry: "Kosher Dill Munchers of the World, arise! You have nothing to lose but your seeds!"

1. New York Times, 5/31/71, p. 26
2. One can not discount the possibility that one's delinquencies could be compensated for by some pregnant lady with her midnight portions of vanilla ice cream.
3. Michigan is the nation's largest producer of pickles despite the generally held belief among automobile owners that it produces only lemons.

BOOK REVIEWS

by Sabina W. Sanderson

MISCELLANY

William R. Corliss has now published three volumes in his series of sourcebooks, two on geophysics—Strange Phenomena, vols. G1 and G2—and one on archaeology and anthropology—Strange Artifacts, vol. M1. These are \$6.95 each and are available from the author, address Glen Arm, Maryland 21057. (Maryland residents add sales tax.) All are well worth having.

For those interested in astronomy, if you have not yet seen it, you should take a look at Astronomy, a relatively new magazine. It is beautiful and quite informative. Also rather expensive. Buy a copy at a newsstand or take a look in your local library before deciding whether to subscribe.

A booklet, The UFO Wave of 1896, has been privately printed by Mr. Loren E. Gross, 38675 Paseo

Padre #305, Fremont, California 94536, and is available from him for \$1.00. This contains interesting historical material and seems reasonably complete for the area it covers, i.e. the West Coast.

Those interested in UFO detectors may wish to write to Parsons & Associates, P.O. Box 57, Manchester, Tennessee 37355. They have plans available for several models.

BACK ISSUES OF PURSUIT

There continues to be a demand for back issues, and the current supply is listed below. In addition, a few copies of Volume 2, No. 1, and Volume 3, No. 3 have turned up. First come, first served. (If the supply has been exhausted when your order comes in, we will refund your money, or you may specify substitutions.)

Back issues are \$1.50 each, postage paid.

Vol. 4, nos. 1-3, in good supply
 Vol. 4, no. 4, low
 Vol. 5, no. 1, very low
 Vol. 5, nos. 2 and 3, a fair supply
 Vol. 5, no. 4, low
 Vol. 6, no. 1, low
 Vol. 6, no 2, good supply
 Vol. 6, nos. 3 and 4, low
 Vol. 7, no. 1, low
 Vol. 7, nos. 2 and 3, a fair supply
 Vol. 7, no. 4, low

We must note that the price listed here may have to be raised. Repeated increases in postal rates have been absorbed by SITU so far, and we want very much to hold to our current prices, but we may be forced to pass on some of this increase to our members. We therefor suggest that if you want back issues, you order them now. Also, once an issue is out of print, it can only be obtained on special order (and a much higher price) as a photocopy.

Frank B. Salisbury. The Utah UFO Display: A Biologist's Report. Old Greenwich, Conn.: The Devin-Adair Company. 1974. \$7.95.

Dr. Salisbury's book is valuable on two counts, one primarily of interest to UFO 'buffs' and the other to the general reader. So far as I know it is the only detailed account of the rather remarkable series of sightings in the Uintah (you-in'taw) Basin of Utah. Eighty of these are enumerated in an appendix, with narrative accounts comprising the first half of the book. The reliability of the various witnesses is gone into rather thoroughly also.

The second half is devoted to an overall analysis of ufology and contains a number of reports, some 'standard' but others not generally known in this country. My only real complaint here is that someone has chosen to use the, perhaps technically more correct but awkward, term UFOology.

There are a number of appendices, some of astronomical events for comparison with the Uintah sightings, one on the UFO Wave of 1973, and a splendid annotated bibliography (of particular value to those new to ufology). There are illustrations and an index.

Lastly, Dr. Salisbury discusses Marjorie Fish's star 'map' (that goes a very long way toward confirming Betty Hill's story) and indicates his support of her findings both directly and indirectly; he invariably 'identifies' his hypothetical space people as coming from the Zeta Reticuli star system.

Douglas Dean and John Mihalasky and Sheila Ostrander and Lynn Schroeder. Executive ESP. Englewood Cliffs, New Jersey: Prentice-Hall, Inc. 1974. \$7.95.

This is a most interesting and important book that covers rather more than its title suggests; the 'subtitle' on the jacket is "the proven links between 'hunches' and success—and how businessmen employ ESP on a practical basis". The basic studies reported primarily concern the testing of businessmen to see whether the successful ones do have above average paranormal abilities (they do), and whether they deliberately and/or regularly use 'hunches', 'intuition', or the like to make business decisions. However, these studies stem from something of much greater basic importance.

In 1962 Messrs. Dean and Mihalasky began tests with physiological instrumentation which demonstrated objectively that their test subjects underwent an unconscious change in fingertip blood volume when names of persons they knew were 'sent' to them by someone in a separate room. This is very different from ESP-card testing and other methods usually used, and is virtually foolproof. Even if a person has learned to control certain bodily functions, including the blood volume in his fingers, he still would have to 'guess' just when the proper signal was being sent and the chances of his achieving the results shown here are not good. In fact, this is so improbable that it can almost be ruled out a priori.

The later experiments pitted executives against a computer in picking six-digit numbers. Here the results were far more complicated, and I shall not attempt to summarize them here. However, the executives were divided into two major groups based on their concept of time, and the results of the two groups are consistently different. The technical details are included in extensive appendices, as are those of the physiological studies. Of considerable interest are the studies that indicate some of the factors that either enhance or diminish precognitive ability, and here the book becomes of practical use not only in

business but in other fields in which groups of persons are asked to plan for the future. And the authors do make concrete suggestions rather than vague generalizations.

The book is anecdotal in part, but no excessive claims are made for the stories used to illustrate the use of 'ESP' by executives.

In all it is a very worthwhile book. It also contains an extensive bibliography and references, an index, and a few illustrations.

Jacques Bergier and the Editors of INFO (Ronald J. and Paul J. Willis). Extraterrestrial Intervention: The Evidence. Chicago, Illinois: Henry Regnery Company. 1974. \$7.95.

I am sorry to have to be rather rough on this book, but in the first place the title is totally misleading and an obvious attempt to climb on the von Däniken bandwagon, and secondly it will be of little interest to those who receive the INFO Journal since most of the material is reprinted from that publication. Some of the articles are of fair length, but a number of short newspaper clippings are also printed here, without comment of any kind. It is divided into four parts: "Vanished Civilizations", "Extraterrestrial Beings Among Us", "Strange Creatures", and "Fortean Phenomena". It is a slim volume with rather large type—164 pages, and no index. If you want it, wait for the paperback; it is not worth \$7.95.

There is one item in this book that I really would like to have explained. In a newspaper report of a poltergeist it is stated that "...the lad became a catalyst for strange furniture movements. Beds balanced on three legs,..." I know we are fond of saying that nothing is impossible but I believe this is an exception.

Kurt Mendelssohn, The Riddle of the Pyramids, New York: Praeger. 1974.

The author calls The Riddle of the Pyramids a book about a scientific discovery — the reason for the pyramids — in the explaining of which he will no doubt distress dilettante Egyptologists within our ranks who subscribe to the more exotic explanations for the building of these monuments to a technological competence they cannot conceive of as being indigenous in origin. Pyramidologists have talked of the function of the pyramids as astronomical observatories, as refuges from the Flood (!), as repositories of divinely inspired prophecies, or of course as the work of visitors from another planet.

Advocates of this mythological approach to history will undoubtedly quarrel with Dr. Mendelssohn's contention that even the generally accepted theory that the large pyramids are nothing more than royal tombs may in fact be based upon what he gently suggests is a "subtle logical error. While it is readily admitted that the pyramids served as royal mausolea, it does not necessarily mean that this was the only purpose of their construction. In fact, it probably was not even the main purpose." (Metaphysically oriented readers will note that he does not refer to the probable use of some relatively isolated pyramids by the surviving Wisdom Schools in Ptolemaic times. Dr. Mendelssohn is concerned with the reason for the pyramids, and only peripherally with what happened to them in subsequent millennia.)

His approach to history will likewise distress the romanticists, who tend to forget that Egyptian society was matrilineal, which means that inheritance, including that of the throne, always went through the female line. (He quotes the plea of Tutankhamun's widow, Ankhsenamun, daughter of Akhnaton and Nefertiti, to the King of the Hittites. "My husband is dead and I have no son. Send me one of your sons and he will be my husband and lord of the land of Egypt.") Similarly his description of what were the Egyptian peoples, is rational and logical, as is his description of Imhotep, known in his time as "Chancellor of the King of Lower Egypt, First after the King of Upper Egypt, Administrator of the great Palace, Hereditary Nobleman, High Priest of Helipolis, Builder, Sculptor and Maker of Vases in Chief."

Imhotep set out originally to build at the desert edge above Memphis a magnificent monument for the living god, the Horus Neterkhet Zozer. In the course of doing so, coping with the problems presented by this large-scale organization needed for implementing his plans, made necessary what was to become an efficient and complex civil service. For the first time in their history, tribal villagers were welded by common work into people with a consciousness of nationhood: it was probably for the first time — and remember this was five thousand years ago, when unity was still new to the two Egypts — that people thought of themselves first and foremost as Egyptians.

What resulted was a multi-racial society, a cultured and dignified world, a society which cherished the old virtues. Greed and corruption are described as the worst malady, so incurable and so contagious that any dealings with it are impossible. A man must not boast of his learning, but should always be ready to learn himself, if necessary from the poor and the humble. And do not approach the women in your friend's house: "Men are made fools by their gleaming limbs and brief enjoyment soon turns into bitter regret."

This was the social and intellectual background against which the hundred year long Pyramid projects must be seen. This is a sober and essentially practical society whose reactions were eminently practical. There were therefore political and economic reasons for building the pyramids; the aim was in effect the creation of a new society. There is no doubt that Dr. Mendelssohn is right in describing the pyramids as "the place where man invented the state."

THE SOCIETY FOR THE INVESTIGATION OF THE UNEXPLAINED

GOVERNING BOARD

Trustee (and President)
Trustee (and Vice-President)
Trustee (and Secretary)
Trustee (and Treasurer)
Trustee
Trustee
Trustee
Trustee
Trustee

Hans Stefan Santesson
Robert C. Warth
Sabina W. Sanderson
Adolph L. Heuer, Jr.
R. Martin Wolf
Robert J. Durant
Robert E. Jones
Albena E. Zwerver
Walter J. McGraw

EXECUTIVE BOARD

Administrative Director
Executive Secretary
Technical Consultant
Research Consultant
Mass Media

Robert C. Warth
Albena E. Zwerver
Robert J. Durant
Carl J. Pabst
Walter J. McGraw

EDITORIAL BOARD

Editor and Publisher
Executive Editor
Managing Editor
Consulting Editor

Hans Stefan Santesson
Sabina W. Sanderson
Robert J. Durant
Walter J. McGraw

SCIENTIFIC ADVISORY BOARD

- Dr. George A. Agogino – Chairman, Department of Anthropology, and Director, Paleo-Indian Institute, Eastern New Mexico University. (Archaeology)
- Dr. N. Burtshak-Abramovitch – Academician, Georgian Academy of Science, Palaeobiological Institute; University of Tblisi. (Palaeontology)
- Dr. Carl H. Delacato – Associate Director, Institutes for the Achievement of Human Potential, Philadelphia, (Mentality)
- Dr. W. C. Osman Hill – Dublin and London (Comparative Anatomy)
- Dr. J. Allen Hynek – Director, Lindheimer Astronomical Research Center, Northwestern University. (Astronomy)
- Dr. George C. Kennedy – Professor of Geology, Institute of Geophysics, U.C.L.A. (Geomorphology and Geophysics)
- Dr. Martin Kruskal – Program in Applied Mathematics, Princeton University. (Mathematics)
- Dr. Samuel B. McDowell – Professor of Biology, Rutgers University, Newark, N. J. (General Biology)
- Dr. Vladimir Markotic – Professor of Anthropology, Department of Archaeology, University of Alberta, Canada (Ethnosociology and Ethnology)
- Dr. Kirtley F. Mather – Professor of Geology, Emeritus, Harvard University. (Geology)
- Dr. John R. Napier – Unit of Primate Biology, Queen Elizabeth College, University of London. (Physical Anthropology)
- Dr. W. Ted Roth – Assistant Director, Baltimore Zoo, Baltimore, Maryland. (Ecologist & Zoogeographer)
- Dr. Frank B. Salisbury – Head, Plant Science Department, College of Agriculture, Utah State University. (Phytochemistry)
- Dr. Berthold Eric Schwarz – Consultant (Brain-Wave Laboratory), Essex County Medical Center, Cedar Grove, New Jersey. (Mental Sciences)
- Dr. Roger W. Wescott – Professor and Chairman, Department of Anthropology, Drew University, Madison, New Jersey. (Cultural Anthropology and Linguistics)
- Dr. A. Joseph Wraight – Chief Geographer, U. S. Coast & Geodetic Survey. (Geography and Oceanography)
- Dr. Robert K. Zuck – Professor and Chairman, Department of Botany, Drew University, Madison, New Jersey. (Botany)

