



PURSUIT

"SCIENCE IS THE PURSUIT OF THE UNEXPLAINED"

VOL. 5, NO. 1

JANUARY, 1972

SOCIETY FOR THE INVESTIGATION OF THE UNEXPLAINED

Columbia, New Jersey 07832

Telephone: Area Code 201 496-4366

ORGANIZATION

The legal and financial affairs of the Society are managed by a Board of Trustees, in accordance with the laws of the State of New Jersey. These Officers are five in number: a President, elected for five years; two Vice-Presidents; a Treasurer; and a Secretary. General policy is supervised by a Governing Board, consisting of the five Trustees, and four other members elected for one year terms. General administration and management is handled by an Executive Board, listed on the inside back cover of this publication. The Editorial Board is listed on the masthead of this journal. Finally, our Society is counselled by a number of prominent scientists, as also listed on the inside back cover of this journal. These are designated as our Scientific Advisory Board.

PARTICIPATION

Participation in the activities of the Society is solicited. Memberships run from the 1st of January to the 31st of December; but those joining after the 1st of October are granted the final quarter of that year gratis. The annual subscription is U.S. \$10, which includes four issues of the Journal PURSUIT for the year, as well as access to the Society's library and files, through correspondence or on visitation. The annual subscription rate for the journal PURSUIT (alone, and without membership benefits) is \$5, including postage. (PURSUIT is also distributed, on a reciprocal basis, to other societies and institutions.) The Society contracts-- with individuals, and institutional and official organizations for specific projects -- as a consultative body. Terms are negotiated in each case in advance. Fellowship in the Society is bestowed (only by unanimous vote of the Trustees) on those who are adjudged to have made an outstanding contribution to the aims of the Society.

NOTICES

In view of the increase in resident staff and the non-completion, as yet, of additional living quarters, there is no longer over-night accommodation for visitors. Members are welcome to visit to consult our files, but we ask that they make application at least a week in advance to prevent 'pile-ups' of members who, as a result of the simple lack of facilities, as of now, cannot be properly accommodated.

The Society is unable to offer or render any services whatsoever to non-members. Further, the Society does not hold or express any corporate views, and any opinions expressed by any members in its publications are those of the authors alone. No opinions expressed or statements made by any members by word of mouth or in print may be construed as those of the Society.

There have been a number of articles recently on the problem of junk mail and the way in which one's name gets on such a mailing list. We should like to assure our members and subscribers that our mailing list is available only to resident staff at our headquarters.

PUBLICATIONS

The Society publishes a quarterly journal entitled PURSUIT. This is both a diary of current events and a commentary and critique of reports on these. It also distributes an annual report on Society affairs to members. The Society further issues Occasional Papers on certain projects, and Special Reports on the request of Fellows only.

RECORD: From its establishment in July, 1965, until the end of March 1968, the Society issued only a newsletter, on an irregular basis. The last two publications of that were, however, entitled PURSUIT-- Vol. 1, No. 3 and No. 4, dated June and September, 1968. Beginning with Vol. 2, No. 1, PURSUIT has been issued on a regular quarterly basis: dated January, April, July, and October. Back issues, some available only as Xerox copies, are available; those wishing to acquire any or all of these should request an order form.

Vol. 5, No. 1
January, 1972

PURSUIT

THE JOURNAL OF THE SOCIETY FOR THE
INVESTIGATION OF THE UNEXPLAINED

DEVOTED TO THE INVESTIGATION OF "THINGS"
THAT ARE CUSTOMARILY DISCOUNTED

Editor & Publisher: Hans Stefan Santesson
Executive Editor: Marion L. Fawcett
Managing Editor: Allen V. Noe
Associate Editor: Walter J. McGraw
Consulting Editor: Ivan T. Sanderson

CONTENTS

<u>The Taxonomy of Knowledge</u>	2
<u>Editorial: The Noemasphere</u>	3
<u>Ufology:</u>	
ADC and UFO, by William B. Stoecker	4
<u>Chaos and Confusion</u>	
The Ringing Rocks: Another Aspect	6
<u>Physics</u>	
Fire Walking, by Robert J. Durant	8
<u>Astronomy</u>	
A Tenth Planet -Or an Eleventh?	9
Water on the Moon	9
<u>Biology</u>	
The Hominidae and the Troglodytidae, by B. F. Porshnev	10
That New Zealand Sea Monster	11
On Evolution, by Ivan T. Sanderson	11
Black Pumas	12
The "What's-It" from South Dakota	13
<u>Anthropology</u>	
Light Wheels and Holograms That Use Acoustical Radiation, by Robert J. Durant	13
Cultural Expansion: Which Way?	16
Food for Thought	18
<u>Department of Loose Ends</u>	19
<u>Current Pursuits</u>	19
<u>Members' Forum</u>	20
<u>Book Reviews</u>	20
<u>Alma V. Sanderson</u>	24

THE TAXONOMY OF KNOWLEDGE

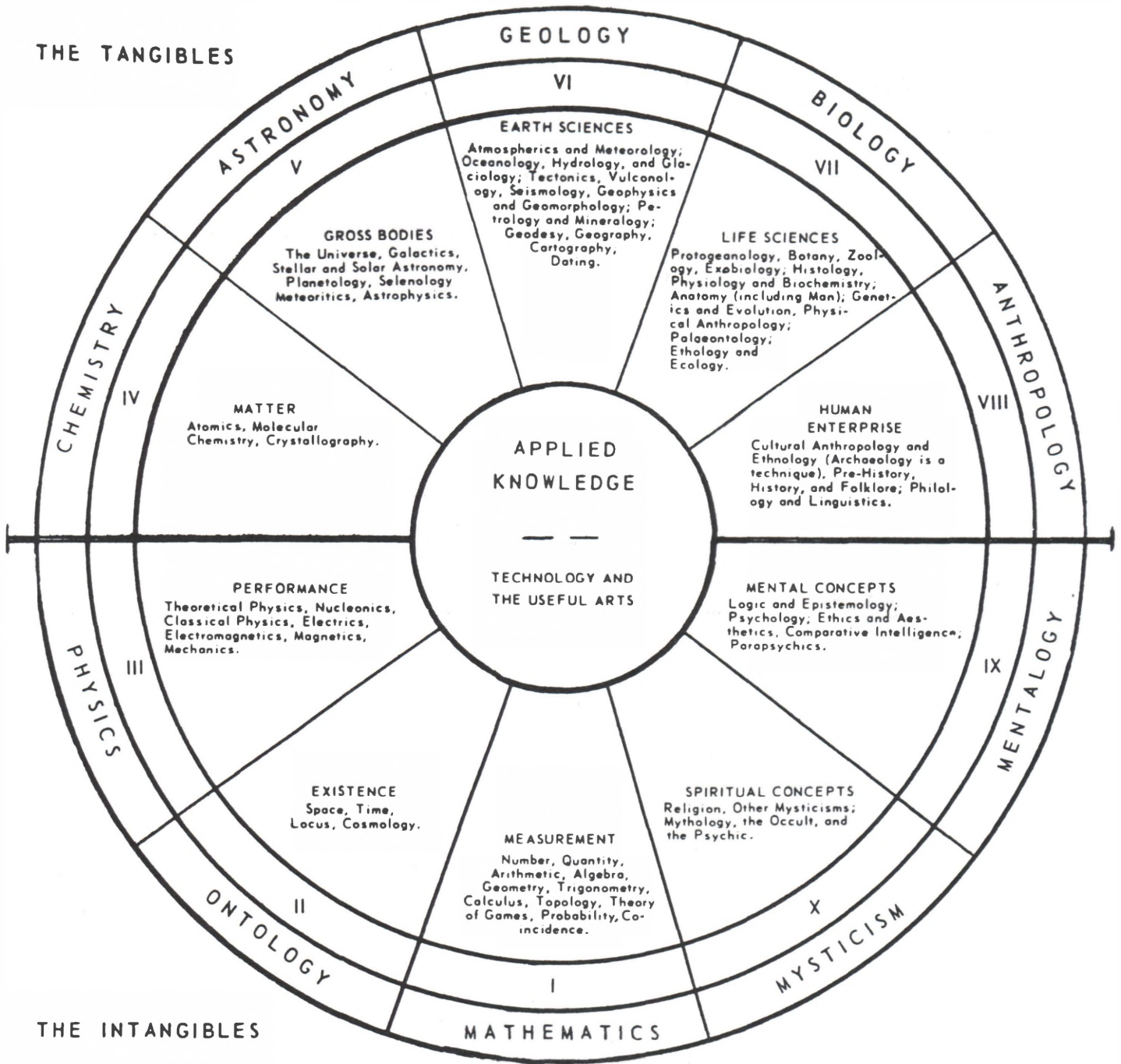

Everything in existence, including "existence" itself, and thus all of our possible concepts and all knowledge that we possess or will ever possess, is contained within this wheel. Technologies and the useful arts lie within the inner circle, having access to any or all of the ten major departments of organized knowledge.

From the KORAN: "Acquire knowledge. It enables its possessor to know right from wrong; it lights the way to heaven; it is our friend in the desert, our society in solitude; our companion when friendless; it guides us to happiness; it sustains us in misery; it is an ornament among friends, and an armour against enemies." - The Prophet.

EDITORIAL

THE NOEMASPHERE

Funny, but one has to go to Haile Selassie I University, in Addis-Ababa, Ethiopia, to get the first truly clear statement on reality. In a paper published by one R. O. Whipple at that seat of higher learning, reprinted in a publication named Not Man Apart*, we read with the utmost delight:—

“Organisms survive in the long run in proportion to the accuracy and completeness with which their internal information on how to meet the environment corresponds to the actualities of that environment. In human terms, our adaptation to our surroundings has become largely a matter of culture and its evolution, culture being a much more rapidly accumulating modifiable device than the chemical memories of our genetic heritage. Culture may be visualized as a composite of belief (what is) and technique (how to work with and use what is). The sum of beliefs held—the idea-environment, or noemasphere— is thus a major controlling factor in the day-to-day and year-to-year actions of mankind. The central and most essential environmental problem facing the species today is the pollution of belief by error, inadvertent self-deception, simple ignorance, and the intentional deceptions of advertising and propaganda.

“Just as organisms with faulty genetic memories become extinct, man will certainly eventually fail as a species in so far as the beliefs on which his actions are based are untrue. Therefore, correct uncontaminated knowledge and information are essential to human survival. The integrity of our idea-environment thus becomes a prerequisite for species continuity, let alone genuine progress. When that environment becomes increasingly polluted with the garbage of inadvertent error and the poisons of intentional lies and distortions, our potential for maintaining or improving the quality of life is proportionately reduced. Whatever else may be required for the future, our insistence upon adherence to truth in every form of communication must be uncompromising.”

The word noemasphere is derived from the Greek word noema that meant “understanding”, and this appeared in the title to Mr. Whipple’s article. What better word? Our basic trouble today is not either a lack of information — to the contrary; we have an overabundance of same— nor in communication, though there are damned few people who can do just that even if they speak the same language; but, in true understanding. Talk about garbage! Try reading the New York Times or the Congressional Record. Try ploughing through a pile of scientific and technical journals every week as we do; or the so-called ‘popular science’ publications. Quite apart from the typos, it is becoming every day increasingly impossible to figure out just what they are trying to talk about. And when it comes to television. . . . but words fail us.

The almost universal mendacity today —and all the way from international politics to phrenology— is completely terrifying. We have almost given up debate any more because we find that people —and even when discussing their own speciality— often talk more unutterable rubbish than even those who don’t know anything of that speciality. Worse, nobody seems to absorb what they read —if they do so— any more, but continuously argue about the findings of their peers. Better go to an African tribesman —if you can find one any more— if you want to have an intelligent philosophical discussion over a bowl of palm wine. And, anent this, try attending a symposium of any kind today.

No wonder our younger generation is ‘protesting’, and the public generally is becoming disenchanted with science and technology in particular. The former are taught out-of-date rubbish, and the latter are fed outright lies; and we strongly suspect that this goes for many other if not all fields of information. We wish to be as impolite as possible. What, so help us, are things like “relevance”, “environmentalism”, “ESP”, and even this “ecology” bit? Relevant to what? Which environment? What’s extra about the sensory perceptions of humans and other animals (plants, one might add)? What about the sensory reception? And what, for pity’s sake, do these yakkers really think they mean by ecology?

The so-called science of Ecology —meaning the study of ‘houses’ or natural niches— was initiated by one Professor Charles Elton at Oxford University in England in the late 1920s. It was probably best, and most succinctly, stated by Professor Henry J. Oosting of Duke University some years ago as being; “The study of organisms, their environment, and all the inter-relationships between the two”. So why can’t we apply it just this way; and find a new word for “pollution” that is really “relevant” to the issue on hand?

Only a little more mendacity and none of us will know what to believe; and we’ll extinguish ourselves. That TV performer, Jack Webb, ought to run everything; starting with, and adhering to, his basic admonition: “I want the facts, Ma’am; the facts”. Shades of old Charles Fort!

Ivan T. Sanderson.

*Published for Friends of the Earth (the John Muir Institute of Environmental Studies) and the League of Conservation Voters, Washington, D.C.

UFOLOGY

ADC and UFO

by William B. Stoecker

In 1965 I entered the Air Force's Air Defense Command (ADC) as a second lieutenant, and in August of 1966 I was assigned as Assistant Chief of the Intelligence Division at 29th Air Division Headquarters in Duluth, Minnesota. Prior to 1966, UFO investigation was an intelligence function, governed by Air Force Regulation 200-2; that year, AFR 200-2 was superseded by AFR 80-17, making UFO investigation a research and development responsibility. AFR 80-17 allowed each base commander to assign to any officer he chose the additional duty of UFO investigation. The assigned officer would investigate UFO reports and send teletype messages to the Foreign Technology Division at Wright-Patterson AFB, Ohio, then headed by Major (later Lieutenant Colonel) Hector Quintanilla. After the Condon project at the University of Colorado began, UFO Investigation Officers were also required to mail a copy of each report to Colorado.

In our case, the Division Commander (not the Base Commander) verbally authorized the Intelligence Division to continue investigating UFOs — so little, if anything, was changed for us by the new regulation. I can only say that my years in the Air Force were the most disillusioning in my entire life up to that time. UFO investigation by the military establishment was a farce.

The years that followed included a number of radar sightings. Since most people have only a hazy idea of how radar works, a brief explanation is in order. A radar is like a rotating searchlight sending out a beam, not of light, but of short wave radio pulses. It indicates the direction and the distance to any object detected; it does not indicate size or shape. A search radar (the big, rotating "spotlight" type) cannot measure altitude: this is the function of other, manually controlled radars called height finders. These can be turned in any direction, and rocked up and down.

It is easy to see how a UFO might escape detection. If it is flying above the beam, say twenty or thirty miles up, it will not be detected. If it flies below the beam, say a few hundred feet or less above the ground, it will not be detected. If the beam is pointing north when the UFO flies in from the south, it will not be detected. A vehicle capable of flying at any altitude and almost any speed could evade the beam altogether. More importantly, if the beam detected the UFO once at one position, and ten or twelve seconds later detected the same UFO thirty or forty miles away, most radar operators would not correlate, or connect, the two "paints", or "blips". The operator would probably assume that they were caused by a "bug" in the system, or that they were "angels", or cases of "anomalous propagation" — that is, atmospheric dis-

turbances. Add to this the reported ability of the UFOs to make sharp turns at high speeds, to climb and descend vertically, and to hover, and it is easy to see why radar sightings are fairly rare.

In ADC, most of the search radars are tied into a computerized system called SAGE (Semi Automatic Ground Environment). At each air division headquarters there is a large blockhouse called the Director Center, or DC. Here, the radar inputs, having been through a computer, reappear on consoles having only a superficial resemblance to ordinary radar screens. The important thing here is simply this: the computers automatically eliminate most of the unwanted "angels". Our air defense system is designed to detect, track, and destroy conventional aircraft — not fast moving, highly maneuverable space craft.

One possible radar sighting, which happened in the fall of 1967, clearly shows the Air Force's incompetence. A RAPCON (Radar Approach Control) radar at Kincheloe AFB, Michigan, detected several objects moving 2000 miles per hour. Now, the RAPCON is designed for tracking aircraft near landing, when distances and time intervals are short, and it may therefore have a "sweep" as fast as five or six seconds. That is, the radar "searchlight" makes a complete, 360 degree sweep of the sky every five or six seconds (the long range search radars have a ten or twelve second sweep). This, incidentally, also makes the RAPCON ideal for detecting and tracking UFOs moving at high speeds.

The investigation officer at Kincheloe sent in a report, but then the people at the Colorado project asked me to do a follow-up investigation, to see if any of the search radars within range of Kincheloe also detected the objects. If only one radar detected them, it could be AP* or a bug in the system; if two or more radars tracked them, we could be fairly sure something was out there. I checked with the people at the DC where I worked, but no one had any record of the incident. This seemed rather strange; one would expect such an unusual sighting to be immediately reported to the DC. I called the radar sites, and received no cooperation whatever — no one knew anything, and no one had any record of anything. I noted this in my brief report to Colorado.

Colorado then sent two field investigators — Dr. Norman Levine and Mr. John Ahrens — to investigate. They went first to Kincheloe and then came to Duluth. I was highly impressed by their obvious intelligence, sincerity, and open-mindedness, and began to hope that the Colorado project would actually perform a thorough and unbiased investigation. Little did I know that Dr. Levine would later be forced to resign. On this day, however, the two investigators wanted to search further at the DC for records of any possible

*I.e. anomalous propagation or "angels".

detection of the objects by other radars. They were given a longer and more painful version of the same run-around I had gone through earlier. The difference was that I had given up more easily; being in the Air Force myself, I knew what to expect.

While I was a UFO investigator I noticed certain patterns. For one thing, the radar sighting mentioned above was in northern Michigan, near Sault Ste. Marie, a town located near the locks where the Saint Lawrence Seaway passes from Lake Michigan to Lake Superior. I noticed that this area always generated a disproportionately large number of sightings, despite its relatively low population density. For example, the famous case (in the early 1950s—long before my time) involving the disappearance of an F-89 and its two crewmen originated in this area. I noticed that many of the UFOs in this area were initially seen coming from the north by northwest. Extending a line over a map in that direction, I noticed that the line passed through a vast and thinly settled area west of Hudson Bay. It was in this area (and near my imaginary line) that, according to the late Frank Edwards, an entire village of Eskimos vanished in 1930.* Probably a coincidence. Probably.

I also noticed that UFO reports in my own area were more common in the fall—perhaps due to the clear air—and that the overwhelming majority were seen at night. But still another pattern emerged. A UFO would often “hang around” an area for several days. If someone in Duluth saw one on Tuesday night, someone else would frequently see one on Wednesday night. Then there would be weeks or months of relative quiet, and then another brief wave of sightings. My question was: Where did they go in the daytime?

Look on a map. Draw a downward-sagging arc around the Saint Lawrence, the Great Lakes, and up

*Stranger Than Science. Also recounted (probably “borrowed” from Edwards) in other collections of this type.

Our member #621 has been doing some extensive checking on various happenings that keep cropping up in books on *fortean*, and he tells us that the historian of the Royal Canadian Mounted Police has labelled this story “completely fictional”. Where Frank Edwards, whose version is best known, got his information we do not know (it has proved impossible to lay hands on his original files) and it is possible—note the qualifying word—that the name of the village or other details may have gotten garbled somewhere along the way. Though Edwards calls his stories “fully documented” in his introductions, he never bothered to include the documentation, which makes his material exceedingly difficult to check.

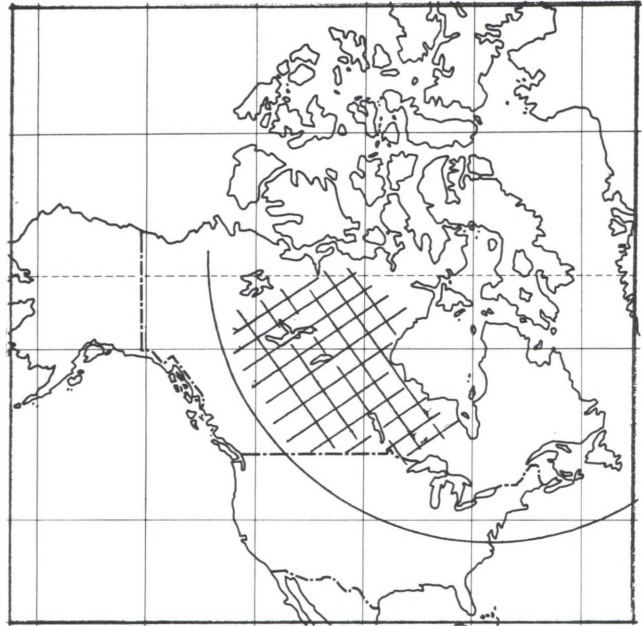

The cross-hatched area is littered with lakes.

around Great Bear Lake and Great Slave Lake in northern Canada. Within the arc is a vast region of innumerable lakes, ponds, and swamps of varying size and depth, and at its center is Hudson Bay. Northern Minnesota, Michigan, and Wisconsin are on the fringes of this area, and Duluth is at the tip of Lake Superior, a vast area of very deep water. Perhaps the UFOs spend their days submerged.

After the very active year of 1966 the number of UFO reports declined throughout 1967, and in 1968 our office received only a very few. One final incident of possible significance happened in the early spring of that year. Major General Jensen, then Vice Commander of ADC, visited our base while on a routine tour of ADC facilities. He asked to see the UFO Investigation Officer. I was surprised to say the least, for I had never heard of any officer above the rank of captain even mention the subject of UFOs, except to debunk them. I went to our Division Commander's office and there met General Jensen, who asked me what I thought of UFOs—I got the impression that he was sort of checking up on the investigators at each base. I cautiously replied that I thought UFOs, whatever they might be, should be carefully studied. He said that he had once been assigned to Project Blue book, and that he agreed with me, that we had better study UFOs now or we might regret it later.

After three years, I'm still wondering what he meant.

We apologize for the delay in getting out this issue of PURSUIT, but things have been a bit rough here. If things are pasted up crooked, it is because I (MLF) have, temporarily, to work with one eye—the other is suffering from a staphylococcal infection which I wouldn't wish on my “worst enemy”.

CHAOS AND CONFUSION

THE RINGING ROCKS: ANOTHER ASPECT

We place this under C&C on this occasion because we are not at all certain of the cause of the phenomena discussed below. Much has been made of the purely geological aspects of the Ringing Rock "fields", and they have been pronounced "explained" by a number of persons. Whether these last even know of some of the effects produced on some visitors to the rock fields, we do not know.

On the 14th October of last year our member #944 wrote as follows:

"I visited the Ringing Rocks (at Upper Black Eddy) for the first time, on Sunday, 3 October 1971, from 5:15 to 6:00–6:15 p.m., having driven there from Audubon, N.J. On site, I slipped, merely scraped one forearm. On driving back to Philadelphia, I noticed on leaving the site that I was very disoriented and confused as to direction—north and south were reversed in my thinking and I swore up and down that despite the road signs, we were headed in the 180° opposite direction. My companion had not gotten out of the car to visit the site and, thanks to her lack of symptoms and proper orientation, we got back without incident. Disorientation lasted from 6:15 to about 8:00 p.m., with confusion slowly lessening about 7:40 or so, and suddenly disappearing at 8–8:10. I was in the best of health, an experienced driver, (as always) sober and unmedicated. There had been no symptoms before arriving on site, of any kind, and no previous experiences like this one ever. It has not recurred. I plan to go back to the Rocks soon—with a friend to stay in the car."

On the 19th of October, he wrote:

"I repeated my journey this past Sunday, 17 October 1971, taking the same route there. Arrival at the site was at 4:45 p.m. I stayed on the site, climbing all over the rocks much like a monkey, until 6:30 p.m. I then drove to Milford, NJ, and drove about for ½ hour, till 7:00 p.m., without noticing anything unusual. On returning toward Philadelphia at 7:15 p.m., I suddenly began to feel the same disorientation of directional sense with 180° reversal of north-south orientation. At the time I was about 5 miles north of Upper Black Eddy, just having entered Route 611 South. My companion had not visited the rocks themselves and felt nothing (and was quite dubious about my dizziness). I followed the signs back toward Doylestown. Not till I reached Doylestown did the disorientation and dizziness cease. It was, though, milder somewhat than the previous episode. Next, I plan to drive up there again, but not go out on the rocks themselves, and merely take the same route back, to see if anything happens."

November 9, 1971:

"I've made one final trip there, almost exactly reproducing all the particulars of the previous two trips with the important exception of not walking out into the rocks themselves but merely spending time walking about in the nearby road and woods. Result—no unusual effects or disorientation at all on the return trip. Naturally, this was not intended as a controlled scientific experiment."

On the 16th November, #944 visited our HQ and we had a chance to look him over (and he us, of course). He is an eminently "solid citizen" and has medical training. Our discussion apparently changed his mind about that "one final trip" since we received the following, dated the 21st November:

"Re: Ringing Rocks (once again). Today I took my immediate family on an unannounced outing to Ringing Rocks, the party comprising myself, mother, father, and maiden aunt (mother's sister). None of them knew that I was ever there before, nor did any know of the miserable effects upon me of the place after each visit. On reaching the site, quite on a lark it was made to seem, the following things happened:—

"Mother began to shiver and shake, demanded to go back to the car, for she suddenly felt terribly cold. She felt that the place 'had something wrong (!!) with it' and that it was full of the portent of something terrifying and possibly injurious. She is normally an exceptionally rational and lucid person, not given to fearful behavior. She said that the place gave her the creeps and that she felt frightened.

"On the way back my aunt complained of severe dizziness and some nausea (shades of me!!).

"My dad, a cardiac patient for some 8 years, began to complain of palpitations and irregular pulses. He was fascinated by the geological wonder of the site, and repelled by the foreboding he felt there. He said that it felt to him 'as if time were wrong there, or some sort of radiations were hitting us', or that gravity and time were sort of 'wrong'.

"Note— The comments were elicited separately, out of earshot one from another!! My mother was actually scared silly by the place, but she is a survivor of several unspeakable horrors of war in Europe and is normally as strong as steel. Nothing whatever ever disturbs her equilibrium.

"I questioned each person separately, and none was privy to the comments of the others. In addition, my father said that he'd never let me fly a plane over the place (!). They all heartily loathed the site and made me swear never to go back, such was their foreboding and disturbance. My dad, an intelligent and accomplished gentleman, lost track of the approximate time of day on the way back, thinking it to be much later, and was thoroughly confused as to direction and place. Frankly, I felt fine—just scared as hell and yet fascinated. My aunt's nausea and dizziness began on leaving the site!! However, about 1 hour

after leaving the site, I began to have dizziness of a mild to moderate degree and had to fight hard to keep track of orientation and direction. Next stop — Devil's Run!"

He hasn't been heard from since (as of the time of writing this, at least!).

This business of directional disorientation has come up before, and seems to be intermittent —as do the other 'symptoms' recorded above. On one occasion, a visit by the full committee on the R.R., we had two compasses with us, one a professional surveyor's compass, the other an inexpensive wrist compass; each 'misbehaved' once during the course of our visit, the compass needle suddenly swinging a full 180° and then back again. There was also a rather violent argument as to which way was north, some of those present insisting that north was "over there", and continuing to so insist even when it was pointed out that it could not be since the sun was 'thataway.' Also of interest is the statement by 944's father that he would not want him to fly over the area. First of all, we have had the most incredible difficulty in getting anyone to take proper aerial photographs of the site; and secondly, there is something odd which appeared on aeronautical charts in 1970. We obtained several such charts when investigating the Caldwell "sky-lines" and noted nothing "remarkable" on the 1969 chart, but. . . At approximately the location of the Upper Black Eddy Ringing Rocks site on the 1970 chart there appears the single word "Caution". Why? There is a power plant marked some distance north on the east side of the Delaware River, but there is a power plant at Portland, Pa., also —and no "Caution".

I (MLF) have visited the site several times and have not experienced any of the 'difficulties' reported by #944, though a rather large number of persons have done so, reporting either in person or by letter. And

these effects are not limited to the Upper Black Eddy site. Member #230, visiting the site at Pottstown, became so dizzy and disorientated that she had to be almost literally carried to the car. Though she was apprehensive when we visited the U.B.E. site, she admitted that her very slight symptoms there were probably 90% "psychological" and a carry-over from her bad experience at Pottstown. The appearance of the site in summer is somewhat startling, green trees surrounding a vast mound of pink rocks, but is not, on the face of it, depressing; nor is the mere physical difficulty of clambering about on the rocks —some of which tilt under one as well as ringing— enough to explain the uncanny effects produced on occasion. Radiation gauges, such as are worn by laboratory personnel, have been left on the site for weeks without showing any abnormal radiation. On the other hand, there is something 'funny' about the light there: camera-men have had inexplicable difficulties, and light meters have gone 'wild' for no apparent reason; and our director, Ivan T. Sanderson, had some very peculiar difficulties with a balscope, even to "seeing around corners" as it were!

We would like a nice, neat explanation of all this, but the fact is, the ringing rocks are not explained. New experiments —particularly those having to do with so-called infrasonics (which might explain the "psychological" problems) —are being planned, as are some dealing with the effect of "light", all the way from the ultraviolet through the visible spectrum to the infrared.

We hope that this rather lugubrious report will not deter members from going to visit the Ringing Rocks. The more data we can obtain, the better —and the more likely we are to find an answer. We also are in the process of obtaining competent archaeological help for what member #229 calls "The Corner Store", an underground chamber made of morticed stones.

More Classic Correspondence

Recently we received a note, as follows: "Dear Sirs, I am an 8th grader in Western Junior High School in Byram Conn. I am doing a report on scientific happenings I would like it very much if you would send me any information you could spare on this subject Sincerely (name deleted)." This is what they call an education?

Another classic received recently contains the following questions concerning Ivan Sanderson's Invisible Residents and the Bermuda Triangle: "In your opening lines you say, '. . .with due apologies to the memory of the Bard. . .The Much Vexed Bermoothes.'. What is meant by this? Has the famous under sea explorer Jacques Costuea (sic) ever investigated this aquatic mystery?" Words fail us. What do "they" teach our children. If anything.

The Hazzards of Publishing

From the letters column of The New Scientist, 30th September, 1971, "Sir: I've heard of wild birds being fitted with rings, but to provide swans with signets (your Monitor, 23rd Sept., p. 669) is surely going too far! (signed) B. J. Hazzard, 8 Tilbury Road, Tooting Common, London S.W. 17."

III. PHYSICS

FIRE WALKING

by Robert J. Durant

One occasionally reads of "fire walking" ceremonies in which individuals are said to walk on glowing coals without any apparent injury. The usual procedure is to dig a pit several feet deep and 15 or 20 feet long. The pit is filled with hardwood logs which are set ablaze. Some hours later when the logs have been reduced to embers the pit is ready for the fire-walking demonstration.

(In other cases, the pit is lined with stones, brush is piled on and burned until the stones are white hot, and then the whole is swept clear of ashes. Editor.)

These affairs are invariably imbued with religious significance by the practitioners. They take care to explain that "faith" is the prime requisite for a successful traverse of the fire. This explanation has been taken seriously by some fairly sceptical reporters simply because the holy men, and at times a few particularly enthusiastic members of the audience, really do walk on the extremely hot coals. Nor do they make a quick hop, skip and jump through the fire. These fellows take a deliberate walk of up to a dozen steps though the average seems to be three to five steps. The fire walkers don't linger, but they don't run either.

The obvious 'explanation' that the walkers have prepared the soles of their feet with some sort of insulating material has been dealt with by fastidious examinations made before and after the walks. The temperature of the surface of the pit has also been confirmed to be every bit as hot as it ought to be. And no report of a fire-walking demonstration is complete without the description of pieces of paper and cloth instantly bursting into flame when dropped into the pit.

In short, the fire-walking act is absolutely genuine. Unfortunately, for many this has meant that they have been witness to a miracle of sorts, or, if that is too strong a term, to a suspension of the laws of nature. The devotees of the "Strange and Unknown" cite fire-walking as irrefutable proof of life-after-death, mind-over-matter, and what-have-you. In fact, fire-walking

is accomplished by 99% perspiration and 1% inspiration (with apologies to Thomas Edison). The very heat that has convinced sceptics that fire-walking is paranormal in nature is the secret of the process. The heat causes the soles of the feet to sweat, and a perfectly natural, though little known, process called the Liedenfrost effect does the rest.

To illustrate the Liedenfrost Effect, let us imagine a droplet of water on a hot surface such as a frying pan. The pan must be slightly concave to prevent movement of the droplet. If the temperature of the pan is raised from room temperature to just below 100° centigrade (212° F.), the drop remains in its normal state and shape. When the pan reaches a temperature slightly in excess of 100° the drop begins to evaporate at once. But if the pan is heated considerably more, on the order of 400–500° C., the drop of water will not evaporate instantly as before. Instead, it will remain in place and retain its shape for a period of three to four minutes. A thin but quite effective insulating layer of water vapor is formed between the droplet and the very hot surface of the pan.

Just don't try fire-walking on a 'cool' fire. You'll get burned.

Editor's Notes: One fact which should be emphasized is that the fire-walkers make darned sure that the coals are white hot and that there is not even a trace of ash on top of the coals since this would lower the effective temperature just enough to allow burns.

This same Liedenfrost effect is used by plumbers who seal leaks with hot lead, first spitting into the palm and then applying the boiling lead by hand, and is also used in certain areas of Africa in "trials by ordeal". If a crime has been committed, the suspects are lined up and an iron rod is heated until it is white hot. This is then drawn quickly across the tongue of each suspect in turn. In fact, the culprit usually bolts before the "judge" reaches him; he knows he is guilty and will be burned —this simply because he is nervous and his mouth becomes dry. The innocents, being sure of their innocence, have nice wet tongues, and the Liedenfrost Effect protects them from injury. It works every time.

Caption from a cartoon in Punch: "Why is it that everything I like doing, causes tumors in mice?"

Absolutely Monstrous

As reported by UPI, police in Wood River, Ill., received a call from a housewife stating that there was a "monster" in her yard. She described it as a "grayish-white substance, getting bigger and bigger. . . ." Police found a mass of bread yeast-rising in the heat of the sun.

V. ASTRONOMY

A TENTH PLANET? – OR AN ELEVENTH?

In our last issue we ran a short piece on the possibility that Leverrier's Vulcan, a small planet or planetoid, may indeed exist between Mercury and the Sun. An article dated the 18th November 1971 and credited to AP states that British and U.S. astronomers are testing a theory that there may be another planet in our solar system beyond Pluto. The scientists admit that this a dubious possibility and is based on minute irregularities in the motion of the planet Neptune. Nevertheless, they are ploughing through a mass of photographs to look for it, while admitting that the process will take a very long time.

If they do find it, it will be interesting to see what the astrologers make of it. The latter attribute all sorts of influences to Pluto which was not even suspected until about 1850 and not actually found until 1930. One wonders which planets controlled these aspects of human destiny before Pluto turned up.

WATER ON THE MOON

For years scientists have been making fairly flat statements about the Moon, often in direct contradiction of each other, but most have agreed all along that the Moon is an arid, moistureless body. They were even more certain of this after the Apollo 11 crew brought back some moon rocks. They received a rather severe jolt in March 1971, though the information seems to have been kept under wraps until October of last year and has, so far as we can tell, received very little publicity despite its profoundly interesting implications.

Instruments left on the Moon by the Apollo 11 crew and subsequent moon-walkers have detected water

clouds erupting like geysers through cracks on the the lunar surface. The cloud, consisting of 99% water vapour, covered an area of 10 or hundreds of square miles, depending on your source of information; and the eruption was accompanied by a number of minor moon quakes. The 'display' lasted about 14 hours.

Startled though the scientists may have been, there has reportedly been little disagreement that it was water vapour. What they have not agreed upon is where the water is located and in what form –and how much of it is there. One unidentified space scientist noted "If the interior of the moon is quite different from its exterior, where we know that all of the volatile materials have long since boiled off, it's possible that there is still some volatile matter trapped deep inside the moon. And it's finally working its way to the surface now. There haven't been any active volcanoes in the moon for at least the last 1 billion years, so if this actually proves to be water vapor from the depths, we may be seeing the last belches of the moon's vulcanism."

"Geysers" of this sort may explain many of the 'funny lights' reported on the moon (see the Chronological Catalog of Reported Lunar Events published by NASA); the "last belches" would seem to have been going on for quite some time. Even the suspicion of water in the moon makes the Luna City of the science-fiction writers a closer reality.

Or perhaps the "lunatics" are already there. We remember with amusement a cartoon that appeared just after the first successful Moon-walk: our rocket disappearing into the "sky" and a lot of little chaps with antennae popping out of the ground –the caption read simply "Are they gone?"

PURSUIT does not carry advertising, but we have been sent (via a circuitous route) a Slide-Chart Calendar which indicates directly the day of the week for a given date, i.e. the 31 December 1899 was a Sunday. (It works, too.) If you are interested, write to "Calendar", c/o SITU, and we will forward your request for more information.

A will probated in Maine read simply, "Being of sound mind and body, I spent it all."

If you have not yet paid your dues for 1972, where are they? \$10 per annum.

A Clarification:

All contributions and dues above the basic \$10 per year are deductible from Federal Income Tax. The basic \$10 is not deductible; i.e. a person paying \$100 for membership may deduct \$90 only.

VII. BIOLOGY

THE HOMINIDAE AND THE TROGLODYTIDAE*

The Antiquity of The Family Hominidae and Their Place in the Classification of the Higher Primates

by B. F. Porshnev

1. Haeckel and Vogt in 1866–1868 came forward with a hypothesis of the “missing link” between the ape and man which they called “ape-man”, or “man-ape”. Besides phylogenetic considerations they probably proceeded from Linnaeus who divided the genus *Homo* into two species, *Homo troglodytes* and *Homo sapiens*. This Haeckel-Vogt hypothesis was tacitly turned down by Darwin in 1871–1872. Dubois on the contrary tried to substantiate it, but the hybrid (sic) term, ape-man, caused among zoologists an idea alien to Haeckel and Vogt of this creature being a morphological mixture, whereas they (and Linnaeus) implied morphological affinity with man while such higher cerebral functions as speech and reason yet absent. The idea of ape-man (the troglodyte) was almost completely abandoned in the 20th century; hence it is implied that man descended directly from the apes without a connecting link. A number of circumstances, however, prompt us to revive that idea.

2. The main criterion for placing fossil forms in the family Hominidae is in practice the presence of accompanying stone implements. But such practice contradicts the purely morphological principle of classification. The creature first named *Prezinjaanthropus* and later – *Homo habilis* – made crude pebble tools but had the brain of the anthropoid† (V. I. Kochetkova). Nonetheless it is recognized that the discovery of the *Prezinjaanthropus* has put the antiquity of Hominids (“humans”) some 2 million years back. At the same time the contemporary and subsequent morphologically similar Australopithecinae are set apart as a subfamily for their tool making is considered doubtful or rudimentary. The geologically

*Professor Porshnev’s paper is reprinted here because of the considerable number of requests we have had for it.

For those who are not familiar with Professor Porshnev’s name and work, he is the director of one of the departments of the Institute of History of the USSR Academy of Sciences in Moscow, and virtually the doyen of ABSMery in the USSR: he has published extensively on the subject. Our copy of this paper is a typescript from Professor Porshnev; he does not indicate where it was published, but word of it seems to have spread through the ranks of those interested in ABSMery.

†I.e., an ape. Editor.

contemporary *Meganthropus* and *Gigantopithecus* are not included in the Hominidae at all because they undoubtedly made no tools.

3. The psychotechnical analysis of paleolithic implements shows that speech was not used in the process of their production which was sustained by automatic imitation within populations. The present level of neurophysiology and neuropsychology locates the function of speech and its control in the frontal, temporal and sincipital regions of the brain and in particular in those fields and zones which phylogenetically are developed only in *Homo sapiens* and are absent in full shape in all ancestral forms. This excludes the possibility of articulate speech during previous stages of evolution.

4. Hence, the advisability of abandoning the current wide nomenclature of fossil species included in the Hominidae. It is preferable to include in this family just one genus *Homo*, represented by a single species, *Homo sapiens* (sub-divided into *Homo sapiens fossilis* and *Homo sapiens recens*). The main diagnostic distinction of the Hominidae is the presence of such formations in the architectonic of the brain which made speech possible (and the correlative features in the organs of speech and in face). All the other bipedal higher Primates should be embraced by the family Troglodytidae (or Pithecanthropidae), no matter whether they made tools or not. Their main diagnostic distinction: bipedal locomotion (two-footed, erect, orthograde) with all the correlative features in the structure of the body, head, limbs and internal organs. This distinguishes them from the family Pongidae. The Troglodytidae (sive Pithecanthropidae) may be subdivided into the following genera: 1. *Australopithecus*, 2. *Meganthropus*, 3. *Pithecanthropus* (*Archanthropus*), 4. *Troglodytus* (*Palaeanthropus*) (subdivided into *T. fossilis* and *T. recens*). This fourth genus (commonly known as the Neanderthaler) can in its turn be divided into the following species: 1. Southern (Rhodesian type), 2. Classical (La Chapelle type), 3. Presapient (Steinheim-Ehringsdorf type), 4. Transitory (Palestine type).

5. The family Pongidae branched off the Primate tree in the Miocene. Currently it is represented by four genera: the gibbons (sometimes separated as a distinct family), the orang-utans, the gorillas and the chimpanzees. The family Troglodytidae departed from the anthropoid line in the Pliocene. At present it is represented by one genus, probably one species which can be described as “relic hominoid” (*Troglodytus recens*). From the Hominoid (Troglodytidae) line in the upper Pleistocene there separated a family of hominids in which the tendency towards the formation of species did not prevail and which from the very start and to the present level has been represented by the species *Homo sapiens*.

6. The taxonomic rank of a family for *Homo sapiens* is justified by the great biological significance of

such new formations as the organs and functions of speech, i.e. the second signal system. The unusually high tempo of this evolutionary progress (naturally, on the basis of useful variations of ancestral forms) indicates a mechanism of selection somewhat akin to artificial selection. The question is open now which species of the Paleanthropus (Troglodytus fossilis) was the direct ancestor of Homo sapiens fossilis. Perhaps we shall know this when the study of the relic Paleanthropus yields serial morphological material for there can be no doubt that the Troglodytus recens is a direct survival of the divergence of the Troglodytidae and the Hominidae.

THAT NEW ZEALAND SEA MONSTER

Reuters has announced that the organizers of a frog-jumping contest that is held in Christchurch, N.Z., has offered a \$10,000 reward for the capture of the "sea monster" that Japanese fisherman claimed to have seen off New Zealand, as reported in our October 1971 issue. Reuters notes "The monster was described as similar to a huge frog. . ." That wasn't the description we got (and we have been unable to learn anything further of the alleged tracks on the Lyttelton Peninsula).

In any event, two members have come up with possible explanations, to wit:

Member #164 suggests that it might well have been a dugong, one of the sirenians, and related to the Manatee that inhabits Florida. He points out that the nostrils, seen head on, might easily have been mistaken for eyes, and notes that the first person ever to see one (in a shark's gut) on Cook's expedition off eastern Australia, referred to it as a "hippo". The other suggestion comes from member #155 who nominates the Elephant Seal, which reaches 20 feet and might easily show five feet above the waterline. Males have a distinctive trunk, hence the name; but young males and cows do not. Neither has 6-inch eyes, but again, the eyes are large, and the nostrils might have been mistaken for eyes. We have no information on the artistic ability of the chap who drew the picture.

Unless they—or at least somebody—catches something extraordinary, I think we will drop this one. The frog bit would seem to be a publicity gag on the part of the frog-jumping contest organizers. The dugong is found in Australian waters and could have wandered over to New Zealand, though it is a bit

small if the size estimates given by the fishermen are accurate. The Elephant Seal is known to be extending its range, and its size would perhaps make it a better candidate. All this does not positively eliminate the possibility that the fishermen saw something new, but it reduces the odds considerably.

ON EVOLUTION

by Ivan T. Sanderson

The following quotation comes from The Nature of the Beast by T. Murray Smith, published by Jarrolds (London), in 1963, and will be found on page 133:

"The elephant or buffalo, seeking to escape, will go upwind. The rhino in a panic is just as likely to come blundering downwind; and an inexperienced hunter jumps to the conclusion that he is being charged and foolish Faru [local name for the Black Rhinoceros. Ed.] pays for the mistake with his life. If Darwin was right—which I do not believe—that only the fittest survive, it is a miracle that this prehistoric idiot exists, unless by fitness Darwin meant only physical fitness, which is absurd."

As one trained in the Darwinian concept of evolution, and more especially having spent the first half of my life observing and collecting animals for museums and zoos in the tropics, I found this statement extremely "provoking"; the reason being that I cannot refute it in any way.

How many times have I looked at utterly bizarre animals that seem to us so hopelessly 'lost' one is hard put to it to understand how they can even feed themselves, let alone reproduce? I could name hundreds that don't appear to be fit for anything! Maybe they evolved by natural selection, but the point is how have they managed to survive?

Personally, I still staunchly support the whole notion of "evolution", and not only of animals and plants, as being a natural process; and, while I equally subscribe to the basic principal as shown in the cartoon on page 30 of the April 1970 issue of PURSUIT, I find myself forced to agree with Mr. Smith that this theory (or practice) does not explain the "survival" business. Perhaps we just don't know enough yet, but it would seem to me that a factor which we should call "chance" enters the equation, so that hosts of of utterly ridiculous and inefficient animals survive

A Snail's Pace

"Hoven, England (UPI) — Colly, reputedly the world's fastest snail, has died at the age of 4. Owner Chris Hudson, 15, said, 'I don't think captivity agreed with her.' The funeral was held yesterday in Hudson's garden. Colly beat a host of challengers last May to win the world snail championships at Folkestone, England. The creature covered two feet in the record-shattering time of three minutes."

Probably over-exerted himself.

simply by default. So long as there is a niche for them, they just go on and on until they become so bizarre they they cannot reproduce any more.

The rhinos are in another class. However idiot they are —and they are— some niches still remain for them; they can still breed; and they are just to much for predators, including man —and even with rifles—to be bothered with as prey.

In fact, I'm beginning to wonder if modern man is not equivalent to the rhinoceroses. We are certainly equally demented; and there's really no purpose for us. About all we have accomplished so far of a constructive nature, is this "pollution" everybody is talking about, in which we don't seem to have achieved anything but the promotion of excessive algal growths.

BLACK PUMAS

In our October 1971 issue we yelled Help! on the question of melanism in pumas (otherwise called cougars, panthers, painters, mountain lions, and heaven knows what else!). We cannot say that we have been deluged with material, but we have received quite enough to indicate that melanism —the occurrence of black pumas in an otherwise tawny-coloured 'race'— is in fact quite widespread and is possibly increasing.

Member #210 promptly came through with two references, noting that "Stanley P. Young and Edward A. Goldman's Puma (Dover Edition, 1964) mentions a couple of sources re black pumas. A specific case of just such a cat having been killed in 1843 in the Carandahy River section of Brazil is cited, as well as a vague reference to specimens of South American pumas (black, of course) being taken 'from time to time'. In Victor H. Cahalane's Mammals of North America (Macmillan Co., 1961) this great one-liner is found on page 272: 'Melanistic or black cougars are known; cougars of Florida seem to run strongly to that "freak" color'."

Our major source of information, however, is Bruce S. Wright, who is Director of the Northeastern Wildlife Station of the University of New Brunswick, Fredericton, N.B. Mr. Wright has written one book about pumas, entitled The Ghost of North America, and is at work on a revised edition. He cites a book by William Thomas, Great Cats I Have Met; Adventures in Two Hemispheres (Alpha Publishing Co., Boston, 1896, p. 75-76), and in addition was kind enough to send us a copy of a paper he presented at the 36th North American Wildlife Conference in March, 1971, the Symposium on the Native Cats of North America. In this he devotes a section to melanism, as follows:

"No black specimen of Felis concolor has ever been collected in North America, but one has been shot in Brazil (Young and Goldman, 1946, p. 58). The repeated mention of black specimens seen in daylight

at close range demands some explanation. I once believed they were caused by the specimens being wet. To test this I went to Vancouver Island and followed a government cougar hunter until he killed a large male. I took the fresh hide and suspended it by its edges and filled it with water and left it overnight. The next morning I photographed it in color from all angles. I could not make it appear black.

"My next thought was that they must be backlighted. However, a check on the position of the sun at the time of these reports proved this theory untenable.

"I have now no alternative but to accept the word of the eye-witness that there are black specimens of Felis concolor in northeastern North America and that they are not particularly rare (about 7% in New Brunswick and Nova Scotia.)"

Mr. Wright appends a table detailing no less than 20 black pumas seen at close range in daylight in New Brunswick, Quebec, and Nova Scotia between September 1, 1951 and August 2, 1970, and notes that as many more were not included because the circumstances were such that positive 'identification' of the color was impossible, though he adds "There is no reasonable reason for disregarding these descriptions".

We also asked Lennie Rue —one of the very great naturalists in this country; see National Wildlife and International Wildlife for examples of his animal photography— if he had any references to black pumas. Lennie has a truly incredible library on natural history, with emphasis on North American mammals, but could not come up with a single reference. On the other hand, he pointed out that there is a claim from Borneo for a black Clouded Leopard (Panthera nubulosa) believed by many to be extinct, and that there is even a book called The Black Lion! We know of many albino tigers; has anyone references on black ones? Black leopards are quite common, and black jaguars are not rare, though most seem to come from a fairly limited area in the Guyana Massif.

And, just for the record, one of our subscribers tells us that some five years ago he talked with a chap from El Salvador who stated calmly that he occasionally hunted Bengal Tigers—"tigres Bengalis"—across the border in Honduras (not British Honduras); he said they had multiplied there since some escaped years ago from a circus, so, if someone tells you he hunted Bengal tigers in Honduras (provided you can get into that country safely —and out again), he is not necessarily a liar!

THE "WHAT'S-IT" FROM SOUTH DAKOTA

There has been a considerable uproar over an allegedly unidentified animal that was found near Bottineau, South Dakota, and eventually landed in the zoo in Minot, South Dakota (not North, as many newspapers reported). It was virtually hairless and generally in wretched condition; and some pretty silly statements were made by those who ought to have known

better. The animal was variously 'identified' as "possibly some kind of Kangaroo", possibly "a rat tail opossum", and this, that, and the other thing. The kangaroo bit was the result of the apparently excessively long hind legs. We called the director of the zoo, Mike Nilson, who stated that the animal is a Gray Fox suffering from a virulent case of a mange-like disease that has also been noted in red foxes, raccoons, and bears, and has, it seems, been endemic in the area for several years.

The Gray Fox is very different from the Red Fox, in fact so much so that its Latin name is Urocyon rather than Vulpes. Its proportions, gait, and habits are all distinct from those of the Red Fox, and it is a fairly agile tree-climber. It is also much less commonly seen than the familiar little animals chased by the "view halloa" crowd. Also, shave any animal, and you will probably have trouble deciding what it is.

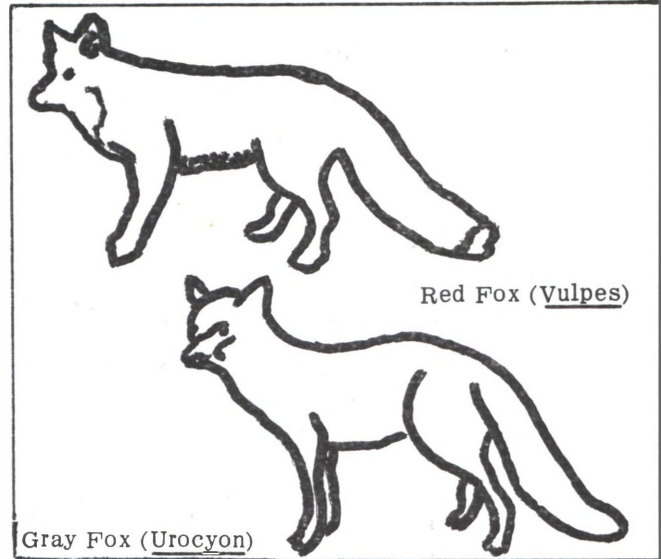

VIII. ANTHROPOLOGY

LIGHT WHEELS AND HOLOGRAMS THAT USE ACOUSTICAL RADIATION

by Robert J. Durant

Speculation is a tricky business, but one that is part and parcel of SITU's work. Reading an endless series of reports is tedious at best, but it is the speculation on these cases that makes the study of fortiana fascinating and potentially rewarding. My suggestion is that we keep a careful watch on technical developments in order to find analogies or clues to explain the nature and operation of the anomalous phenomena. (We are, as it were, in the position of a Volta or a Galvani faced with the task of explaining a TV set before he has "discovered" electricity.) This is admittedly a rather weak approach, but at least it saves us from the extremes of the occultists on the one hand and the weather-balloonists on the other. I believe that most of the mysteries we are dealing with will eventually be explained in perfectly logical fashion as physical forces and processes that are simply unknown at the present time.

Let us take, for example, those wheels of light discussed in Ivan T. Sanderson's Invisible Residents and elsewhere. These so-called "wheels" are actually spokes of light radiating from a central hub. Some reports give the spokes huge dimensions, on the order of 15 or 20 miles. These are the facts as we have them from the testimony of a great many mariners over a period of several centuries; and almost without exception from the Indian Ocean. The first organized speculation on the nature of this phenomenon appeared in Fate Magazine and again in Invisible Residents. This was the conjecture that the source of the light might be the excitation of a microorganism called

Noctiluca milliaries, a light-emitting single-celled organism that abounds in the waters where the wheels of light have been reported. It was further speculated that two strong rotating sources of sound waves could produce 'beams' of light. After considering and abandoning the possibility that pairs of mating whales might be the source of the sounds, Sanderson drops the subject to wonder whether a machine might be responsible!

In order to keep abreast of the latest inventions I make it a practice to read the Saturday New York Times financial section; this carries a summary of patents granted during the preceeding week. Most of it is pretty dull reading, but from time to time one hits a 'winner': "Apparatus for Constructing a Hologram Using Acoustical Radiation".

This article described a new device that takes three dimensional photographs (holographs) of the interior of solid objects, and does so by radiating the object with sound waves. The reflected sound waves are processed electronically and then changed into light waves which are in turn used to expose a photographic plate. Holographs have been around since the late forties but weren't really practical until the invention of the laser beam. Even today they are curiosities but there is considerable developmental work underway which promises to give us three-dimensional television in a few years. The technical breakthrough in this patent is the use of sound waves to make the holographs. The effect of using sound rather than light amounts to making opaque solid objects almost transparent. A holograph made with light shows only the exterior of the object; the sound holograph can show interior details.

In practice this means that one can take a 3-D photo of a cavity in a tooth or an air bubble in the

Feb. 2, 1971

K. PRESTON, JR
APPARATUS FOR CONSTRUCTING A HOLOGRAM USING
ACOUSTICAL RADIATION

3,559,465

Filed May 24, 1967

2 Sheets-Sheet 1

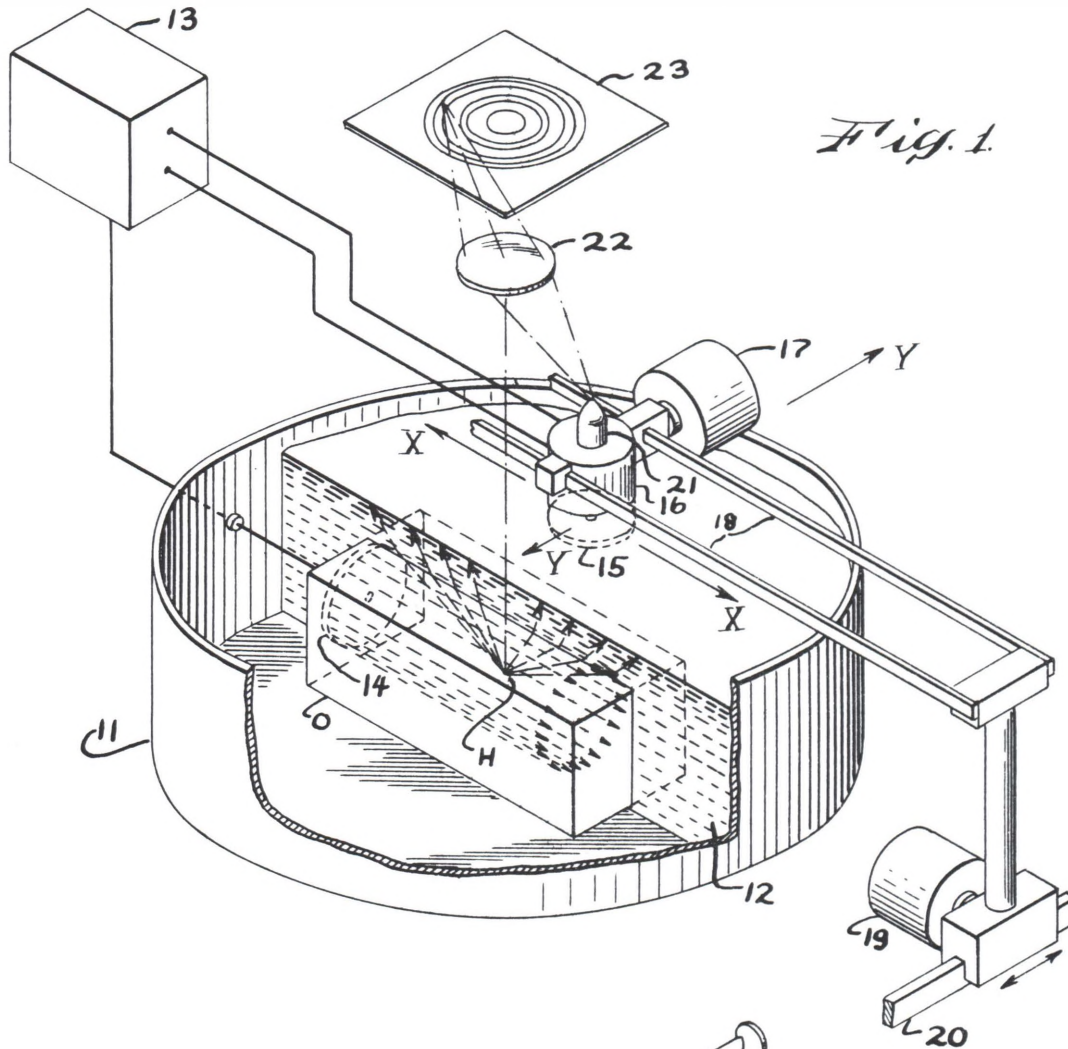

Fig. 1.

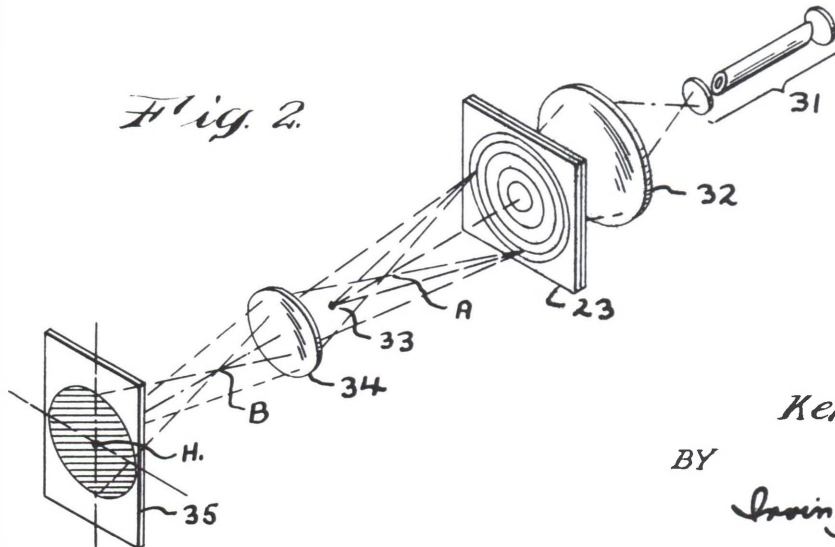

Fig. 2.

INVENTOR
Kendall Preston, Jr.

BY

Irving M. Kriegsmann

ATTORNEY.

center of a steel bar. The working model for the patent does exactly that. The inventor, Kendall Preston, Jr., of Norwalk, Conn., hopes to make holographs of the organs of the body. This would be a great advance for medical diagnosis (and, presumably, make things much easier for the patient, considering some of our present diagnostic techniques!), but, in my estimation, the significance of this invention is even greater, for it provides the next link in the chain of speculation on the wheels of light.

Suppose we were to want a three-dimensional photographic record of the caverns and the interiors of the "mountains" at the bottom of the sea. We could, using the principles established in this patent, build a device to do so. The device would require very powerful sound sources that would radiate in a beam. In order to record a large area this device would be equipped to move slowly across the ocean floor. It might also be convenient, for reasons of efficiency, to have a number of sound beams in operation at the same time, perhaps even revolving or sweeping in all directions. If there happened to be a large number of Noctiluca in these waters. . . .

So now the wheels of light are at least comprehensible* in terms of a known technology. We have a possible answer. In fact, we can make our own wheels any time we care to. By "we", I mean our terrestrial civilization. In the meantime, someone else seems to have beaten us to it by at least several centuries. The appearance of the wheels over such a long period of time would seem to preclude a simple exploration of the depths as the motive behind the phenomenon. One wonders if the sound beams are used to observe some process taking place deep under the sea bed. This would be an excellent way to keep tabs on the workings of a nuclear power plant or other machinery that must be shielded so that visual inspection is impossible. Immensely powerful machinery, emitting deadly radiations, hidden in the ocean deeps for centuries, inspected now and then by its owners —but perhaps this is going too far. Perhaps.

Note: To obtain a copy of Mr. Preston's patent, send fifty cents to Commissioner of Patents, Washington,

*With the exception of those most extraordinary "wheels" of which the spokes form flattened S-curves. This indeed is the real "stickler"; Bob Durant will present a possible explanation in the April issue of PURSUIT, but in the meantime we invite any suggestions or serious speculations on this score. Editor.

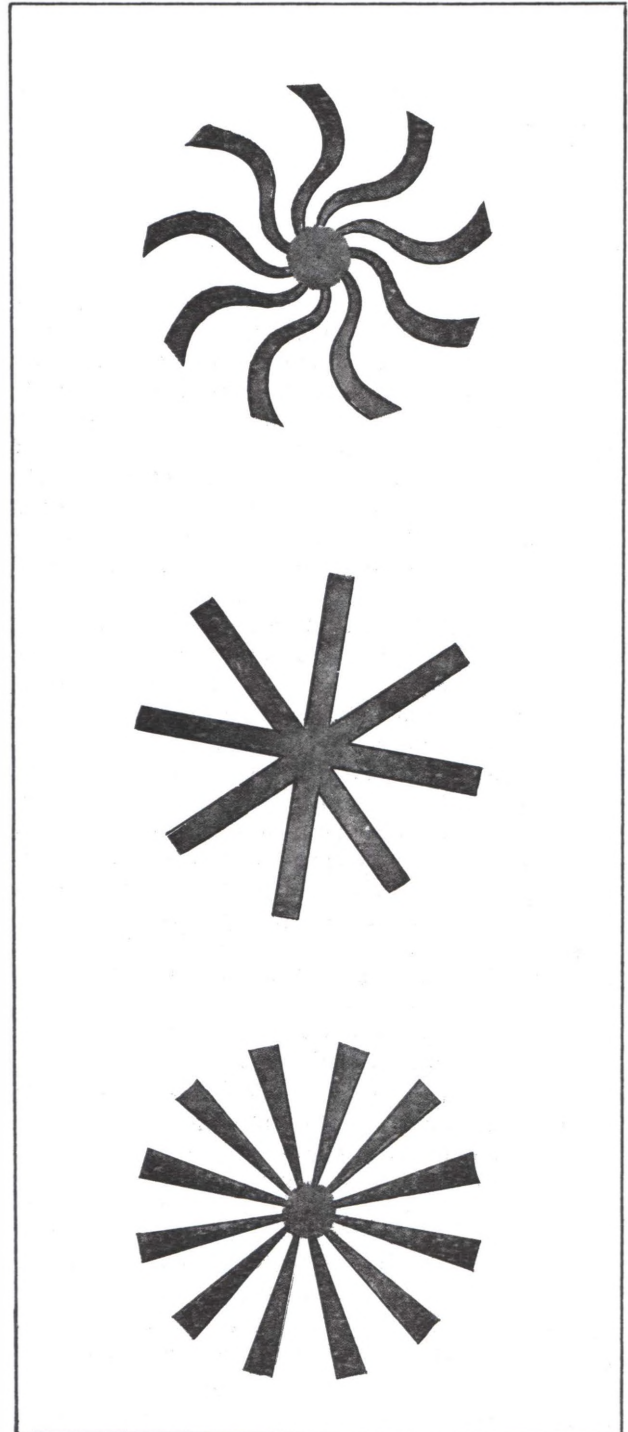

The Three Types of Light "Wheels"

Technology and the Useful Arts – Subsection Postal Service.

UPI dispatch from London: "Record Claimed For Delay In Postal Service. The following letter, from the Dean of Canterbury, Ian H. White-Thomson, appeared in today's Times of London: 'Sir: A few days ago I received a communication addressed to T. A. Becket, Esq., care of the Dean of Canterbury. This surely must be a record in postal delays.' Thomas A' Becket died in 1170 A.D."

DC 20231, and ask for Patent No. 3,559,465 Apparatus for Constructing a Hologram Using Acoustical Radiation. Holographs may be obtained from the Edmund Scientific Co., Barrington, NJ 08007. Write for their catalogue.

CULTURAL EXPANSION: WHICH WAY?

Once upon a time there was an area called Mesopotamia, and the people living there were frightfully bright and invented all sorts of things like iron, alphabets, agriculture, religion, pyramids, and what-not. (Admittedly, some of them insisted that they learned all this from somebody who "came up out of the sea" and told them how to go about it, but this is beside the point.) They were once alleged to have sent expeditions out to Europe and other unheard-of places, even Scotland, and taught the benighted natives there how to do all these things too.

This is probably too far-fetched even for PURSUIT, but the fact is that archaeologists and cultural anthropologists have always assumed that "culture" began in the Tigris-Euphrates Valley and slowly spread to Eurasia—both western, and as far as the British Isles; and eastern, as far as China e.g., Stonehenge has been believed to have been built at least with the help of the Mycenaeans. This belief was founded on the fact that only Egypt and Mesopotamia had calendars and thus chronologies, so that archaeological finds could be dated with reasonable accuracy. Finds elsewhere had somehow to be correlated with Egyptian and/or Mesopotamian artefacts. This was relatively simple for such places as Central Turkey and Crete which traded extensively with the former; but what to do about items popping up in northern Scotland or Transylvania? There was considerable argument about this for years, and it was not until the 1920s that the dispute subsided somewhat with Gordon Childe's theory of "modified diffusionism". This simply implied that European cultures were built on Mediterranean 'foundations', and resulted from some kind of inter-course—whether commercial or religious—beginning between the two areas, circa 2500 B.C.

Some 21 years ago, radio-carbon dating was discovered and, though it has never been considered infallible, it was believed to provide reasonably accurate dates for organic materials. Thus, a grave could be dated within, say, a century or so, if it contained bones, wooden implements, or the like. The method was applied to many sites, and it seemed to prove Childe's theory, since the dates that came from the computers were roughly those that the investigators expected; i.e. they conformed with educated guesses about the time required for a particular style of pottery, for example, to have been 'transmitted' to the area in which it was found, from the area in which it was assumed to have originated. However, studies of carbon-14 dating data have been correlated with the more accurate chronology provided by tree-ring

counts (specifically those of the California Bristlecone Pine), and indicate that some major revisions are necessary. This has led to a considerable uproar in archaeo-anthropological circles, the chief instigator being one Colin Renfrew, a senior lecturer at the University of Sheffield in England.

Using the new C-14 dates, he has produced a fund of evidence that civilization began in northern Europe and made its way down to the Mediterranean! Many artefacts from northern Europe and the British Isles are, in fact, from 700 to 1000 years older than they were previously thought to be. Renfrew admits that simultaneous invention may account for some of this presumed "diffusion" of culture. This process, which has always been recognized by archaeologists but has not perhaps been given the 'weight' due it, is still going on: Mr. A. in England invents a "thingummy", only to find that Mr. B., in Chile, invented a "thingummy" at the same time. There is thus no reason to insist that only one person or group 'invented' the production of copper, or whatever.

The consequences of all this are considerable and, if Renfrew is right (his theory has not exactly been welcomed with open arms or shouts of glee from his fellow archaeologists), a number of rather peculiar 'items' might be clarified.

Carbon-14 dating will not help much in straightening out one of the most puzzling mysteries facing the archaeologists, since this involves the sometimes enormous stone monuments found scattered all over the British Isles, France, Spain, and elsewhere. In some cases these were tombs and contain dateable items, but in others not a single scrap of such helpful material has been found; and the experts have a tendency to indulge in circular reasoning: i.e. this one is better built than that one; therefore it must be of later construction, etc. This is debatable, particularly if no definitive date can be assigned to either. (One pair of experts manage in one paragraph to date Maes Howe, a structure to which we will return shortly, at approximately 900 A.D. and 2200 B.C.!

Probably the best known megalithic monument (mega—large; lithic—stone) is Stonehenge. It is, by the way, a great disappointment when one sees it for the first time, since most photographs have, apparently deliberately, been taken to make it look as if the standing stones should at least reach cloud level. However, careful study of the site even by a non-expert soon leads to considerable respect for both the engineering skill and the mathematical precision of the builders. It was constructed in several stages, and I do not know what the "new" dates (i.e. Renfrew's, if he has done anything about Stonehenge) are. The Mycenaeans "got into the act" in a rather peculiar way. It is popularly believed that the representation of a Mycenaean double-ended blade axe was found on one of the stones by a schoolboy some years back. In fact, the official handbook published by H.M. Stationery Office (1955) points out that "No less than twenty-five [incisions representing an early type of bronze axe]

are on the outer face of stone 4 and originally about a dozen were on the inner face of [stone] 53. Here there is also represented a Bronze Dagger; owing to weathering, its exact type is not certain." They add that it is impossible to say when these axe blades were incised on the stones. There are other carvings on stone 57 "which were being gradually obliterated by visitors walking on them". Ergo, there is no positive evidence that the Myceneans had anything to do with it —so far as we can see. The only positive thing about Stonehenge is that it was constructed as an astronomical "observatory". The debate on its accuracy as such is still going on, but the basic function is no longer in doubt.

The function of Maes Howe near Stennes in the Orkney Islands off northern Scotland is now very much in doubt, though orthodox archaeologists insist it is/was a tomb. It is a remarkable structure, but was, unfortunately, vandalized by the so-called Vikings about the year 1200 A.D. They scratched their 'initials' in the walls and noted that they had carried off "treasure"; they made no mention of throwing out old bones. It has always simply been assumed that it must have been a tomb.

It is a cone-shaped pyramid 27 feet high and 115

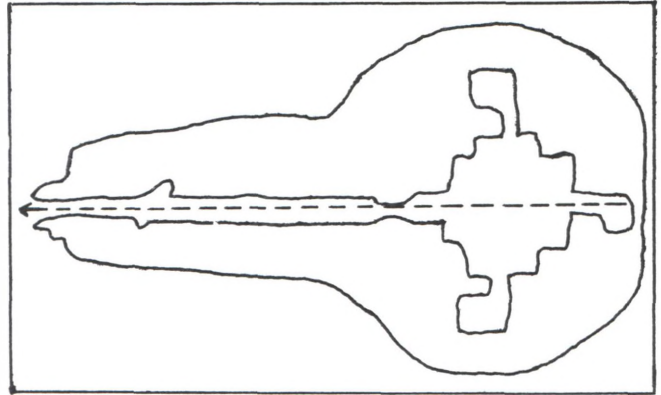

Maes Howe —"floor plan"

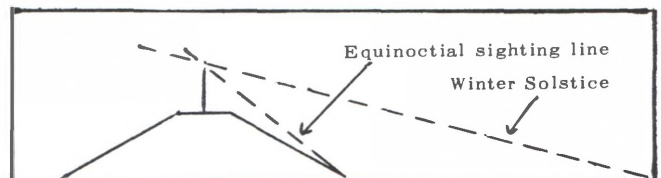

Silbury Hill with maypole on top, showing seasonal shadow lengths.

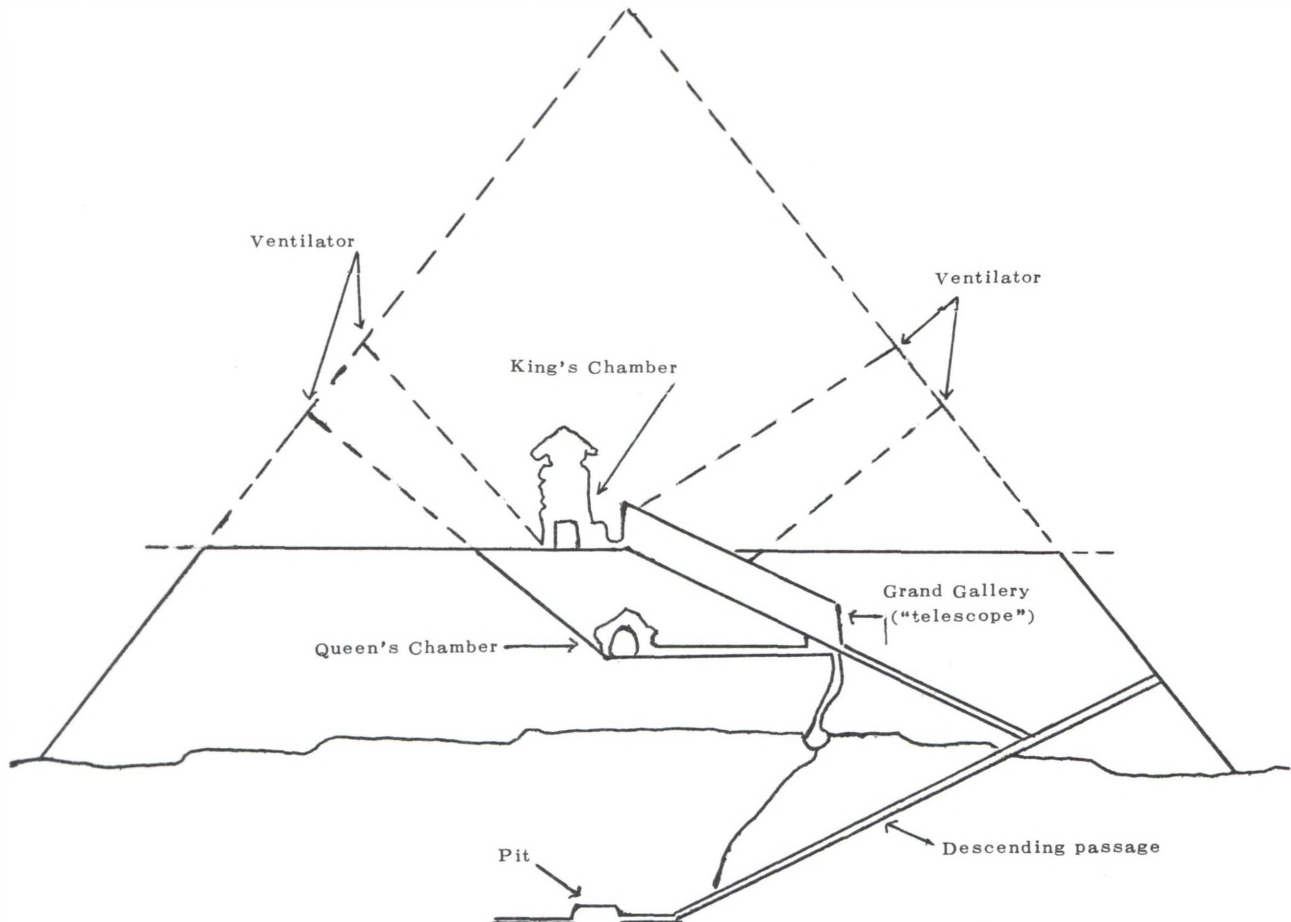

The Great Pyramid of Cheops, sliced in half, as it were, to show the interior construction. The passage leading to the "King's Chamber" was initially an astronomical "sighting tube", much like a telescope.

feet in diameter, with a 45-foot-wide ditch, 700 feet in circumference, encircling it. Inside this mound there is a 54-foot-long passage leading to a chamber 15 feet square, with three small rooms leading off the main chamber. The roof of the main chamber is corbelled and could be closed at the top by a single moveable slab. This interior construction is all megalithic, and the stones are set so closely that a knife blade cannot be inserted between them. In a direct line with the passageway, and 2772 feet away there is a monolith or single standing stone. At the present time, the sun rises directly behind this monolith 10 days before the winter solstice. There is another monolith to the west, apparently to indicate the equinoxes. If the astronomers would get into this business, we might find an at least approximate date for Maes Howe. It is much more likely that it, too, was an astronomical observatory.

In fact, astronomy seems to have been practiced throughout the British Isles, Denmark, Sweden, France, and Spain. Britain generally is littered with small barrows, as they are called, and these are burial mounds — many have been excavated. But what does one do with a mound that covers 5 acres and contains an estimated million tons of earth, sitting on a flat plain. We refer here to Silbury Hill in Wiltshire, which was definitely manmade, has a truncated top, and probably sported a maypole at the top — a maypole whose shadow could be measured on said flat plain to determine the passing of the seasons.

All of these monuments required both considerable knowledge and an enormous amount of work. One doesn't drag 45-ton stones around and then set them upright just for the fun of it. These sites were important to the people who built them. What is important to us is that the degree of sophistication shown in their construction does not show any nice neat pattern from south to north — or vice versa. Maes Howe is about as far as you can get from the alleged birthplace of civilization, but it shows almost uncanny affiliations with the Great Pyramid attributed to Cheops. If the sun at the winter solstice has shifted ten days, as it were, the structure at Maes Howe may be a great deal older than Cheops' Pyramid. Too, it is odd that Cheops' wife is depicted as a blonde in her daughter's tomb. It is easy to dismiss this by saying simply, oh, well, she was wearing a wig. But, why blonde? Whether the legends quoted by one Otto Muck, about whom I know nothing except that he has written a book about Atlantis (which does not automatically or necessarily disbar him from polite company), that Cheops married a light-eyed (blue?), reddish-blonde female from northern Europe and then married their daughter off to another northern European, are valid I do not know, because I do not know his sources. But he adds that the change in the Egyptian calendar from a stellar to a solar base, was the work of a light-skinned European. None of this proves anything, but it does suggest that perhaps Renfrew is right, or at least on the right track.

You may now wish to skip on to the book reviews for more on pyramids.

FOOD FOR THOUGHT

The following was sent to us by a gentleman who works for IBM and is also a professional pilot. He wrote several weeks after finishing Invisible Residents, stating:

"I would like to carry the basic findings you have made a step further by proposing the following:

"A. That interstellar travel in the center of the galaxy would pose very few problems due to the relative closeness of the individual stars.

"B. Because of A, the developing planets would simply move to other planets as room was needed.

"C. Also because of A, there would be very little development of social sciences because want of room or resources could be solved by B.

"D. Because of the wealth of planets, a great variety of different intelligent beings would develop.

"E. At some point, some scientist would begin to realize that some day there would be no more room, or that resources would begin to become harder to reach.

"F. In an attempt to find out the reaction to E, an expedition would be sent out to the edge of the galaxy to find a remote and isolated planet that was just beginning to develop some sort of intelligent life.

"G. Using advanced biological techniques, they would advance the development of the highest form of life in one giant step. This would eliminate the need to wait for nature to do this for them.

"H. They would then start accelerated civilizations in different areas on the planet and study their growth. "Disasters" and "want" could be induced artificially.

"I. That the expedition would be in a position for extended surveillance due to the flexibility provided by D.

"J. As the experiment developed to the point where the cultivated intelligence began to be openly aware of the outer influence, the surface surveillance was turned over to the part of the team that lived under water.

"K. The surface part of the team left for home, promising to return someday. They left a spare ship parked nearby for the rest of the team to leave when the experiment had run its course.

"L. That things are getting tight for the team that is left, because it is getting harder to hide all the time.

"M. That we were that planet."

Bear in mind that this is pure speculation on the part of Mr. C. But remember also that the incredibly rapid development of Man and Culture is something that has bothered anthropologists, both physical and cultural, for years. And then there are all those archaeological 'horrors' that are either ignored, swept under the carpet, or 'explained' away because they don't belong there.

DEPARTMENT OF LOOSE ENDS

We have not yet acquired a copy of the article on the Indian non-rusting pillar from the Czechoslovak Chemical Communications, vol. 36, p. 625, and so cannot comment further on this. One of our 'spies' has been tracking this down: his first try ended in "That's the only issue we have failed to receive", and his second—the National Library of Medicine in D.C.—produced the article; but they have no copying facilities and will not permit people to bring in their own copying machines! We promise to report further.

On the Arkansas White River Monster: For those who are made 'nervous' by giant penguins, we refer them to Ivan T. Sanderson's book More "Things", chapter 3. Dinosaur three-toed prints do not match those of "Old Three-Toes" (Model B). They do match those of penguins.

Next, member #976 notes that Putnam's The New Field Book of Reptiles and Amphibians, 1970, states that "In the United States, alligators grow larger than crocodiles. Adults usually range from 6 to 12 feet in length, but the maximum is more than 19 feet [emphasis ours]." One of the authors of this book is Doris M. Cochran; we trust her. And our original figure was

obtained from the Cambridge Natural History Series, a splendid set but dating from the 1920s. Member #976 also notes that a 19th Century newspaper account, accepted by the Fish and Game Department, recorded a Mississippi alligator that measured 28 feet!

Member #164 suggests that the photo on page 92 of our October 1971 issue looks like a fishnet with floats and an odd-shaped rock, and adds "I wouldn't go next door on the basis of that alone". This is, of course, a possibility, but one must still explain the "spray" at the 'other end' of the fishnet. Also, it is our impression that the White River is a rather popular fishing area and that such a rock would be known to the local people. Also, rocks don't produce footprints. #164 goes on to say "And as to tracks, a local (N. Fla.) editor-writer, Thomas Helm, I think, who wrote the worst book on sharks ever published, recently had a Sunday supplement feature in which he said he had all the evidence on your (ITS) long-ago three-toe search in this [Florida] area; that it was a hoax and he could name the hoaxers, and how it was done?" For these "hoaxers", we again refer you to More "Things".

CURRENT PURSUITS

THUNDER BIRDS

Will someone kindly find us that photograph?????

ANDREW CROSSE'S ACARI

Our member #621 has begun a campaign on behalf of Andrew Crosse who, in the early 1800s, apparently created life by sending electrical currents through vats containing deadly chemicals. Crosse was vilified in his own day and has been ignored since. The "life" he created was not simply strings of amino acids or such, but "bugs" as it were. He kept careful records and, so far as we know, did effectively sterilize the materials he used. What member #621 has asked approximately 50 scientific institutions is simply that they attempt to duplicate Crosse's experiments. His first letter, to the American Institute of Biological Sciences, was returned—the original letter—with the words "No information" scrawled across it. His second reply boiled down to a "It's up to somebody else to prove that it is worthwhile trying this experiment before any scientist should waste his time on such garbage" (this is not a direct quote; it merely indicates the sense of the reply). We would suggest that our members and subscribers, writing as individuals and not identifying themselves as members of SITU—which frankly does not have the resources for duplicating this experiment—bombard every

scientific organization they can think of with the 'suggestion' that Crosse's work should be checked. No one has really ever defined Life, and Crosse—if his experiments were as he reported them—did create Life. He at least deserves a hearing. For those of you who are not familiar with Crosse's work, we will make up a brief précis so that you can make clear what you want done. Any who want one will help us enormously by sending a stamped addressed envelope. Just address your request to Andrew Crosse, Esq., c/o SITU, Columbia, N.J. 07832. "No information": and they call themselves Scientists!

A LONG SHOT

Member #52 has been attempting to find a correlation between magnetic storms and various fortean phenomena, particularly poltergeist manifestations. His findings thus far show a rather remarkable correlation but, as has been pointed out by member #255, trying to correlate isolated events with world-wide phenomena is a very long shot indeed. Nevertheless, it would seem to be worth following up for a time at least—and there may be specific factors connected with magnetic storms that 'trigger' such fortean phenomena. What #52 needs is data on magnetic storms—i.e. definite dates, intensity, etc.—and data on fortean phenomena with definite date of onset or occurrence. Anyone willing or able to assist #52 should contact us; we will put you in touch with him.

MEMBERS FORUM

In this column we will henceforth present special requests from members which cannot be handled by our staff for various reasons. Unless they specifically ask that their names and addresses be given, they will, as usual, be identified by number only, and correspondence should be addressed to Member #007, c/o SITU.

(1) Member #607 would like to get in touch with all members in Connecticut, possibly with a view to setting up a Connecticut "chapter" (would someone kindly think up a better name —the N.S.S. or National Speleological Society uses the word Grotto!).

(2) Member #909 in Laird Hill, Texas, would like to correspond with members in his area —as far as we can make out, he lives near Dallas; Laird Hill is not in our atlas.

(3) Member #432 is interested in acquiring early books on UFOs, specifically those predating 1956.

(4) For all of you who have wondered but haven't dared to ask: that "thing" on the front of PURSUIT is a DOG, not a mouse, snail, or whatever. It used to chase question marks, but they got lost somewhere along the line. The doggie was Ivan Sanderson's "trademark" for years; he used to autograph books with it and such. It is now ours.

Additions:

Add to the Index in the October 1971 issue of PURSUIT: "Those Damned Vimanas Again", III:79. I don't believe we missed anything else.

BOOK REVIEWS

Correction

Odette Tchernine informs us that she was, in fact, brought up in England; and also states "The reason I deliberately did not read [Ivan T. Sanderson's] book. . .when I was preparing 'The Snowman and Company', and during the last two years I was working on 'The Yeti' was because I wanted to conduct my own investigations with no risk of being unconsciously influenced".

John A. Keel. Our Haunted Planet. Greenwich, Conn.: Fawcett Publications, Inc. (Gold Medal Paperback). 75¢.

The content of this book only fringes upon our particular field, which is the tangible unexplained mysteries of natural history, but it is profoundly fortean in its approach to matters that are primarily intangible, at least in the dictionary sense of that word. This is not to say that items like Atlantis and disappearing nuclear submarines are not tangible indeed but that the author tackles, and not just boldly to say the least, the much more difficult and weird intangible aspects of all these things. The reports given in this book are, naturally, secondhand and most of them almost old-hat to forteans; but, strung together and assembled this way, with almost breathless, and often staccato, journalistic cadence (Keel is a journalist), they certainly make one sit up, or back, and think. The details in quite a lot of these cases are either inaccurate or at variance with other published accounts. However, I would not put it past Keel to have dug out the true details.

If you really want to have some fun, bring up John Keel's name at any gathering of scientifically trained folk, pseudoscientists, religionists or pseudo-religionists, or cultists of any kind, and most notably the ufologists and saucerians. Frankly, it is now my belief that he does not just embarrass them by quoting from their own published statements, but terrifies them with his theorising: both of which, I may say, he does in exactly the same manner as the old man himself. John Keel is a lot more polite and far less dogmatic than Charles Fort, but he knows just as well where to stick in the barb and then how to twist it.

His general theory is, of course, utterly horrible to just about everybody but, as one turns the pages of this book, one finds oneself constantly sucking in one's breath and mumbling something like "Oh no! Not that too? But now I come to think of it".

I was once involved in a scholastic debate on matters entirely pragmatic when his name came up, and a geophysicist with a full doctorate, and a Jesuit Priest at that, casually remarked: "Now there's one thinker who's got guts". I was speechless, and not only because I had never expected this scientist to

have even heard of John Keel, but because it was Keel who really first put forward the idea of ultra-terrestrials — years before scientists such as Dr. Jacques Vallee. He tackled this in two previous books (Strange Creatures from Time and Space, Fawcett; and UFOs: Operation Trojan Horse, Putnam) and it boils down to an analysis of the history of deliberate interference in human affairs since ever by other intelligencies of various status and origin, invisible or tangible, and both what we call “good” and “evil”. This is not a likely commendation to a professional geophysicist or a Roman Catholic priest!

The book is beautifully done by the author, but the publisher and/or he are to be most roundly condemned for not going to the trouble (despite the admitted expense) of a full bibliography or table of numbered references; and, even worse, for not providing an index. If they are in business to sell books, the publishers at least ought to know that these are essentials for a book of this nature, as it could one day become not only a classic but a reference work of very great and lasting value. Back-tracking through 222 pages of packed small print to find even one’s own name depresses both me and my ego. But get the book —all of you.

Ivan T. Sanderson.

Brad Williams and Choral Pepper. The Mysterious West. New York: World Publishing Co. 1967.

When this book arrived as a gift from member #272, our eyebrows went up slightly, since its exterior hardly looked like our kind of thing. However, the first several chapters, and sections of others, are purely fortan; and the remainder is great fun as well. Though there is not a single specific reference the authors have obviously done their homework. Unfortunately there is no index though, in this case, the lack is not disastrous. The Epilogue is priceless.

H. Y. Li and Sibley S. Morrill. I Ching Games. San Francisco: Cadleon Press. 1971. \$5.95.

I would dearly love to spend about four pages talking about the I Ching games (pronounced Ye Ching), but it is not fortana as such. However, it provides a peculiar kind of mental exercise that is potentially very valuable to fortans (and other mortals); in fact, I can recall one incident in which such an exercise would have saved us the cost of a call to Scotland! The book comes complete with playing pieces for both the Seven Game (the Wisdom Plan) and the Fifteen Game (the Beneficial to Wisdom Plan). You should be warned that it can be utterly exasperating, finally exhilarating, and is definitely habit forming. Order from the publisher, P. O. Box 24, San Francisco, CA 94101.

Just to whet your appetite, herewith the pieces that make up the Fifteen Game (on the left) and one of the “diagrams” —the Tai-Chi”; there are at least three ways to solve it —Messrs. Morrill and Li and I all came up with different solutions.

Afterthought: You must use all the pieces; they may not overlap.

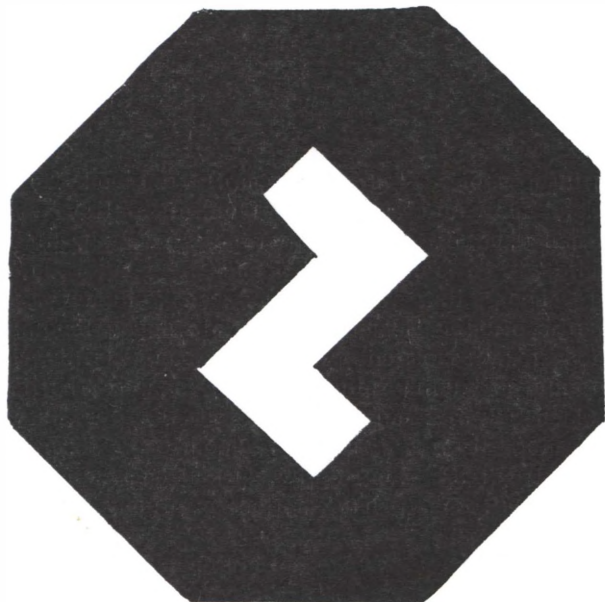
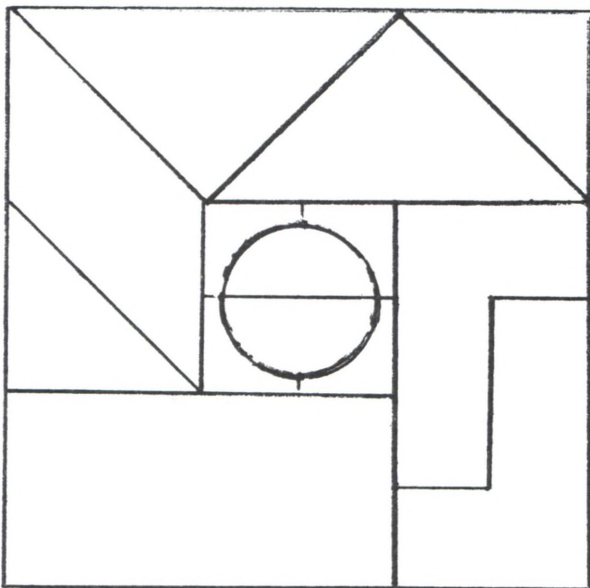

Norman Brennan. Flying Saucer Books & Pamphlets in English: A Bibliographical Checklist. \$3.00.

For those interested in ufology, this is well worth having. It catalogues 390 books and pamphlets and includes a title index. Order directly from Mr. Brennan, Box 2662, Buffalo, NY 14226.

Peter Kolosimo (trans. by A. D. Hills). Not of this World. London: Souvenir Press 1970. 1.75 (35s).

This is a very odd book and while reading it I had constantly in the back of my mind the old joke about the chap who appeared in divorce court, presenting as grounds for divorce the fact that his wife talked all the time; when asked by the judge what she talked about, his reply was, "I don't know; she just don't say!"

In general the book deals with evidence of various kinds that this planet has been visited by and/or deliberately 'planted' by extra-terrestrials, the latter either "from scratch" or by 'manipulation' of animals already here. The author uses both myths and legends (including also written records) and tangible items such as monoliths, out-of-place objects, etc.; interspersed on occasion with, of all things, quotations from H. P. Lovecraft and Murray Leinster, "quotes" from virtually unidentified (or at least so minor as to have escaped notice) "explorers", with no date or anything else by which one might check his information. He includes some most interesting material, but there is no index, and no bibliography, and his "references" in the text are so vague that, in general, they are worthless. In some cases it is nearly impossible to tell whether he is quoting from a document (he is particularly fond of the Maya Popol Vuh) or whether it is he who is 'talking'.

He also makes some rather monumental goofs, claiming that Musk Deer have been found in Antarctica (though it really is not clear who claimed this); and some of the errors may be the fault of the translator—e.g. the famous "metal cube" found in an Austrian mine in 1885 is stated to be in the Salisbury Museum; he means Salzburg, of course: translator asleep at the typewriter? And someone should have been a bit more judicious in his choice of an adjective to describe the Milodont: "a tardigrade or slow-moving animal thought to have been extinct since prehistoric times." The adjective "tardigrade" is perfectly legitimate—though the phrasing is redundant—but there is an animal called a tardigrade; see cut below—and Milodont bears no resemblance to it, being one of the giant so-called Ground Sloths.

The book is perhaps best described as an interesting conglomeration of facts, legends, rumours, reports, etc. and would be rather valuable IF the book had an index and references. As it is, the book is, to be blunt, "toilet literature". And the author never really makes his purpose in writing it (other than paying for groceries, of course) clear; he does not speculate at any length, has no introduction (in the British version at least; I do not know if it has yet been published in the U.S., though it is available in Canada from the Ryerson Press, Toronto 2, Ont.) or epilogue. There are a fair number of photographs, many of them the same ones that have been turning up in every other book of this type but with some new ones as well, a number of which don't seem to be mentioned in the text. I do not guarantee this last, since I had a tendency to fall asleep while reading this book.

Despite all these reservations, I believe the book is worth buying, but I do suggest that you keep handy a large supply of small slips of paper to be stuck into the book, with appropriate annotations. In other words, make your own index.

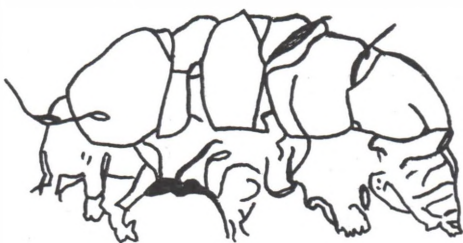

Tardigrades, otherwise known as Bear Animalcules or Water Bears, are a subphylum of the Arthropods; in fact, one zoology text notes "They are doubtfully placed among the arthropods". For a full account of these incredible animals, see Chapter 16 of "Things" by Ivan T. Sanderson. The drawing here shows a Tardigrade magnified about 50 times. (From a drawing by Ivan T. Sanderson)

Peter Tomkins. Secrets of the Great Pyramid. New York: Harper & Row, 1971. \$12.50 (With a long Appendix by Dr. Livio Catullo Stecchini.)

This is a splendid book, lavishly illustrated, and should be in every fortean library. Do not be misled by the review of it by our member and old friend Dan Cohen in Science Digest. It is true that the term "pyramidology" has come to have a perfectly frightful connotation, with visions of Madame Blavatsky et al., but it is grossly unfair to say, as Dan Cohen does, that "the greatest part of the book is devoted to trotting out

practically every loony theory that has ever been proposed about this ancient monument". Some of the "lunatics" whose theories are discussed in detail in Tompkins' book are C. Piazzi Smyth (Astronomer Royal for Scotland), William Flinders Petrie, John Greaves (Professor of Astronomy at Oxford, some of whose work on the pyramid was used by Isaac Newton in formulating his theories), Sir Norman Lockyer, Sir John Herschel, Jean Baptiste Biot, Richard Howard-Vyse, Edme-Francois Jomard. . . a fine bunch of "nuts". The problem here is that probably most people are not mathematically inclined and have trouble balancing their check books. Therefore, if someone comes along and says that the structure of the Pyramid incorporates the value of pi (π), the reaction is, Oh yeah? The mathematical 'explanation' of this fact is so far beyond us ordinary mortals that it is ignored, being quite simply unintelligible to us, and the pronouncement is put down as fantasy.

The book begins with an extensive history of visits to and exploration of the Great Pyramid from the ancient Greeks to contemporary Americans and others, but it is Tompkins' detailed description and analysis of the modern surveys and examinations of the Pyramid and the conclusions reached by scientists, that interest us most. Even if we devoted an entire issue of PURSUIT to these findings, we could not give you a full picture. In fact, I sat down with pad and pencil and attempted to list the various "bits of information" incorporated in the Pyramid and gave it up as a bad job; and these included only those which have been approved by modern science, but still short of certain current speculations; and none of the Blavatsky-type pronouncements.

To list a few of these items: The structure of the Pyramid incorporates, in several ways, the value of pi (π) accurate to several decimal places: the sacred 3-4-5 and $2\sqrt{5-3}$ triangles ($a^2 + b^2 = c^2$) that made the Greek Pythagoras famous; the "Golden Section" beloved of both architects and artists — phi (ϕ) in Greek — and also the one "thing" that provides for translating spherical sections into flat ones (map projections!) the Fibonnaci series (1-2-3-5-8-13-21, etc.) "discovered" by Fibonnaci, otherwise called Leonardo da Pisa, in the 13th century A.D.; and the direct relationship between pi and phi ($\pi = \phi^2 \times 6/5$). In fact, for all practical purposes, the Pyramid does "square the circle": "The Pyramid's base is a square whose perimeter is equal to the circumference of a circle whose radius is the Pyramid's height". You'll find all the mathematics in Tompkins' book; in most cases understandable even to mathematical morons like myself.

The Pyramid functions as an almanac, indicating the length of the year, including that damnable .2422 fraction of a day. It serves as an admirable theodolite for surveying, and in fact, was apparently intended to represent a scale model of the hemisphere, incorporating the geographical degrees of latitude and longitude (something we did not manage to measure accurately until about 1760). Just as an example, it has been calculated that 1 minute of latitude at the equator equals 1,842.9 meters; the base of the Pyramid has a perimeter intended to represent 1/8 minute of a degree — i.e. by actual measurement, twice the perimeter of the base is 1,842.91 meters! The Pyramid was a very carefully placed geodetic marker, oriented to true North, and so accurately that compasses are adjusted to it now, not vice versa. Its major use, though, would seem to have been as a stellar or astronomical observatory.

There is an empty "coffer" in the so-called King's Chamber which some contemporary scientists believe to "contain" information on the "mean length of the earth's orbit round the sun, the specific density of the planet, the 26,000-year cycle of the equinoxes, the acceleration of gravity, and the speed of light". Other investigators have come up with totally different explanations for the purpose of this coffer (which, unfortunately, has been chipped rather badly at one corner by idiot tourists, making it impossible to get totally accurate measurements). As Tompkins puts it: "Would it not be worthwhile. . . for academic institutions, so admirably equipped with computers and talent, carefully to analyze such conceits [the information listed above in this paragraph] as those of Alvarez Lopez and Funk-Hellet and either refute them or support them with reliable data? Some of their ideas may turn out to be no wilder than those for which Jomard, Taylor, Smyth, and maybe even Davidson were unjustly lampooned."

All of this eyebrow-raising information is only a sampling of the data either believed or proved to be 'contained' in the Pyramid. Its validity depends almost entirely on accurate measurement of the Pyramid, and this is where Dr. Livio Catullo Stecchini comes in. His speciality is ancient measurements, and his rather lengthy Appendix in this book details his search and research into the correlation between the various measures used by the Egyptians (and others) and our present measurements. This becomes pretty frightfully technical, and you may skip it if you wish; but you had better take Tompkins' word for it that various measurements given are accurate. Dr. Stecchini has worked on this over a period of many years and is respected authority on the subject. I admit that just measuring the Pyramids makes my mind boggle, particularly the most recent measurements which are accurate to the last millimeter! (with the exception of one figure which was given as plus or minus 6 millimeters).

Tompkins makes it abundantly clear that the Pyramid is invariably attributed to Cheops (spelt Khufu) though there is, in fact, no definitive proof that it was that Cheops who built it, or even that a Cheops built it; but it was obviously constructed originally as an astronomical observatory and a geodetic marker. He is equally clear on the point that no one has yet come up with an unassailable answer as to how it was built or by whom. If you insist that all the "information" incorporated in it is due simply to chance or coincidence.

our feeling that such insistence is even “worse” than attributing it to knowledge obtained somehow by the early Egyptians from somewhere else, or somebody else. Certainly one can postulate an incredible genius who somehow popped up in Egypt, like one Im-Hotep; but even such a genius as Leonardo da Vinci could not get his contemporaries—who were exceptionally open-minded and forward-thinking—to accept even half of his inventions. His paintings were perfectly splendid, and some of his “cannon” and such most useful—but heavier-than-air flying machines. . . .my dear chap, impossible! Even allowing a genius, and the fact that the quarries where the stones were cut are known, it still defies explanation. And in more than one way.

There are all sorts of internal “structures” in this pyramid that have puzzled archaeologists for centuries; either their purpose or their methods of operation, as it were, lead to all sorts of, sometimes rather hilarious, “explanations”. Tompkins makes no bones about this. (Someone having removed my marker, I cannot find a particularly priceless quotation which I had hoped to use; but it has been suggested, sensibly, that the pyramid was originally built only half-way up—i.e. picture a pyramid with the top half chopped off—page 17—to permit the necessary astronomical calculations to be made—and then the builders solemnly went on to add the top half even though it wasn’t needed. The gentleman did not explain how this was done. Or, if such was the case, why.)

As if all this were not enough, the Pyramid preserves bodies even today, mummifying them in a matter of weeks, completely without putrefaction, though there is no evidence that it was ever used as a tomb. The chap who first noticed this (dead cats kept turning up in trash cans for tourists inside the Pyramid; but why or how no one knows) wondered whether it was a property of this specific pyramid or whether it was the specific shape of this “shape” of pyramid that was responsible. He built a small wooden replica and put all sorts of odds in it, such as calves brains which are notorious for rotting quickly; they didn’t. In fact, anything placed in a pyramid built to the scale of the Great Pyramid is preserved indefinitely—and razor blades re-sharpen themselves! You figure that one out.

The book is very readable, though you will find that you must take it slowly. As noted initially, it is lavishly illustrated, and the captions—which are sometimes lengthy—are closely related to the text and are ‘must’ reading. In fact, the whole book is ‘must’ reading.

Harking back to our article on cultural expansion, we can and may indulge some speculation—and speculation it is. Considering the “average level” of culture in Eurasia, it seems unlikely that such sophisticated knowledge as is apparently incorporated in the Pyramid, could have been figured out in such a (relatively) short space of time. Do we, or may we, assume that visible, uninvited visitors came to earth in “Europe”, taught them various mathematical, astronomical, and other techniques; found the northerners a bit “uppity” and lambasted them (literally—vide the fused forts in that area); and that some of the initiates or priests who still held this knowledge fled to the south where, because of their extraordinary knowledge, they were given a home and passed on to some ancient Egyptians and Mesopotamian peoples at least enough of their knowledge that the latter could build, both figuratively and literally, on that information? Such knowledge would have been so valuable it would not have been passed on to the masses, who had to be controlled if they were to be “persuaded” to indulge the labour needed to build the Great Pyramid. In time the knowledge decayed and finally was lost almost completely; but the remaining bits and pieces were enough to give the ancient Greeks a start, and thus Pythagoras, Erathosthenes, Hipparchus, et al. became famous for their “discoveries”, which they deduced from fragments of ancient Egyptian knowledge.

Tompkins does not say all this, though he hints vaguely at “outside influences” in the early part of his book; and there is no proof of this thesis—but read The Secrets of the Great Pyramid and then consider the new evidence concerning the age of European culture by Renfrew.

Alma V. Sanderson

26 September 1909 – 18 January 1972

As many of you know, Alma Sanderson was stricken with cancer in April of last year. She ‘ought’ to have died in June, but instead made a remarkable recovery which we all hoped would prove to be a cure. However, in mid-December it became clear that the cancer in her brain had been knocked down but not out. She was readmitted to hospital on the 29th December and died on the 18th of January.

For those who would like to show their sympathy in tangible form, we propose an Alma Sanderson Memorial Fund, all the proceeds to be used to further the work of the Society—the only “child” Alma and Ivan T. Sanderson ever had. But please, no condolences, no sentiment. Alma’s body, as she wished, has been given to a medical institution to further research in cancer and other diseases. This and the continuation of SITU’s work are all that Ivan wants.

THE SOCIETY FOR THE INVESTIGATION OF THE UNEXPLAINED

GOVERNING BOARD

*President (elected for 5 years)
*First Vice-President
*Second Vice-President
*Treasurer
*Secretary
Board Member (elected for 1 year)
Board Member (elected for 1 year)
Board Member (elected for 1 year)
Board Member (elected for 1 year)

Hans Stefan Santesson
Edgar O. Schoenenberger
Ivan T. Sanderson
Allen V. Noe
Marion L. Fawcett
Walter J. McGraw
Thelma K. Yohe
Daniel F. Manning
Adolph L. Heuer, Jr.

*Trustees in accordance with the laws of the State of New Jersey.

EXECUTIVE BOARD

Director
Deputy Director
Executive Secretary
Assistant Director for Communications Media
Assistant Director for Science & Technology

Ivan T. Sanderson
Edgar O. Schoenenberger
Marion L. Fawcett
Walter J. McGraw
Allen V. Noe

SCIENTIFIC ADVISORY BOARD

- Dr. George A. Agogino – Chairman, Department of Anthropology, and Director, Paleo-Indian Institute, Eastern New Mexico University. (Archaeology)
- Dr. N. Burtshak-Abramovitch – Academician, Georgian Academy of Science, Palaeobiological Institute; University of Tblisi. (Palaeontology)
- Dr. Carl H. Delacato – Associate Director, Institutes for the Achievement of Human Potential, Philadelphia, (Mentology)
- Dr. W. C. Osman Hill – Dublin and London (Comparative Anatomy)
- Dr. J. Allen Hynek – Director, Lindheimer Astronomical Research Center, Northwestern University. (Astronomy)
- Dr. George C. Kennedy – Professor of Geology, Institute of Geophysics, U.C.L.A. (Geomorphology and Geophysics)
- Dr. Martin Kruskal – Program in Applied Mathematics, Princeton University. (Mathematics)
- Dr. Samuel B. McDowell – Professor of Biology, Rutgers University, Newark, New Jersey. (General Biology)
- Dr. Vladimir Markotic – Professor of Anthropology, Department of Archaeology, University of Alberta, Canada (Ethnosociology and Ethnology)
- Dr. Kirtley F. Mather – Professor of Geology, Emeritus, Harvard University. (Geology)
- Dr. John R. Napier – Unit of Primate Biology, Queen Elizabeth College, University of London. (Physical Anthropology)
- Dr. W. Ted Roth – President, Roth Research-Animal Care, Inc., Washington, D. C. (Ethology)
- Dr. Frank B. Salisbury – Head, Plant Science Department, College of Agriculture, Utah State University. (Phytochemistry)
- Dr. Berthold Eric Schwarz – Consultant (Brain-Wave Laboratory), Essex County Medical Center, Cedar Grove, New Jersey. (Mental Sciences)
- Dr. Roger W. Wescott – Professor and Chairman, Department of Anthropology, Drew University, Madison, New Jersey. (Cultural Anthropology and Linguistics)
- Dr. A. Joseph Wraight – Chief Geographer, U. S. Coast & Geodetic Survey. (Geography and Oceanography)
- Dr. Robert K. Zuck – Professor and Chairman, Department of Botany, Drew University, Madison, New Jersey. (Botany)

