

THE

PROBE

REPORT

**CAN A FLYING
SAUCER FLY ?**



P

THE PROBE REPORT: THE OFFICIAL PUBLICATION OF 'PROBE'. PUBLISHED QUARTERLY.

TERRY CHIVERS: PUBLICITY/TREASURER
IAN MRZYGLOD: EDITOR/BRITISH LIAISON/ARTWORK
DICK RYDER: METEOROLOGICAL RESEARCH
MIKE SEAGER: FOREIGN LIAISON
MISS. JULIE BLAKE: SECRETARIAL/DEPUTY TREASURER

EDITORIAL & MAGAZINE EXCHANGE ADDRESS: 16 MARIGOLD WALK, (0272) 666270
ASHTON,
BRISTOL. BS3 2PD.

FOREIGN LIAISON ADDRESS: 88 KINGS HEAD LANE, (0272) 646710
BEDMINSTER DOWN,
BRISTOL. BS13 7DD.

PUBLICITY ADDRESS: 8 EDEN GROVE,
WHITLEY,
MELKSHAM,
WILTS.

FOR URGENT CONTACT, RING EITHER OF THE ABOVE TWO NUMBERS, OR SHREWTON (0980) 620562.

oooooOooooo

oooooOoooooOoooooOoooooOooooo

oooooOooooo

SUBSCRIPTION RATES: £1.80 FOR FOUR ISSUES, POST FREE. (FOREIGN RATES ON REQUEST).
SINGLE ISSUE: 45p PLUS 15p POSTAGE & PACKING.

PLEASE MAKE ALL CHEQUES AND POSTAL ORDERS PAYABLE TO 'PROBE'

THE CONTENT OF 'THE PROBE REPORT' DOES NOT NECESSARILY REFLECT THE VIEWS AND
OPINIONS OF THE PROBE TEAM.

ALL ORIGINAL MATERIAL APPEARING IN 'THE PROBE REPORT' IS COPYRIGHT UNDER THE
COPYRIGHT ACTS. PERMISSION FOR USE IS OBTAINABLE FROM THE EDITOR.

COVER ILLUSTRATION: IAN MRZYGLOD

© PROBE, 1981.

PROBE

M.A.U.F.O.G.

16 Marigold Walk,
Ashton,
Bristol. BS3 2PD.

UFO Research Organisation

Tel, 0272 666270
646710

EDITORIAL COMMENT

MARCH 1981.

THWARTED!

When someone makes a report of an Unidentified Flying Object sighting to the authorities, i.e. the Police, Military Airports, and Civil Airports, that report is sent to the Ministry Of Defence, and there it stays for 30 years before it is made available to the general public. On January 1st this year, information from 1950, originally held under the Official Secrets Act, was released and made available for public viewing at the Public Record Office, Kew, Richmond, Surrey.

After writing off for, and receiving, application forms for Reader's Tickets, it then became apparent how difficult it could be to actually see this information. Firstly, you had to state your reasons for wanting a ticket, and secondly, you needed a letter from a 'person of recognised position (preferably one whose address can be obtained from a professional or similar directory)'. Meeting the relevant criteria, a team from PROBE set off in pursuit of UFO reports from 1950.

After obtaining Reader's Tickets and signing several sheets of paper including the visitor's book, we ascended the staircase of the huge building until we reached the reception. This was where we received our Teletracer Bleepers and seat numbers, and were eventually let loose in the Reference Room, where not one reference to UFOs could be found. When I asked the fellow at the enquiries desk about the 1950 reports, he told me there were none..... none released that is. Several reports were received during 1950 and should have been released this January, but the crafty lot have created a document called, 'UFO Reports: 1950-1954.' and this is scheduled for release in 1985!

There was one report available and that was of an 'airship' sighting over Sheerness in 1912; a seven page document containing a few decaying letters. I decided to look at this document and therefore dialed its number on the computer terminal. About thirty minutes later, when the document was ready for collection at the reception counter, my Teletracer Bleeper went off, flashing its little light and making a 'bleeping' noise. The photocopying of this report cost £1.40 (7 x 20p) plus 53p postage because it takes three days to process, and if anyone is interested in this document, please write for details.

So the whole day really proved unsuccessful, and I suppose we must wait until 1985 before anything worthwhile is released..... or will they do what I suspect will happen: The file will become, 'UFO Reports: 1950-1960', and then eventually 'UFO Reports: 1950-1970' and so on until the information is so old it becomes of little use. The file may always remain closed, classified as, 'UFO Reports: 1950 to current', in which case we will never see what is in them. Who knows? Whatever happens, they have certainly won the first battle and thwarted our first attempt to retrieve what should rightfully, I believe, be released.

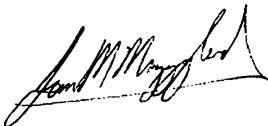

Ian Mrzyglod.
Editor.

NEWS ROUND UP

NEW RECRUIT.

On January 10th, Dick Ryder of Shrewton, Salisbury, Wiltshire, became the fifth member of PROBE's investigation team. The accurate weather and aircraft movement reports that he obtains for our investigations prove an invaluable asset, and helped in solving the Westbury Circles case.

TWO NETWORKS MEET.

In Birmingham, on February 7th, NUFON and MAUFOG met for the first time. The two UFO Group networks discussed future co-operation, and a working party to look at a 'code of practice' for UFO investigation was initiated. More meetings will be arranged for the future.

ANOTHER ONE BITES THE DUST.

Skywatch, one of the Swindon-based UFO research groups, has folded. Unfortunately, they are just one more statistic on the list of UFO groups that have collapsed over the years for one reason or another. This information was announced in January, but an official letter is intended to be circulated.

SETI.

HORIZON have a programme scheduled for screening on March 16th (and repeated the following Sunday), under the title "Hello Universe!" It tackles the subject of SETI, the Search for Extraterrestrial Intelligence.

ON THE AIR.

At 7.03 am, on Tuesday 20th January, Radio 1 D.J. Mike Read thanked PROBE for sending him a copy of our last magazine. Terry Chivers, PROBE's P.R. man, sent it to him because he has never hidden his interest in UFOs. In fact he has attended many skywatches in various parts of the country, in an effort to capture something on film. SEARCH (WEST) also did this a few weeks back and received similar thanks.

NEW UFO RESEARCH CENTRE.

A new centre has recently set up to provide facilities in various fields for UFO investigations. They already have a Forensic Analyst and an Assistant Photographic Analyst, and hope to appoint the Photographic Analyst, Medical Adviser and Astronomical Adviser in the very near future. For further details, contact Dept. of Forensic Analysis, 2 Morris Street, Birtley, Co. Durham.

CONTENTS.

CASE CLOSED.....	3
BOOK REVIEWS.....	4
TERRY'S SKYWATCH PAGE.....	7
SCI-FI SPOT (NEW BOOKS).....	8
INCIDENT AT DEVIZES.....	9
LOST: TWO UFOs.....	11
CAN A FLYING SAUCER FLY?.....	13
SIGNALS (LETTERS TO THE EDITOR).....	18
YE OLDE BOOK SALE.....	20

**CASE
CLOSED**

At present, we have no current cases which have been explained and none have been submitted by other groups for publishing, so for this issue's enquiry into solved UFO cases, the archives have to be delved into. Although the information is old and not original, it does serve to exemplify how a man-made phenomenon, in such circumstances, can puzzle so many observers.

Just after midnight on 8th April 1964, a large and very brilliant bluish-white light was spotted by military and civilian observers in Connecticut. Travelling at tremendous speed it suddenly changed to a red colour, and small objects detached themselves from the main body and trailed behind. Heading southerly, it was tracked and air control towers at airports and defence installations all the way to Long Island started to receive reports on it. Many calls were received and in every case, the details were similar.

Later on, reports were coming in from ships that were cruising about the Caribbean Sea, only the details began to vary. The object was described by some as flaming with a long tapered tail; others saw a flaming red or green ball followed by smaller objects. It was also reported as a light with a trail which resembled a peacock's tail, and a blue-white fireball with an orange tail. Observers on one vessel claimed the light radiating from the strange object was so intense that the deck and surrounding waters were flooded with light. Another ship stated that the main body exploded into fifteen fragments, which fell into formation and streaked out of sight. An oil tanker's captain witnessed an object that was round and blue-white on top, but flattened and red below, giving off sparks.

The Virgin Islands were the next place for reports to come in. People could see it and some were frightened by it. One native was convinced he had seen a big green globe which was followed by a flaming cigar-shaped object, while others insisted there were two lighted objects followed by a cluster of small ones which vanished into a cloud bank. The final sightings came from the coast of British Guiana where a red object cut a flaming trace across the sky and dropped from sight into the Atlantic Ocean.

The East Coast newspapers of the U.S.A. received the northernmost reports and these appeared the next day in print. One reporter made a note of the locations of the sightings and came up with the news that all were in a straight north-to-south line. He also discovered that all objects had been seen within a period of five minutes. It was assumed on the strength of the information, that all reports were of the same object. The reporter made some further calculations showing that the object must have been travelling at a speed of approximately 16,000 miles per hour. It had been absolutely silent and bore no resemblance to a meteor. All these points appeared in article form in the newspaper, and the readers were left to make their own minds up. This, they did, and the reporter was swamped with suggestions that the UFO was a mother ship sending out smaller scout discs, preparing to spy on military establishments. One astronomer insisted the UFO was nothing more than meteors.

By this time, Project Blue Book had received the details of the reports. The officer in charge contacted the National Space Surveillance Control Centre at Bedford, Massachusetts. Its project 'Spacetrack' was able to provide the correct solution to the mystery. Spacetrack technicians said that what the witnesses had seen and reported was the Soviet satellite, Sputnik II entering the earth's atmosphere and plunging to a fiery destruction. Sputnik II had been launched six and a half years earlier on 3rd November 1957. This information was swiftly made public.

**CASE
CLOSED**

A similar case which alerted the authorities began on 7th March 1960. Telephone calls flooded across the U.S.A. from about 8 pm that evening when reports began to come in from observers close to Lake Erie. A bright object had been seen traversing the night sky there, and further sightings were confirmed all the way south to Miami, Florida.

Project Blue Book contacted 'Spacetrack' and discovered that the witnesses had seen the satellite 'Discoverer VIII' re-entering the earth's atmosphere and burning up. This was another case which was given the label; 'Known'.

These two cases were, at the time they were reported, most definitely examples of Unidentified Flying Objects. To most people concerned, the objects were UFOs because they had never seen such phenomena before. Today, satellites are more common and therefore more eventually re-enter the earth's atmosphere and burn up in a brilliant array of colours. One only has to recall when SKYLAB came back near Australia, when it was captured on film. To an uninformed observer, that would certainly have been unidentified. These cases do demonstrate, however, that when the information is pieced together and examined closely, quite often a picture begins to form, and this can eventually lead to a satisfactory explanation

(Information obtained from: 'Is Someone Up There, Dale White. Scholastic Book Services, 1969.)

BOOKS

UFO...CONTACT FROM THE PLEIADES, Volume 1.

In short, this book is either the result of a very clever hoax, or the biggest breakthrough ever in the history of ufology. It presents the account of a Swiss farmer's remarkable experiences with visitors from the Pleiades star system. Why it could be the biggest breakthrough is because it displays extremely detailed photographs of flying saucers, with backgrounds of trees, fields, roads and houses. These photos are printed on 12 inch square, good quality paper and show five different types of craft as used by the Pleiadian Cosmonauts. The story started when Eduard "Billy" Meier set off to the countryside on his moped, armed with an Olympus 35 ECR camera because of some odd compulsion, and at 2.12 pm, on January 28th 1975, he saw his first silver disc-shaped craft circling in the sky. He took some photographs before the saucer landed, and a cosmonaut allegedly emerged and walked towards him. This was the beginning of an incredible account.



Of course, a story like this has a few points which need clearing up. One, is the content of the photos themselves; they show plenty of detail, and the large prints allow this to be enhanced, but the UFOs rarely seem to vary the angle. On pages 22/23, 25, and 27, the craft looks identical, even down to the reflecting areas. It could give the impression that it is the same shot superimposed on to the nearly-always grey sky. We also do not know who exactly carried out the computer analysis tests on the photos, or which scientists are still involved in testing the specimens of spacecraft metal. Personally, I would like to see some of the 8mm movie footage that is available, as this has been seen on Japanese TV. It certainly would help to substantiate this case. Whatever the outcome, this book is well worth owning, for it is destined to become a collector's piece. It costs \$24.95 plus \$1.50 shipping costs, from GENESIS 111 PUBLISHING, INC. P.O. BOX 32067, PHOENIX, ARIZONA 85064. U.S.A.

PHOTOGRAPHS OF THE UNKNOWN by Robert Rickard & Richard Kelly. 144 pages, 11½" x 8½". Price £7.95.

A superb book of photographs of things which have puzzled mankind for centuries. Among the topics covered are ghosts, the Yeti, stigmata and bleeding images, levitation, firewalking and UFOs. There are over 300 photographs, many in full colour, and some receiving their first publication, such as the UFO shots on pages 62 and 63, of an object emerging from the sea off the Canary Islands. This book has its emphasis on the photographs themselves and therefore the text has been kept to a bare minimum, mainly providing a numbering system and a brief background of the individual shots. Credits have been given at the back of the book, when known, along with a request for more photographs, presumably for a second book. This, I hope, is the case, for this book makes a splendid addition to the bookshelf; it will never become out of date, because I imagine this photographs will still be 'unknown' in years to come. Examples of this are the Poltergeist photos, where a girl is lifted from her bed and thrown through the air, and the disturbing shots of statues and paintings of Christ literally oozing blood from the head, hands and feet. A milestone in publishing, I hope this is the start of a lengthy series.

THE ENCYCLOPEDIA OF UFOS. Edited by Ronald D. Story. 440 pages, 11" x 7½", £12.95.

At first glance at the price, most people would defer from buying it, but the Encyclopedia has a lot to offer. Besides giving short biographies of people, who 'likewise in the opinion of the editors and our advisors, are generally regarded within the UFO field as the most notable personalities, leading UFO investigators, majoe thinkers, etc' the book features famous cases supported with colour photographs in some instances. The Encyclopedia is available in the U.S.A. at \$12.95, but that version is soft bound: this edition is hardbound in the best quality and does go towards explaining the vast price difference. A lot of the book's space is taken up with personal Position Statements from the featured personnel. These express their various theories, opinions on the subject and their involvement in it. I think perhaps that too much space was used in these statements, and more personnel could have been featured. Excellent as a reference book, but not a book for bedtime.

Both From

NEW ENGLISH LIBRARY



SPACE by Martin Ince. Sphere Science/Non-Fiction £1.50. Paperback.

The author is Technology Editor of 'Engineering Today', and explains his work as 'An overview, from the first Sputnik to the brave new world of the future'. This, his first book, is presented in a readable form that covers most aspects of space research to date, with an added bonus of a look into some of the projects that are presently in the planning stage. The main theme of this book is naturally satellites but is also packed with other information that will delight the reader with an interest in space research.

ALIEN INTELLIGENCE. by Stuart Holroyd. ABACUS (Sphere Books) Cosmology. 230 pages. Paperback. £2.50.

Looking at the cover and the title, one is lead to believe that this is another book on extraterrestrial beings. Not so. The author terms an 'alien intelligence' as anything that differs from 'human intelligence', so animals qualify in this respect. Part 1 of the book is dedicated to intelligent animal life, such as dolphins and chimps; intelligent robots and machines that appear to think for themselves; and 'spirit' intelligences of the dead. Part 3 of the book looks at UFOs and Space People, and this was the most interesting section of the book. I found it hard-going at first, but it improved later on. This work is illustrated with some fine photographs and sketches.

THE ROSWELL INCIDENT. by Charles Berlitz and William Moore. Granada Publishing Ltd. 176 pages. £5.95.

From the authors of the 'Philadelphia Experiment', this book concerns the alleged crash-landing of a spaceship in New Mexico in 1947. This story has recently received a great deal of publicity, as the national press have been featuring snippets from the book, and I dare say it will sell well. But once again, it is another work of speculation and rumours, with a distinct lack of hard, crucial facts. The story centres around some debris that was found on a ranch and a later press release stated that it was attributable to a crashed disc. The official view was that the debris came from a downed weather balloon. There are plenty of excerpts of text and memo's, including a photocopy of the 'Roswell Statement' that started the ball rolling. Also featured is a very poor quality photocopy of a photograph apparently showing an alien survivor from the wreckage being escorted by two U.S. military policemen, one of them appearing to hold some kind of breathing apparatus attached to the alien's head. The authors do not hide the fact that the quality and source of the photograph somewhat need to be desired, and that must go to their credit. Source material was obviously very scarce and some cleverly applied 'waffle' has been applied to make this a very readable and highly enjoyable book.

THE INTERRUPTED JOURNEY. by John G. Fuller. Souvenir Press Ltd. 340 pages, £6.95. Here is a complete book dedicated to one of the most famous UFO cases in history, the abduction of Betty and Barney Hill by aliens in a flying saucer. It recounts their experience which began on 19th September 1961 when they were returning home to Portsmouth, New Hampshire. An object which at first appeared like a very bright star eventually descended low enough for Barney to see figures at the windows of the strange craft. When they arrived in Portsmouth, it then became apparent that they had both lost two hours of their lives. The remarkable story only came to light through sessions of hypnotism, where they were individually questioned by Dr. Benjamin Simon, a Boston psychiatrist. Under hypnotism, Betty drew strange star maps showing 'trade routes' and 'space expeditions', and these were later likened to the system of stars with Zeta Reticuli 1 and 2 (a double star) being the focal point. This work was the result of intense study by Marjorie Fish. This version is an updated one with a foreword and epilogue by John Fuller, the latter containing an hypnotic session where the Hills were regressed in the presence of Dr. J. Allen Hynek. This book is seriously recommended.

EXTRATERRESTRIAL ENCOUNTER. by Chris Boyce. New English Library. Paperback. £1.35. A speculative work on a future encounter of beings so different from our own species. It is highly scientific and is illustrated with diagrams and pictures of futuristic Earth probes that will be self-maintaining and self-repairing, setting up bases in other star systems. Well researched, and I can only echo the author's thoughts as they appear in the conclusion when he refers to aliens far out in space: 'If we realise that we, like they, are a unique voice whispering in the dark a story which will never be heard again, then perhaps we will begin to see ourselves as precious, as all lifeforms surely are. Then perhaps we will begin to treat one another with the respect and compassion we so surely deserve. Then perhaps we will begin....'

PROBE MERCHANDISE

BACK ISSUES: PROBE Vol 1, No. 1; 40p plus 15p postage. (No. 2 out-of-print!)

The PROBE Report, Vol 1, No. 3; 40p plus 15p postage.

WARNINGS FROM FLYING FRIENDS. Hardback book by Arthur Shuttlewood. Illustrated, 266 pages. 70p plus 60p postage and packing.

UFOs - THE STARTLING FACTS. Glossy colour publication. 50p plus 15 postage.

UFO INFO: Vol 2, No. 2. 45p including postage.

All available from PROBE at the usual address.



TERRY'S SKYWATCH PAGE

A LOOK AT THE SKYWATCH SCENE

When Warminster was at its peak as a skywatching Mecca, a period from the mid 1960's to the very early 1970's, it attracted all sorts of people, ranging from serious researchers, interested parties, hoaxers, to religious cults. Pitching their tents all over the fields, they would all go about their individual tasks, which in some cases were quite interesting.....

One busy August Bank holiday, the fields were jam-packed with tents and skywatchers, and one particular spot of the field was occupied by a small group of people, sat in a circle, praying for the appearance of a being called 'Captain Fantastic' (or something like that), an extraterrestrial entity. They really believed in this person and continued praying for some time, with no results. In the meantime, some nearby skywatchers took sympathy on them and decided to make their dreams come true.

One skywatcher then disappeared to the copse at the top of the hill and then appeared minutes later as 'Captain Fantastic'. He was very tall, well over six feet, and wore a black Balaclava and his anorak hood pulled over his head. He was carrying a very long torch, and began his slow journey down from the copse. Meanwhile, the group were still sat praying unaware of what was going on around them, until one of them spotted 'Captain Fantastic' approaching.

They began to shout about how tall he was, at least seven feet tall, and they pointed to his 'laser gun' which was in fact his torch! Now you would expect anyone, at the sight of an alien walking out of the woods, to take fright and run; not this lot! They all got up and ran towards him calling his name. The sympathetic skywatcher saw them all coming and realised what could happen, so he turned round and ran in the opposite direction, followed by a very excited crowd. Neither the 'Captain' nor the crowd were seen again that night, and as far as I know, they haven't been back to try it again!

More recently, something really daft happened, this time involving me. Three carloads of skywatchers, (my car included), were leaving Cradle Hill for a skywatch at the nearby lake Shearwater, for a change of scenery. My car was the first in line, but half way down the hill I decided to take my coat off because I was uncomfortable. I stopped the car and got out, and began to remove my coat. Much to the dismay of my passengers, and to the amusement of the following cars, I had forgotten to apply my handbrake. By this time my car had started rolling down the hill, getting faster all the time, with me trying to hang on to the door and take my coat off at the same time. As I dropped my coat, I made a dive for the driver's seat and quickly wrenched the handbrake on. The car stopped inches from the bank, much to the delight of the passengers, and much to the disappointment of the following two cars. It's nice to have friends!

As of late, crowds and sightings are non-existent, but the crowds should pick up in the warmer weather. I hope so, because we've got some magazines to sell. Nevertheless we still carry on our monthly skywatches, the last of which was Saturday, February 14th. Two of us stood frozen stiff for two hours and more, watching an empty and cold sky. Things can only get better.

NEXT ISSUE: HOW TO BRING DOWN A UFO!

SCI-FI SPOT

NEW BOOKS REVIEWED BY PHIL HODGES.

THE MAGIC LABYRINTH: by Philip Jose Farmer.

PANTHER SCIENCE FICTION.

This is the fourth and final volume of the Riverworld series. Mark Twain, Herman Goering and Richard Burton are all resurrected in this highly imaginative story set on the mysterious Riverworld Planet. This book can only be truly appreciated if the first three volumes have previously been read, and in isolation it can be difficult to comprehend.

VOYAGE TO ARCTURUS: by David Lindsay.

SPHERE FANTASY.

A kind of Pilgrim's Progress by a central character called Maskuu who travels to the twin sun system of Arcturus and onto the planet Tormance. After a series of adventures, the story climaxes to an unexpected happening at Muspel. This science fantasy tale, first published in 1920, has stood the test of time well and can easily be compared to a number of the Jules Verne classics.

AFTER THE FALL: edited by Robert Sheckley.

SPHERE SCIENCE FICTION.

A series of fifteen short stories depicting alternative ways in which the world might end. "The Making of Revelation Part 1" by Philip Jose Farmer stands out as a particularly humorous and enjoyable tale. Further contributions by Harry Harrison, Roger Zelazny, Ian Watson, Bob Shaw etc. put this collection into the first division of the short story league.

BROTHER TO DEMONS, BROTHER TO GODS: by Jack Williamson.

SPHERE SCIENCE FICTION.

A highly readable book which involves the fortunes of two young Premen, Davey Dunahoo and Buglet, who find themselves with abnormal powers when faced with danger. These powers surface frequently when the Godlike race that rule the known Universe attempt to eliminate the Premen race by transporting them from Earth to the sterile planet of Andoranda V.

THE DRAWING OF THE DARK: by Tim Powers.

GRANADA SCIENCE FANTASY.

The main character in this tale is Brian Duffy, an Irish Mercenary Soldier. He is hired to be a bouncer at an Inn in Vienna where the famous Herzweston Beer is brewed. Vienna comes under siege by the Turks and it soon becomes apparent that the city has also become the focal point for a battle between the forces of good and evil, as represented by the Western and Eastern forces respectively. Duffy, although he does not know it, is to play a major part in the coming conflict, not only on the physical battlefield, but in the accompanying war of magic. This is a lengthy but well thought-out book which builds up to an exciting climax centered on the drawing of the dark.

THE DYING EARTH: by Jack Vance.

GRANADA SCIENCE FANTASY.

A science fantasy story set in Earth's future where science has been forgotten and magic predominates. If you like tales about Wizards, Witches, Monsters, etc, then this is the book for you.

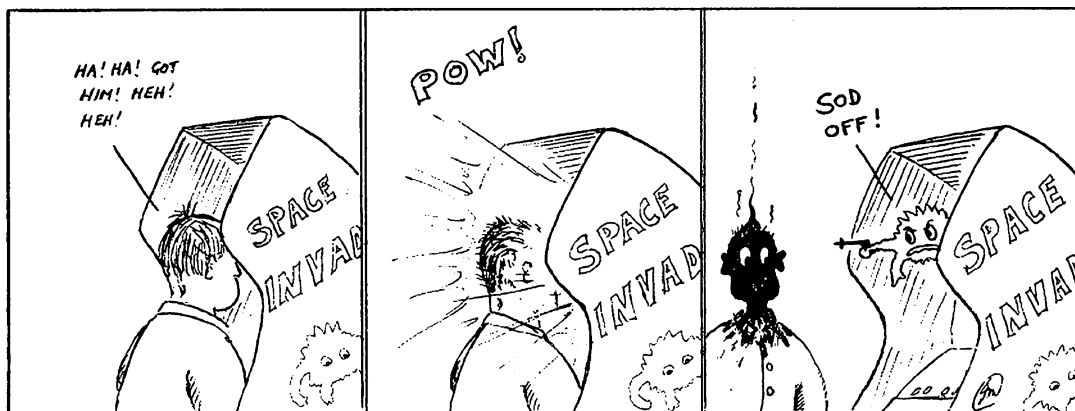

INCIDENT AT DEVIZES

by Terry Chivers & Mike Seager

Case ref: P3-80/H.

Introduction: This report first came to light via an article which appeared in the Bath and West Evening Chronicle, dated 24th September 1980, under the title, "Six Strange Objects In Wilts Sky." It read, "Were they UFOs or not? That was the question a Devizes couple were asking themselves today. Soldier Michael Box, 23, and his wife, Julie, 20, were mystified by their sightings from the back garden of their home at Drake's Avenue, off Pans Lane, at 6.30 am. 'I was in bed when Michael excitedly called me down to see these strange objects in the sky above the brow of a hill on the skyline,' said Julie. 'We could see six round objects, gleaming as brightly as stars, above the hilltop. Then suddenly, three went out like a light, and the other three disappeared behind the hill before re-appearing from another direction - and suddenly vanishing.'

Julie said, 'I was only wearing my nightdress at the time - I was absolutely shivering, and Michael, who is in the Queen's Lancashire Regiment at the School of Infantry at Warminster, was late for work. We were absolutely fascinated.' Julie said the objects were silhouetted against a clear blue sky and were visible for about 10 minutes. Later, she said, two helicopters appeared in the vicinity. 'But the objects we saw certainly were not helicopters, or flares.' "

Investigation: Acting on the newspaper article, we visited Michael and Julie Box on 4th October and conducted a lengthy interview with them, lasting well over three hours. Basically, they told us the same story, but did add a few more items of information and elaborated on others. For instance, according to their personal testimony, the duration of the sighting lasted between 21 and 30 minutes, not 10. The colour of the lights was described as golden, and Michael saw them more as triangular in shape. The estimated distance was given as $\frac{1}{2}$ to 1 mile at a level elevation, and the clear blue sky was once again emphasised.

An interesting point about this interview was the enthusiasm the couple showed for the subject. They even wanted to discuss the possibilities of joining PROBE as investigators for that area. Michael Box had previously believed in UFOs but neither had seen anything like this before, and now they wanted to become involved in the subject. We agreed to discuss this matter when all the members of PROBE could be present, and left it at that.

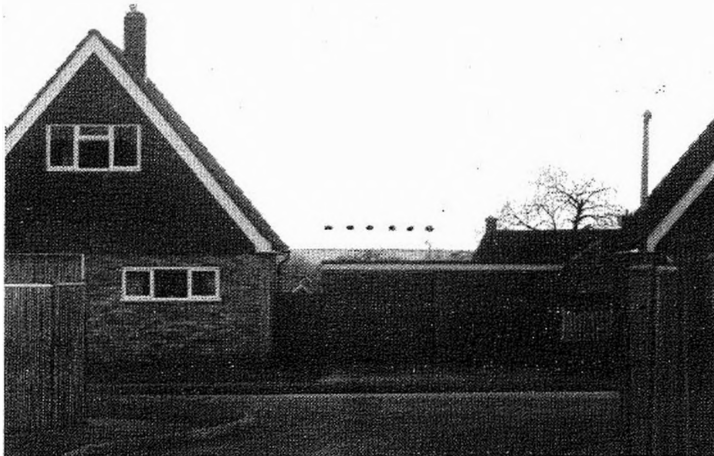

Photograph showing the position of the six lights as viewed from where the witnesses were standing.

On the 16th October, we wrote to RAF Lyneham, Chippenham, Wilts, asking for a weather report plus details of aircraft and helicopter activity about the time of the sighting. The Wiltshire Constabulary were also contacted to see if any reports of UFOs had reached them. The Chief Superintendent informed us that they had received none.

But the reply from RAF Lyneham proved to be very intriguing; they did confirm that a helicopter was in the area at that time, but it was the weather report that was puzzling. Their reply read: 'The weather at the time was cloudy with the cloud base at approximately 700 ft. and the visibility was 9 kilometers in slight rain.' This was a complete contradiction to the Box's reports, where they described a clear blue sky, so we wrote to them asking for more details, enclosing an SAE. This was not replied to so we wrote again with another SAE, but this time also asking about their interest in becoming involved with UFO investigation. Again, no reply.

In the meantime, a survey was carried out in the area where the UFOs allegedly appeared and vanished. The brow of the hill was at least two to three miles away and it stayed level beyond where we were standing, so the UFOs could not have 'dropped behind the hill'. Photographs were taken from this area, and Devizes was clearly visible down below. The results of this survey only added to our doubt already mounting up as time went on. A third letter with an SAE was sent just after Christmas and this received no reply, so we decided to draw conclusions from what evidence we had, and agreed to send one more letter only this time pointing out that they had cost us enough time and trouble by their lack of co-operation, so no more letters would be sent. It wasn't a rude letter in any way, but merely expressing our disappointment considering at one time they wanted to join PROBE.

Conclusion:

After taking everything into consideration, two conclusions were arrived at. The first was that the sighting was genuine and they somehow made mistakes in their testimony, and were later advised not to co-operate in our investigations. The sighting had been well publicised through the press, and senior officers were aware that we had interviewed the Boxes. The second conclusion, unfortunately, fits much better, and we tend to think this is the case: the whole story was a hoax. They achieved publicity from the press which is enough reason, in some cases, to stage such a story. The contradicting weather reports threw a great deal of doubt on the integrity of the couple's testimonies, as did the description of the UFOs disappearing behind the hill at a distance of no more than a mile. This was impossible from our findings, and unless we were vastly mistaken, meant that we were given a false story.

We still have not heard from Michael and Julie Box, nor do we expect to, but it would be interesting to find out just what motivates people to do this. We will not press them for any answers because they probably felt that the whole episode had gone too far and gotten out of hand. They may not have anticipated investigators turning up to enquire about the story and maybe feel guilty in some way for causing the whole thing. We will most likely never uncover any more information on this case, and until such time as we do, this case is labelled HOAX.

ADVERTISEMENTS:

NEW WORLDWIDE UFO DIRECTORY! Updated! Comprehensive! No serious Ufologist can afford to do without it. Names and addresses of UFO societies, groups, clubs and publications worldwide! Price £2 from:- UFO Network, 2 St. Ivian Crt, Colneyhatch Lane, London.N10.

WANTED. Any information on Astronaut UFO sightings - all costs reimbursed. Contact Keith Knight, 203 Liverpool Road, Ronkswood, Worcester, Worcs. Tel. Worcester 353063.

FILING CABINETS are needed by PROBE as the living-room floor is becoming crowded. Any condition. Please contact PROBE, 16 Marigold Walk, Ashton, Bristol. BS3 2PD., and state price.

LOST: TWO UFOS

by Ian Mrzyglod

Presented here is a classic, or so I thought, example of lens flare. The picture depicts Edwin (Buzz) Aldrin, of the famous Apollo 11 moonshot, setting up a banner of aluminium foil to face the sun in order to catch nuclei of atoms blowing from the solar wind. The foil was folded up after a couple of hours and brought back to earth for analysis in a Swiss laboratory. But in the top left-hand corner of this picture, at an elevation of about 25 degrees, are two light forms. Now when I first saw this photograph, it was trimmed so that Aldrin was only visible down to his knees and most of the Lunar Module was missing. Although the text was foreign, it was unmistakably describing the two UFOS hovering in the background, no doubt watching the Apollo mission with great interest. Another photograph was also presented in this book (which was either Spanish or Italian), which depicted the Lunar Rover vehicle and a similar light form just above a crater rim on the horizon. The photographs were treated, especially the first one, so that shadows were difficult to establish leaving a very misleading situation.

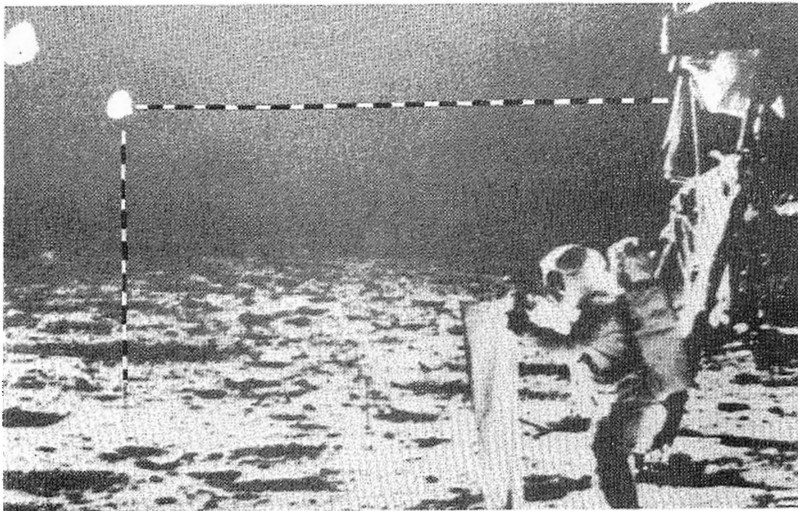

This photograph, which is a version that appeared in the book; 'First On The Moon', published by Michael Joseph Ltd, London, 1970, showed much more detail. (In fact, even more of the ground is visible in the book version). From this additional information, the direction of the sun could be established and I was satisfied that the two so-called UFOS were nothing more than lens flare. After all, it did seem strange that 'Buzz' Aldrin was more interested in his aluminium foil than the two unknown visitors.

I totally forgot the matter until recently a copy of the Science Museum booklet, 'EXPLORING, Man On The Moon', published by HMSO, caught my attention. For there was 'Buzz' still playing about with his aluminium foil with the Lunar Module in the background, only something was missing: the two 'UFOS' had gone. Thinking perhaps that the photograph had been cropped to eliminate the two lights, I decided to do some checking. Using the 'nearest' light as a marker, a line was placed on a horizontal plane until it reached the LM, and a vertical line was also added until it reached a convenient 'cross' on the photograph. (These crosses appear on several NASA photographs.)

A similar exercise was undertaken on the more recent photo, and where the two lines met, there was no light form. Although this reproduction may show a slight darkening on the left-hand section of the shot, the original, as published by HMSO, does not, so that can not explain the disappearance of the lights.

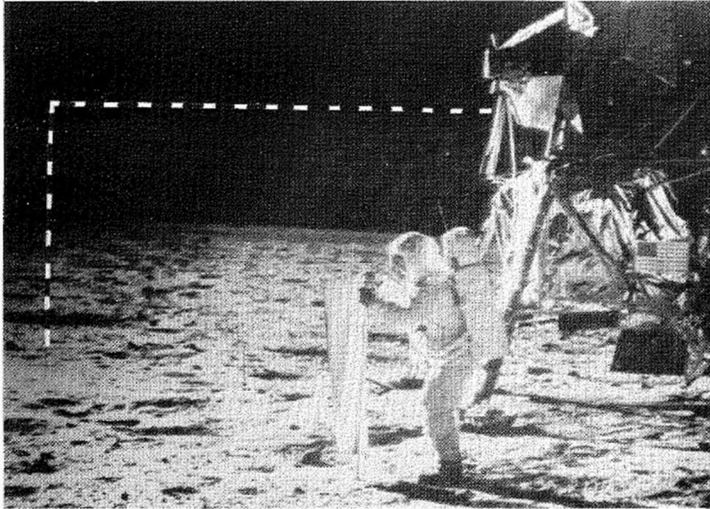

The only conclusions I can reach are thus:

a) That the photograph has been re-touched to eliminate the two 'blobs' of light. For what reasons, I have no idea, because it seemed obvious that they were not UFOs, just probably lens flare. But if they have been removed, does that throw a little element of doubt as to the origin of the lights? Certainly not in my mind, but I am curious of their(?) intentions.

b) That this is not the same photograph as the first one. It may be that two or more shots were taken in rapid succession so that no, or little, movement is detectable between the two. Personally, I don't think this is the case because the lens flare ought to have appeared on the second shot also.

It is a perplexing little puzzle that intrigues me and I would like to know the real story behind the photographs. It has occurred many times before in the past, when photographs have been tampered with, either to add UFOs to a picture or delete them, but I cannot see any reason to do so here. In doing so, I feel it may have caused a little controversy rather than prevented one.

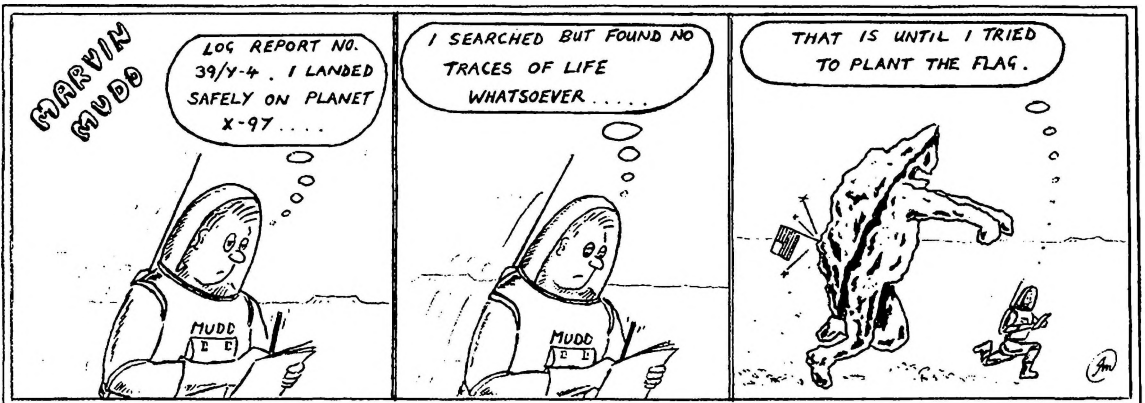

CAN A FLYING SAUCER FLY ?

Adapted From 'Zen & The Art Of Flying Saucer Maintenance.'

by Brian Smith.

The most comprehensive research ever carried out with respect to UFOs was probably that administered by the Condon committee. A body of scientists set up in the 1960s to investigate the hundreds of reported sightings of strange objects in the sky. If sheer brain power is anything by which to judge, then UFOs should have been 'done away with' once and for all. Unfortunately the committee doesn't seem to have met with overwhelming success, for undeniably UFOs are still with us. The body of scientists did, it is true, produce a report, (1) but in the main it is regarded, by most ufologists at any rate, as totally biased and inconclusive. The scientist who becomes involved with ufology treads an extremely precarious path, which for reasons too complex to discuss in this short treatise has in more than one case led to a loss of credibility. In the case of J. Allen Hynek, (2) astronomical consultant to the earlier American 'probe into UFOs', Project 'Blue Book', a rather remarkable turnabout occurred. For Hynek, initially rather anti-UFO, later joined the ranks of the 'watchers of the skies', set up his own 'Centre for UFO Studies' and is at present regarded as one of ufology's heroes.

Flying saucers are of course a particular aspect of ufology, even among ufologists the name is carefully avoided. However, 'flying saucer' has become a household phrase taken to mean a spaceship 'manned' by extraterrestrial visitors. It ought to be admitted (but rarely is) that this is where the real UFO debate focuses, for whilst most scientists are prepared to accept that there may be odd occurrences of unusual phenomena, they are not prepared to accept that the earth is being visited by races from space. There is, however, an interesting paradox here. In the twilight zone where our frame of reference of the physical Universe becomes, to say the least, nebulous, all men are susceptible to flights of the imagination, scientists and saucerers alike.

Ironically it is science and not ufology that gets the prize for fantasy. For the highly speculative nature of the space sciences virtually predicts the existence of alien races, incredible spaceships and flights of immense distance. In scientific circles, fanciful imaginings are catered for by a mind reach process, already popularised by the title 'spaceships of the mind'. Spaceships of the mind has a considerable body of subscribers, a sort of esoteric circle, their mind-boggling concepts are usually confined to the pages of professional journals. Nevertheless the motivation for developing the ideas seems to be remarkably similar to that of the less informed, but equally enthusiastic, saucerers and probably springs from the same psychological need. We all have to come to terms with the unknown and this will be largely a matter of making choice; for as Seng Ts'an informs us:-
"When the deep meaning of the way is not understood; peace of mind is disturbed to no purpose."

Indeed, Zen claims to point a paradoxical way, at once abstract and personal, that is markedly different from more conventional philosophies. Judging from the enormous amount that has been written concerning flying saucers and their more sophisticated relatives, spaceships of the mind, one recognises a certain parallel with the following lines of Zen verse:-
"When one looks at it, one cannot see it; when one listens for it, one cannot hear it; however, when one uses it, it is inexhaustible."

Evolution and the Extraterrestrial Intelligence Hypothesis.

The rules of science are clear, or so the 'ufonauts' and 'saucerers' are told, on one point at least. It is up to the proponents of an hypothesis to discharge the burden of proof. The hypothesis with supporting evidence is examined by the proponent's peers, who do their best to fault it. If they cannot, and the hypothesis is sound, then with further evidence, preferably obtained by experiment, the hypothesis becomes a theory and the theory, in time, becomes an orthodoxy.

And what of the theory of evolution; was there ever adequate supporting evidence for the original hypothesis? No.
Is it proven? No. (3).
Is it an orthodoxy? Yes.

So science tells us that man, the intelligent being, resulted from random mutations preserved by natural selection. Now we should indeed be wary here, for the theory of evolution provides considerable underpinning for many other branches of learning; and from it follows the logical corollary that life will evolve where conditions are suitable. The new 'science' of exobiology, which as far as the author is able to ascertain, has yet to show that its subject matter exists at all; leads us on to the 'assumption of mediocrity'. (The hypothesis that the human race is an average race, on an average planet orbiting an average star.) (4). So here we are, from humble beginnings an hypothesis unsupported by positive evidence and not susceptible to experiment, has made the possibility of life elsewhere in the galaxy and beyond, such a certainty that the majority of scientists would support this view.

Science, the Devil, Green Men and Philosophy.

To a certain body of clergymen UFOs are quite clearly manifestations of evil, for many UFO buffs they are spaceships manned by little green men; and that science has, at least, accepted the physical reality of UFOs can hardly be doubted, judging from the wealth of scientific reports explaining UFOs in physical terms. Despite the assertions of C. G. Jung, (5) UFOs have emerged as optical illusions due to atmospheric refraction, (6) plasma bodies, (7) and of course misidentifications of well known objects, eg. Venus, aeroplanes, weather balloons etc. However, the nagging doubt remains: have we overlooked something? Can we be sure? Is our model of the physical universe inaccurate or incomplete? Perhaps there is nothing like a liberal dose of uncertainty for making one humble. Voltaire assures us, "Doubt is not a very agreeable status, but certainty is a ridiculous one." "Do not despise this man because his philosophy differs from your own, but listen to what he says, for there may be much that can be adapted to your way."

In view of the highly conjectural nature of much of what passes as modern science, it seems regrettable that the concept of flying saucers as spaceships is now shunned by all, save those regarded as the 'idiot fringe'. Even the science fiction writers regard ufology as 'bad for the image' and flying saucers and 'saucerers' are discussed only in a derogatory manner for the amusement of the 'enlightened' readership. (8). As the 'extraterrestrial intelligence UFO hypothesis' has, to a large extent, been aided and abetted by scientific conjecture and speculation, eg, through the 'assumption of mediocrity' etc, let us confine our enquiry to this aspect of ufology just once more. This must be based upon extrapolations of existing technology, and without recourse to any scientific principle as yet unknown. Although of course, we cannot rule out the possibility that intelligent beings from elsewhere, (if indeed they exist), have access to principles as yet unknown to us. However, the guiding principle here will be; what we can do, so will they be able to do.

Ships for the Stars.

In order to visit the planetary system of some other star, (assuming such a planetary system exists), the following types of vehicles, covering four stages of flight, would seem to be necessary.

- 1) Launch vehicles, capable of lifting into orbit the requisite hardware, from which the other vehicles would be assembled.
- 2) The interstellar vehicle or star-ship; or possibly a fleet of such vehicles, (depending on distance contemplated, speed of voyage etc.)
- 3) Planetary excursion vehicles, capable of being launched from and returning to the star-ship. They would remain in orbit around the planet to be investigated and would be capable of carrying planetary landing vehicles.
- 4) Planetary landing vehicles, able to enter the atmosphere (when encountered) of a favourable planet, land and ascend from the planet's surface to rendezvous with the planetary excursion vehicle.

It is the 4th category vehicle, the Planetary Landing Vehicle, which we will examine in close detail, in order to try and answer the question;

Can a Flying Saucer Fly?

N.A.S.A. predict entry velocities ranging from 25,000 to 60,000 ft per second, (9). At speeds above 40,000 ft per sec., ballistic entry becomes less attractive owing to heat problems; and lifting body vehicles employing hypersonic lift/drag ratios are anticipated. Such a vehicle would be incapable of hovering flight, (important when the planet's surface is relatively unknown), hence it becomes desirable to hold the entry velocity of the planetary lander down to around 35,000 ft per sec. The characteristic 'flying saucer' shape, the underside of which can be utilised as an ablation shield makes it admirable for ballistic entry. Many UFO reports, describing solid objects, tell of a vehicle 10 metres (30 ft) or so in diameter, and about 3 metres (10 ft) in height. The planetary landing vehicle must satisfy the following criteria:-

- 1) It must be as compact as possible, and capable of being carried by the planetary excursion vehicle.
- 2) It must be capable of entering the atmosphere of the planet to be investigated, and capable of hovering flight, until a suitable landing site is located. (Recall the Lunar Module.)
- 3) In order to return to its 'mothership', the lander must have single stage-to-orbit capability, ie, it must lift off from the planet's surface and be able to achieve orbit velocity.

Design Criteria:

The orbital or required injection velocity is obtained from the equation;

$$V_c = \sqrt{\frac{g \cdot R_p^2}{r}} \quad (1)$$

Where V_c is the circular orbit velocity; g is the acceleration due to gravity at the planet's surface; R_p is the radius of the planet; r is the radius of the orbit from the planet's centre.

For an orbital altitude of 200 miles, the required circular velocity is, from equation (1); 25,450 feet per second.

Also Konstantin Tsiolkovsky's famous rocket equation states; $V_c = V_e \log_e R$ (2) Where V_c is the characteristic velocity (identical with orbital velocity.); V_e is the exhaust gas velocity; R is the vehicle mass ratio; $\frac{M}{M_b} = \frac{\text{Mass at Lift Off}}{\text{Mass at all burned}}$ (3)

The corresponding propellant mass ratio is;

$$\frac{M_p}{M} = 1 - \frac{M_b}{M} \quad (4)$$

With present-day chemical rockets where the exhaust gas velocity is a serious limiting factor, the only means of obtaining the required velocity (V_c) is by increasing the vehicle mass ratio. This is accomplished by using the step or multi-stage rocket. Equation (2) then becomes;

$$\begin{aligned} V_c &= V_e \log_e R_1 + \log_e R_2 + \log_e R_3, \\ &= V_c = V_e \log_e (R_1 R_2 R_3) \end{aligned}$$

The planetary landing vehicle we are considering here need not recognise any such limitation. The most suitable power plant for the PL is probably a gas-cored nuclear reactor, using hydrogen as a propellant. This unit has the advantage of high thrust/acceleration, coupled with high specific impulse, (and hence exhaust gas velocity) allowing an enormous reduction in the vehicle mass ratio.

Fig. 1 shows the configuration of such a power plant. The operating temperature of the gas-cored nuclear reactor far exceeds that of conventional rocket motors, and makes previously undreamt of exhaust gas velocities possible. The exhaust gas velocity obtainable with a given propellant temperature is derived from the equation;

$$V_e = K \sqrt{\frac{Q_0}{MW}} \quad \text{miles per sec.} \quad (5)$$

Where V_e is the exhaust gas velocity; K is the constant, (taken as .2); T_0 is the reactor temperature in degrees K; MW is the molecular weight of the exhaust gas.

Assuming our reactor can raise the propellant to the absolute maximum temperature of $22,500^\circ$ K, then the exhaust gas velocity will be;

$$V_e = .2 \sqrt{\frac{22,500}{2}} = 21.213 \text{ miles per sec, or approx. } 112,000 \text{ ft per sec.}$$

The specific impulse (Isp) is derived from the expression;

$$\frac{V_e}{g} = \frac{112,000}{32.2} = I_{sp} = 3,478 \text{ sec.}$$

Now if the orbital velocity is to be 25,450 ft per sec, then from equation ((2));

$$\frac{M}{M_b} = \text{antilog}_e \frac{V_c}{V_e} = \text{alog}_e \frac{25,450}{112,000} = 1.25.$$

So the vehicle mass ratio is 1.25. Let us assume that the total weight of the vehicle at launch is 25 tons, then;

$$M_b = \frac{25}{1.25} = 20.00 \text{ tons.}$$

We do not need equation ((4)) to see that the corresponding propellant mass ratio will be .2, and that the total weight of propellant carried by the spacecraft is to be only 5 tons. (11,200 lbs.) (These calculations neglect the propellant required by the vehicle for descent (retro) and hover.) As we require the propellant which will hold the most energy per unit mass, the propellant is hydrogen. Liquid hydrogen has a density of 4.4 lbs per cubic foot, and will require a storage volume of 2,545 cubic feet. The rocket motor must be capable of delivering a continuous thrust of 1.25 above $g = 1.25 \times 25$, or 31.25 tons; 70,000 lbs thrust. Propellant consumption per sec will then be;

$$\frac{\text{Thrust}}{I_{sp}} = \frac{70,000}{3,478} = 20.126 \text{ lbs per sec.}$$

Fig. 2 shows the layout and approximate dimensions of such a vehicle. Table 1 gives the specification.

Conclusion.

The concept of flying saucers has been, hopefully, 'maintained' using a little Zen philosophy, a lot of speculative science, and some order of magnitude calculations. The author feels that as flying saucers have held their own as 'anti-science' for thirty years or so, it may not be a bad idea to make them feasible. (Albeit on the borderline of feasibility.) Who knows, perhaps the science fiction authors may now take heart, and find that the saucer-shaped UFO has at least some respectability.

For;

To set up what you like against what you dislike-
That is the disease of the mind:
The way is perfect like unto vast space,
With nothing wanting nothing superfluous.....

(Seng Ts'an)

REFERENCES:

- 1) Scientific Study of Unidentified Flying Objects. (Edited by E. U. Condon).
The New York Times 1969.
- 2) J. A. Hynek. The UFO Experience, Henry Regnery, Chicago, 1972. also:-
The Hynek UFO Report. Sphere Books Ltd, London, 1978.
- 3) Norman Macbeth. Darwin Retried, The Garnstone Press Ltd, 1974.
- 4) I. S. Shklovskii & C. Sagan. Intelligent Life in the Universe, Pan Books, 1977.
- 5) C. G. Jung. Flying Saucers, A Modern Myth of Things Seen in the Sky, Routledge,
1959.
- 6) Donald H. Menzel & Lyle B. Boyd. The World of Flying Saucers, Doubleday, 1963.
- 7) P. J. Klass. UFOs Identified, Random House, 1968.
- 8) Arthur C. Clarke. Voices From the Sky. Mayflower Books, 1969, pp 166/167.
- 9) Advances in the Astronautical Sciences, Vols 13 & 15. The American Astronautical
Society, 1966.

The Gas Cored Nuclear Reactor (Nuclear Light Bulb) Isp. 1,100 to 5,000 (SEC).

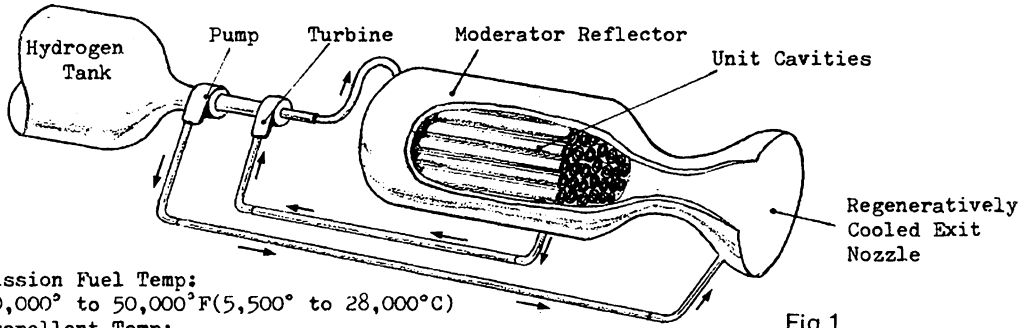

Fission Fuel Temp:
 10,000° to 50,000°F (5,500° to 28,000°C)
 Propellant Temp:
 8,000° to 40,000°F (4,500° to 22,200°C)

Fig 1

TABLE 1.	Specification
Overall diameter;	38 ft.
Height;	14 ft.
Total weight of machine unladen;	19 tons.
Total weight of machine at lift off;	25 tons.
Power plant; Gas cored nuclear reactor (Hydrogen propellant).	
Operating temperature;	25,500°K.
Exhaust gas velocity;	112,000 ft per sec.
Max velocity; (Circular orbit velocity)	25,500 ft per sec.
Fuel pump delivery rate;	20.126 lbs per sec.

The Planetary Landing Vehicle (Flying Saucer).

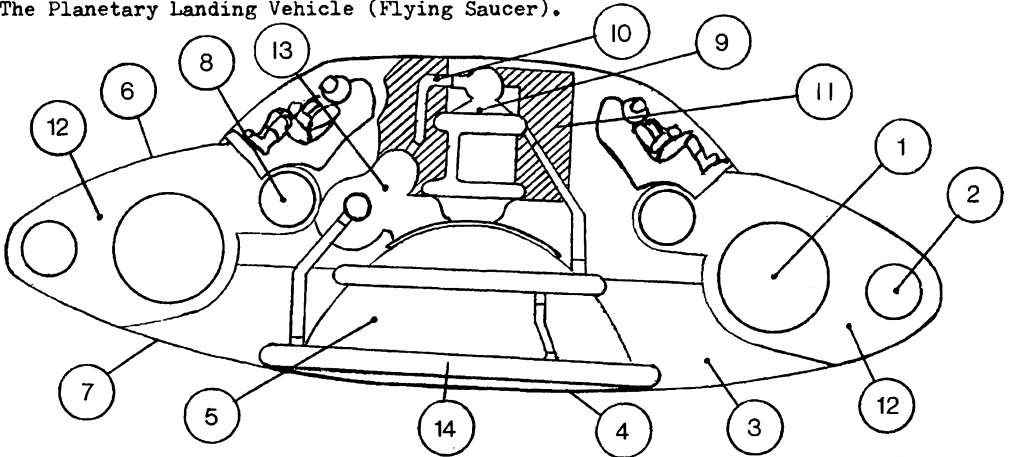

Fig 2

(1) Main toroidal propellant tank - 2,100 cubic feet capacity. (2) Secondary toroidal propellant tank - 750 cubic feet capacity. (3) Refrigeration unit for cryostat chamber. (4) Secondary ablation shield covering exhaust orifice. (5) Gimbaled thrust nozzle. (6) Titanium outer skin. (7) Outer shell faced with ablative material. (8) Auxilliary propellant tank - 260 cubic feet capacity. (9) Gas cored nuclear reactor. (10) Propellant delivery (main). (11) Biological shield. (12) Cryostat chamber. (13) Turbo pump. (14) Regenerative cooling ring.

SIGNALS

LETTERS TO THE EDITOR

Dear Ian,

May I congratulate you and your team on another excellently produced 'PROBE Report'. It is difficult to see how the 'report' could be improved. The only thing I could think of was to have printed headings on all features. This would give better visual presentation. At present you have headings for 'CASE CLOSED' and 'Terry's Skywatch Page' but other headings remain typed, so why not extend this idea throughout? One more thing worth a mention is the poor coverage you gave to the Exhibition in Report No. 3. Having attended the event, in my considered opinion it was well organised and attracted quite a lot of attention, particularly from the press etc. I would have thought that such an event would have warranted a more detailed account. To end on a lighthearted note, could I just say that I think 'Terry's Skywatch Page' is both humorous and real. The sketch of Terry bears a good resemblance to the great man himself, and now that we know that Terry did NOT shoot J. R. would you please ask him if he ever thought about entering politics as I think he would make a good Prime Minister. Perhaps we might have compulsive skywatching for ALL. Best wishes,

Keith Knight, Worcester, Worcs.

(As you can see, your suggestion for printed headings has been adopted, and as for your last suggestion?..... Ed)

Dear Ian,

I would like to, if I may, pass some comments regarding Vol 1, No. 3 issue of your magazine 'The PROBE Report'. I must congratulate you on the excellent production standard you have attained via your glossy paper format - may your cash never cease to flow! Also your own artistic qualities are very evident with your monochrome moon scape front cover, cartoons and Marvin Mudd, Britain's answer to Hal Crawford - I wonder? With respect, I found Keith Knight's article 'Astronaut Sightings' very naive in content and presentation, perhaps Keith was unable to obtain enough source material to present a better viewpoint and this I understand. The writings of Wilson and Stringfield leave a lot to be desired, as do small items in various magazines and books which have never been correctly researched. I advise Keith to obtain the latest issue of FUFOR's magazine 'UFO INSIGHT', Vol 2 No 1, issue 7. On pages 14 to 16 can be found an excellent article by C. D. Allen, entitled 'Have Astronauts Seen Alien Space-ships'. Finally on this point, Keith should be thanked for at least writing an article, which is more than too many never do! On the Westbury Circles case, I feel your group missed a good opportunity to publish this entire case as a 'case history', and in doing so would have set the facts straight, unlike 'NOW!' magazine's feeble attempt. A concise published case report would have been most welcome in UFO circles concerning the circles. The ramblings of Shuttlewood would have been better left unpublished, and Terry's contribution, grappling with skywatching was an interesting read. In closing may I say that I would like to see more original contributions in PROBE Report from people who are active in the subject today. This, plus subscription support, should instill a promising future for your magazine. Regards,

David Rees. Editor MAPIT SKYWATCH, Stockport, Cheshire.

(I too would like more original contributions from people active in the field today, but MAPIT SKYWATCH seems to monopolise most of it! And concerning the Westbury Circles case, 'NOW!' were sent a report and letter of the true facts but nothing ever came of it. But more important, our conclusions were only opinions, and not positive identifications of the cause of the circles. We could be very wrong, so we were reluctant to publish a case history of the event just for that reason. Ed)

Dear Ian,

I was very interested to read about your investigation into the Westbury 'UFO Nests' and the fact that weather had been eliminated from your enquiries. However, I have witnessed, in summer, very localised whirlwinds in otherwise calm conditions. These seem to describe a spiral pattern. I feel it is possible that one of these, moving across the standing crops from place to place, might have been responsible. Nevertheless, the prevailing weather conditions at the time could yet rule out this suggestion.

W. H. Chester, Hounslow.

(You had only just read Vol 1, No. 2, when you wrote this letter, and as you saw in No. 3, we reversed our decision on the weather when correct details were uncovered, and opted for the funnel-cloud theory. Ed)

ON THE ROD JAMES ENTITY CASE;

Dear sir,

I have just read your 'PROBE Report' No. 3, and one item in particular, 'Early Morning Entity in Trowbridge', interested me greatly. In the past I have been involved in several cases which have included this type of phenomena and I wondered if you would be interested in hearing about some of my observations. The experience related by Mr. James leads me to believe that he may have witnessed some kind of projected image, either physically visual or projected through his own mind. I favour the second possibility as the communication was remembered almost in its entirety even though the visual image had no mouth. Obviously, the message was conveyed by telepathic means. This may not mean that the message was intended for Mr. James; he may well have 'tuned in' unwittingly to a communication intended for someone else or even a group of people, perhaps it was intended for anyone who was capable of receiving such a message. A person who is receptive could be most vulnerable at the time of sleeping/awakening, as sleep is an altered state of consciousness, the transition time might be delicate under certain conditions. I think it unlikely that Mr. James would have been singled out for such a message, which let's face it, isn't exactly new. Collectively, Mr. James' experiences lead me to believe that he has a receptive mind and could develop it further if he wished. I mean, of course, in a psychic way, which brings me to another possible explanation. We often hear of people who have dreams that come true; could this be the case with Mr. James' experience, and how could we interpret it? To me, the picture he drew symbolises an Egyptian Mummy, and to me that might mean death. The message could also mean the same, i.e. the death of the Earth. Perhaps others could put different interpretations to the account, but in any event I believe that Mr. James had a genuine experience and think that the key to finding the purpose is just a matter of interpretation. Yours sincerely,

Charles Hardin, West Bromwich, Staffs.

Dear Mr. Mrzyglod,

I am interested in your report on an 'entity' at Trowbridge. This would appear to be a fairly typical hypnogogic hallucination, although the 'contactee' type message is unusual in this type of case. Unfortunately your report is skimpy on background information on Rod James, and without this it is difficult to form any very clear impression of how this experience fits into any possible pattern of events. I think it is significant, for instance that Mr. James is sufficiently motivated by an interest in UFOs to go to Cradle Hill late at night. The 'message' is so similar to some others in the literature that I think you would possibly be unwise to rule out all possibility that a rather different type of event has been coloured in its reporting by the percipient's background and interests. Interesting to see that Arthur Shuttlewood is still writing, in his inimitable style. I think with Shuttlewood more than with any other ufological writer, form is more important than content! Still, he is quite a character. Best wishes,

John Rimmer. Editor MAGONIA, New Malden, Surrey.

Dear Ian,

Regarding the Mr. James of Trowbridge case, the incident appears, from the details given, to be a product of his subconscious mind, though probably not conscious hoax. Did you ask him if he is very concerned about the future of Earth, ecology, etc? It sounds like the 'we-shall-all-be-destroyed-unless-we-mend-our-ways' syndrome. Another thought: since he has read many books on UFology, and no doubt a proportion of them on this theme, it is odd that he didn't know the name of a suitable rift. And why a rift, instead of our old friend the San Andreas Fault? And have you asked a geologist if the remarks re explosions liquifying then solidifying could be a valid theory? It does not sound too convincing. You probably did cover these points and simply hadn't space to feature them. Sorry! Blessed be,

Magda Graham. Editor OCCULT WORLD, Ipswich, Suffolk.

(These comments and suggestions are appreciated, because I did point out in the last issue that PROBE were totally new to this type of incident. I suggested the San Andreas Fault to Mr. James at the time but he was insistant the rift was a name he

had never heard before. As for your last comment, Magda, you flatter me! These avenues of enquiry had been overlooked, but are now in operation. Incidentally, any suggestions as to how I ask a geologist if flying saucers from outer space can repair structural faults in the Earth's crust? Ed)

Be Olde Book Sale

When the Brighton-based NUFOR folded last September, the files and books remained gathering dust until we managed to make a trip to Brighton and rescue what was left. After buying up the entire book library, we added to our own library and are now offering the surplus books for sale. They are all paperbacks except one, and it must be remembered that they are secondhand and some are stamped with 'NUFOR' on the inside. Postage costs are 20p per book up to three books, and then 10p per book afterwards. Offers subject to availability, with cash refunds when necessary.

IN SEARCH OF ANCIENT GODS (VON DANIKEN) HDBK.	50p
THE SPACESHIPS OF EZEKIEL (BLUMRICH) EXCELLENT COND.	50p
UFO: FLYING SAUCERS OVER BRITAIN (CHAPMAN) " "	50p
ALIENS FROM SPACE (KEYHOE)	35p
GODS & SPACEMEN IN THE ANCIENT EAST (DRAKE)	35p
UFO'S FROM BEHIND THE IRON CURTAIN (HOBANA & WEVERBERGH)	35p
UFO'S: THE PSYCHIC SOLUTION (VALLEE)	35p
BEYOND THE TIME BARRIER (TOMAS)	35p
GODS & SPACEMEN IN ANCIENT ISRAEL (DRAKE)	30p
COLONY: EARTH (MOONEY)	30p
THE SPACESHIPS OF EZEKIEL (BLUMRICH) 2 COPIES.	30p
VOYAGE TO ATLANTIS (MAVOR)	30p
RETURN TO THE STARS (VON DANIKEN)	30p
STRANGERS FROM THE SKIES (STEIGER)	25p
FLYING SAUCERS ARE HOSTILE (STEIGER & WHRITENOUR)	25p
OPERATION EARTH (LE POER TRENCH)	25p
CHARIOTS OF THE GODS (VON DANIKEN)	25p
RETURN TO THE STARS (VON DANIKEN) 2 COPIES.	25p
THE GOLD OF THE GODS (VON DANIKEN) COVER MARKED.	25p
THE BERMUDA TRIANGLE (BERLITZ)	25p
SECRETPLACES OF THE LION (WILLIAMSON)	25p
THE DRAGON & THE DISC (HOLIDAY)	25p

From: PROBE, 16 Marigold Walk, Ashton, Bristol. BS3 2PD.

ADVERTISEMENTS:

WANTED. 'Warminster Mystery' by Arthur Shuttlewood, either hardback or paperback edition. Please state price to 'PROBE', 16 Marigold Walk, Ashton, Bristol. BS3 2PD.

SKYWATCH is full of national and international UFO news, sightings, readers' letters, articles, adverts. Contributions/paper clippings always welcome on any UFO-related subject. Full credit given. Membership and subscription to MAPIT-SKYWATCH is £3.00 (six issues). Single issues 35p incl. p & p. Back issues available. Write to David Rees, Mapit-Skywatch, 92 Hillcrest Road, Offerton, Stockport, Cheshire. SK2 5SE.

OCCULT WORLD. The independent magazine bridging the gap between the various Occult traditions. Stimulating and controversial, an open forum for all Occult points of view and dedicated to Pagan Co-operation. Quarterly 30p post paid, from 303 Cauldwell Hall Road, Ipswich, Suffolk. IP4 5AJ.

SEARCH (WEST) GROUP MAGAZINE. Quarterly UFO magazine full of articles, news, photos, press clippings and information. £2.20 for four issues post paid, apply to SEARCH (WEST), 120 Savernake Avenue, Melksham, Wilts. SN12 7HQ.

MAGIC SAUCER. The UFO magazine for children and the young at heart, £2.45 per year (six issues) or 41p per copy, post paid. 8 Ely Close, Habberley Estate, Kidderminster, Worcs.

PROBE IS PLEASED TO STATE THAT AT THIS PRESENT MOMENT, WE ARE EXCHANGING WITH THE FOLLOWING PUBLICATIONS:

AWARENESS, 48, Crown Road, Wheatley, Oxon.
BUFORA JOURNAL, 95, Taunton Road, London. SEL2 8PA.
EARTHLINK, 16, Raydons Road, Dagenham, Essex. RM 9 5JR.
FORESIGHT, 29, Beaufort Avenue, Hodge Hill, Birmingham. B34 6AD.
JOURNAL-TAP, 95, Taunton Road, London. SEL2 8PA.
LANTERN, 3, Dunwich Way, Lowestoft. NR32 4RZ.
MAGIC SAUCER, 8, Ely Close, Habberley Estate, Kidderminster, Worcs. DY11 6EJ.
MAGONIA, 64, Alric Avenue, New Malden, Surrey. KT3 4JW.
MERSEY NEWS, 133, Hinkley Road, Islands Brow, St. Helens, Merseyside.
NORTHERN UFO NEWS/NORTHERN UFOLOGY, 8, Whitethroat Walk, Birchwood, Warrington, Cheshire.
NUFOIS NEWS/UFO RESEARCH REVIEW, 443, Meadow Lane, Nottingham. NG2 3GB.
OCCULT WORLD, 303, Cauldwell Hall Road, Ipswich, Suffolk. IP4 5AJ.
PEGASUS, 149, Mytchett Road, Mytchett, Camberley, Surrey.
QUEST, 160, Courtney Road, Kingswood, Bristol. BS15 2RN.
SCOPE, 77, Allbrook Hill, Eastleigh, Hants.
SEARCH (WEST) GROUP MAGAZINE, 120, Savernake Avenue, Melksham, Wiltshire. SN12 7HQ.
MAPIT SKYWATCH, 92, Hillcrest Road, Offerton, Stockport, Cheshire. SK2 5SE.
UFO NEWS BULLETIN, 118, Westerleigh Road, Downend, Bristol. BS16 6UX.
UFOS, A SERIOUS STUDY, 80, Comer Road, St. Johns, Worcester, Worcs.
UFOSIS NEWS SHEET, 731, Hagley Road West, Quinton, Birmingham. B32 1AJ.
UFO INSIGHT, 277B, West Street, Crewe, Cheshire. CW1 3HU.
UFO WEST, 2, Berryman Court, Wells, Somerset.

MUNDO MONITOR, U.S.A.
CAMBRIDGE UFO RESEARCH, Canada.
UFO RESEARCH, Australia.
UFO BULLETIN, Australia.
LUMIERES DANS LA NUIT, France.
HYPOTHESES EXTRATERRESTRES, France.
PLANET, Turkey.
UFO INFORMATION, Denmark.
UFO-NYT, Denmark.
UFO-ASPEKT, Denmark.
NORDIC UFO NEWS LETTER, Sweden.
ODISEJA, Yugoslavia.
NYHETSBLAD, Germany.
NOTIZIARIO UFO, Italy.
UFO-FORSCHUNG, Germany.

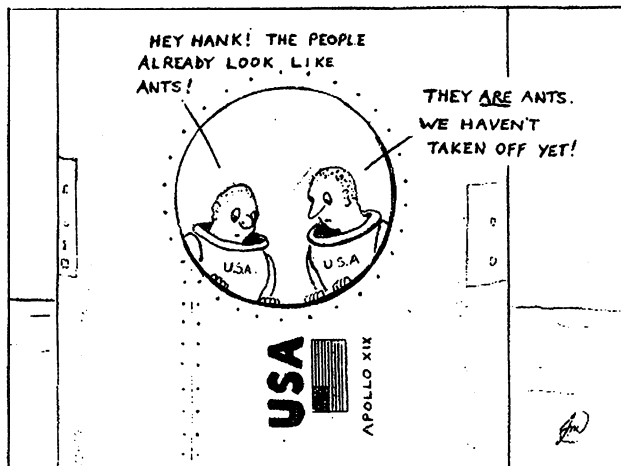



LOST: TWO UFOs! SEE PAGE 11 INSIDE.