

ORDERLANDS

ORDERLAND SEARCH

SINCE 1945

Ray-X Technology

and Experiments With Plants

Koyal R. Rife

Interstellar Communication

Medical Astrology

The Radiometer

and Thermodynamics

Ultra Microscopes

Page 12



US	\$6.95
CAN	\$7.95
UK	£4.50
NZ	\$7.95
AUS	\$7.95
JAPAN	¥695

NEW WORKS BY GERRY VASSILATOS

Author and researcher Gerry Vassilatos has spent years scouring Victorian scientific archives in search of the arcane, the anomalous and the amazing. The fruit of these searches is the release of a singular work of astounding depth and immense power... **THE VRIL COMPENDIUM**. This project is an ongoing major work which is to be published in successive complete volumes.

New Volumes! Compendiums 8 thru 11! Wireless Technology!

VRIL COMPENDIUM VIII — VRIL AND GROUND RADIO

The early history of wireless communications begins with the trans-aqueous systems of Steinheil (1838), Morse, Lindsay, Trowbridge, Highton (1852), Preece, Ratheneau and others. Complete patent collections: the ground signalling systems of J. Murgas, Tesla, Rogers, and others. Early accidental wireless transmissions of Elihu Thomson and others. Static-free reception for shortwave aficionado! Forgotten commercial underground antennas ("Subtennas", "Ground hogs"), buried coils, buried cables, underground terminals, oil-filled wells, and the Moon Co. "antennaless" radios will teach you how. Magnified radio transmission through geological formations. Geology dependent radio systems! Find out how entire VRIL regions are affected by the operation of small double-ground transmitters.

#B0336, 300 pages, ... **Catalog special \$39.95**

VRIL COMPENDIUM IX — VRIL AND AERIAL RADIO

Aerials not Antennas. Aerials as conductive terminals. Learn the relationship between electro-impulses and VRIL currents. Capacitative systems of enormous size and anomalous operation. Space rays and Ground rays meeting in transmitter components. VLF waveguides, valleys as radio-chutes. Oil-filled tanks as VLF radiators. Electrical architecture and VRIL articulations. Bent-L, Split-T, Split-Y and other huge systems. A fabulous array of names! Tesla, Fessenden, Lodge, Conrad, Butcher, Alexanderson, Squier, Thompson, Hughes, Fortesque, and many now-unknown designers. #B0337, 400 pages, ... **Catalog special \$39.95**

VRIL COMPENDIUM X — VRIL AND ELECTRIC RAY PROJECTORS

Special Light Rays and thready VRIL processions. Anomalous radiant phenomena. Visual and infrared photophones (A.G. Bell, S. Tainter, Stevens, Larigaldie, et.al.), and radiophony (Nikola Tesla, Augusto Righi, Bela Gati, Hammond Hayes, et.al.). Electric Rays, not waves. Rays and VRIL propagation through space! The original, forgotten, and unquoted Tesla paper (1892) describing radiant electric rays. Teslian "light-like rays"! Tesla multi-component detecting system employing Selenium. Photographs and articles. Remarkable raytube power transmitters of Reno and McCullough. Heitinger and the aerial skybeam power transmitters. Each working radio aerial system impossible to comprehend or rationalize from ordinary radio convention. Black radiance between white electroshocks. McCullough directive detecting tubes (related in operation to Moray listening detectors), Ulivi's strange explosive ray, Grindell-Matthews and his now-secret beam projectors, and many more. #B0338, 400 pages, ... **Catalog special \$39.95**

VRIL COMPENDIUM XI — VRIL AND ELF DEVICES

VRIL interactions and electrical irritants in the natural environment. Dangerous VRIL magnifications by electrical impulses. ELF and Project Sanguine articles. Modifying human behavior by ELF brainwave entrainment. HAARP Project patents! Includes large radio power installations of the early RadioAge. Impulse Power Generators of Shoemaker, Reisz, Vreeland, Farnsworth, Chubb, Piggot, and more. Rare period photographs and articles. Huge plasma arc oscillators of Lesh, Fritz Lowenstein (Tesla's assistant), and Valdemar Poulsen. A complete research thesis! #B0339, 440 pages, ... **Catalog special \$39.95**

Send all orders to:

Borderland Sciences Research Foundation

P.O. Box 220 ★ Bayside ★ California ★ 95524

or call 707-825-7733 to place your order by credit card. Please include \$3 each for p&h.

BORDERLANDS

A QUARTERLY JOURNAL OF BORDERLAND RESEARCH

SINCE 1945



page 6

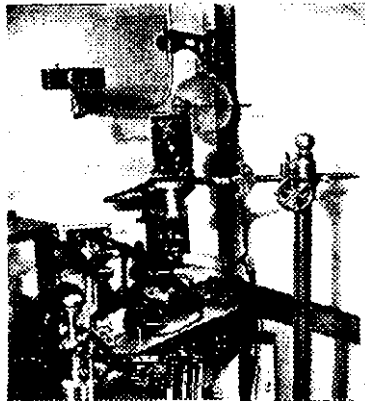

page 12

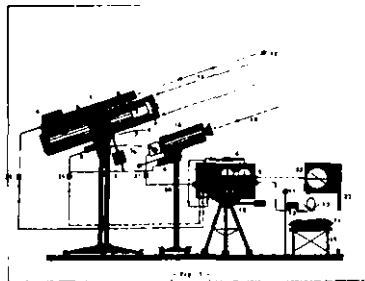

page 27

CONTENTS

FEATURES

THE RAY-X RESEARCH PROJECT: QUANTITATIVE AND QUALITATIVE ANALYSIS OF ALTERING THE EFFECTS OF EMF RADIATIONS
Michael Theroux 6

ULTRA MICROSCOPES AND CURE RAYS: DR. ROYAL R. RIFE
Gerry Vassilatos 12

INTERSTELLAR COMMUNICAITONS SIGNALS
L.G. Lawrence 27

WINDMILLS OF LIGHT: A SHORT HISTORY OF THE RADIOMETER
Franklin Ellsworth Clarke 30

MIND, FIRE, AND THERMODYNAMICS
Marion L. Daye 36

THE FOUR ELEMENTS IN MEDICAL ASTROLOGY
Judith A. Hill 48

IN MEMORIUM — A NEW ASSIGNMENT FOR A BSRF OLD-TIMER
Trevor James Constable 54

MUSIC AND NATURAL RESONANCE
Michael Riversong 61

COLUMNS

THE PUNDIT CURMUDEON — VERBAL MEANDERINGS — INCLUDING A DISCUSSION OF THE INTERNATIONAL TESLA SOCIETY'S 1995 "EXTRAORDINARY SCIENCE" CONFERENCE
E.D. O'Brian 58

DEPARTMENTS

EDITORIAL
Michael Theroux 2

CLIPS, QUOTES, & COMMENTS 3

REVIEWS
Michael Riversong 46

Editor
Michael Theroux

Consulting Editors
Trevor James Constable,
Vincent Gaddis, Peter Lindemann,
Jorge Resines, Gerry Vassilatos

Production Assistants
Michael Riversong
Deva Lynn Morris

BORDERLANDS

*A Quarterly Journal
of Borderland Research*

BORDERLANDS is the quarterly research publication of Borderland Sciences Research Foundation. Contents © 1995 by BSRF, Inc. Individual articles are © 1995 by the authors. All Rights Reserved. No part of this book may be reproduced in any manner whatsoever without written permission from the publisher, except by writers who may quote brief passages to be reprinted for review or reference. Please write to the publisher concerning requests to make use of any of the materials published in this journal, or contact the authors directly.

Borderland Sciences Research Foundation, Inc. was founded by Meade Layne in 1945 for the purpose of investigating into realms normally beyond the range of basic human perception and physical measurement.

BORDERLANDS originated as Meade Layne's *Round Robin* in 1945 and was changed to *The Journal of Borderland Research* in 1959, finally becoming BORDERLANDS in 1992. BORDERLANDS is an information nexus for thinkers and doers on the frontiers of science and awareness.

BORDERLANDS is available by subscription for \$25 a year, worldwide. Single issue newsstand price: US \$6.95 unless otherwise marked.

Subscription inquiries and address changes should be sent to our business office: BORDERLANDS, P.O. Box 220, Bayside, California 95524 USA. Phone: (707) 825-7733 or FAX: (707) 825-7779.

All article submissions and correspondence should be sent to: The Editor, BORDERLANDS, P. O. Box 220, Bayside, California 95524 USA.

For display or classified advertising write to the Advertising Manager at the above address for current rates.

BORDERLANDS can be reached on the Internet: <http://www.asis.com> — E-mail: bsrf@asis.com — <ftp://asis.com>

All published materials are presented for Informational and Research purposes only. Authors are solely responsible for the information and opinions they present. This material is not to be construed as expert opinion or medical advice, it is research into the Borderlands...

VIEW FROM THE BORDERLANDS

Editorial

WE have received many comments from our readers within the last few months concerning our current direction, what topics we should publish on, and the focus of our foundation. For the most part, we welcome your comments and requests, and we try to serve our readers the best way possible while maintaining the integrity and quality of the information we present. Our focus, which has been detailed in several past issues, is to feature the qualitative side of scientific investigation. This entails covering such diverse topics as Radionics, Free Energy, UFOs, Weather Engineering, Dowsing, Ether Physics—the list goes on. To us, each of these subjects possesses within it, in one form or another, a common seed which bears the fruit of qualitative research. This 'seed' is at once the *vital force*, and is the *prima materia*, if you will, of borderland inquiry.

We have had many requests for a "back to the basics" type column. In the coming issues we will be featuring just such a column which will cover the basic "how to" of disciplines such as dowsing, radionics, and many related Borderland subjects. We will also highlight several experiments in a step by step fashion for those who wish to reproduce them.

One of the larger projects we are currently working on involves making available all of the backissues of the magazine from 1945 to the present. Presently, only the table of contents is available. You can order the "Borderlands Table of Contents" from BSRF (\$6.95 + p&h) or download it free from the Internet at our website at: <http://www.asis.com/bsrf>. This is 50 years of borderland research in some 300 issues, which will be an excellent resource for the researcher and experimenter. This project should be completed by mid-year, and soon you will be able to order any issue from the table of contents listing.

This issue of the magazine marks the beginning of yet another exciting year of research. The article on the Ray-X Research Project is really more of a collaborative effort spanning several years of investigation. We are most indebted to all those who pioneered the techniques of plant research, and we hope to continue with many similar explorations into the world of plants.

The achievements of Dr. Royal R. Rife are well known to many of you, and Mr. Vassilatos' treatment of his work in the short biography featured here is quite historical in its significance. Not only was Dr. Rife highly regarded by his contemporaries, he continues to earn the esteem of many scientists today.

Next, we arrive at the extremely inspired work L. G. Lawrence. In the late 60s, at Giant Rock near Landers, California, Lawrence devised a complex monitoring system that could actually detect biological signals from outer space. The implications of this instrument are far reaching, and today, research groups are fast at work attempting to duplicate his early accomplishments.

While there are several more, no less significant articles between the covers of this issue, it seems I have run out of room to comment upon them. I'm certain they will be well read anyway.



Michael Theroux
Editor

Clips, Quotes, & Comments

BSRF on the Web

Thank you so much for bringing up a homepage on the Web! It's beautiful, it's informative. It's just right!

Trevor Constable's *Cosmic Pulse of Life* and *Loom of the Future* and video taken on the Maui served to introduce me to who you are and what you all represent. What I saw I liked, and so I joined, and paid my dues. Then, yesterday, much to my delight, I received my first copy of the BSRF Quarterly Journal (Vol 51, Number 4).

I thought I'd just take a moment to read the Editorial, and then return for more later. Six hours later I closed the covers. I couldn't take a break!

What an incredible document! And, Gerry Vassilatos — thank you so very much for telling us straight who Antonio Meucci really was!

— *Email from the Internet*

I just got my 4th Quarter BSRF Journal, noticed your web address, and checked it out. Great work! I look forward to cruising through BSRF materials online — especially the older stuff.

There is nothing like BSRF. I look forward to its quarterly arrival at my door. Thanks.

— *Mary Johnson, Kalispell, MT*

Analog vs. Digital

Thanks for the latest Borderlands. It's looking better all the time. I especially enjoyed the article on Digital/Analog recording (Meanings, Messages, and Signals, by Franklin Ellsworth Clarke, BORDERLANDS, 4th Qtr. 1995). I have noticed the rarefied atmosphere of CD recordings—it's as if I have to supply the feeling aspect by effort of will to enjoy them; which becomes tiring after awhile. I wonder if those recorded on gold foil instead of aluminium would have a different feel. Also, since most tapes are digitally recorded, how much difference is there from CD?

— *F. Brown, Santa Rosa, CA*

It would seem from our experience that tapes (which are not digital media) somehow give back some of the qualities of the original recording. I find that I prefer the sound of a tape recorded from a CD far more than the CD itself, and I experience no fatigue which is associated with CDs. This is one way to address the problem, especially since many new recordings are available only on CD.

Heroes and Geniuses

Assuming that Borderland Research includes those current scientific investigations that are pushing the domain of science into new and heretofore ignored or unacceptable areas of research, I have a suggestion.

In addition to the heroes and geniuses of yesterday, I would suggest a bit more attention be given to the geniuses of today that are pushing the borders of science into new, uncharted regions.

My list of today's geniuses would include Kenneth Shoulders, Stanley Pons, Martin Fleischmann, Robert Bass, Yasunori Takahashi, Hal Puthoff, Harold Aspden, Stefan Marinov, P. Tewari, Jean-Paul Vigier, John O'M. Bockris, James Patterson, and many others. These are they who are pursuing the new areas of science that are currently unacceptable to the current "within the borders" scientific dogma.

Briefly, their collective accomplishments in the field of new energy include the following three important new technologies: thermal power from cold nuclear fusion, electrical power generation from high-density charge clusters, and super magnets and super motors that provide mechanical power and self-generating motors. These three technologies are, in my considered judgement, the energy producing technologies of the late 1990s and the 21st century.

These technologies have two things in common, first they are inexpensive, essentially unlimited, and clean energy producing technologies. Second, they are all unacceptable to the current scientific models

(dogma) and therefore, are not supported by the "scientific community." The current status of cold fusion is best exemplified by the Patterson Power Cell™ which is achieving more than fifteen times the thermal output as compared to electrical input. Cold fusion is now being commercialized as indicated by the rumored purchase of a million dollar license by a Fortune 500 company.

The current status of the Shoulders high-density charge cluster technology is the ongoing development of new instrumentation and better devices. It is expected that sometime in 1996 Shoulders will demonstrate an electricity-producing device that will provide at least ten times as much electrical power output as input electrical power.

The Takahashi super motor (and the Kawai motor invention) achieves 200% to 400% more output power (combined mechanical power and electric output) as compared with electrical input power. A video exists that shows this new motor being connected to a pair of headlights. After being started by battery power, the motor/generator provides power to illuminate the headlights. Then the video shows the input power being disconnected and yet the motor runs and the headlights burn.

In our swapping publications with you, we encourage you to use our source material and provide your readers with more information on these important new borderland technologies.

Hal Fox, Editor, Fusion Facts & Energy News.

Thank you for your letter. Lately, we have been featuring the "heroes and geniuses" of yesterday. We hope that our revival of the work of many of these research pioneers will foster a renewed interest in what may, without constant reminder, be forever considered "lost technology".

BSRF has been investigating the idea of "free energy" for over 50 years now, and in that time we have seen many promising new technologies surface. When something new

comes along, we're always one of the first in line to check it out. Many of these new technologies have fallen far short of the claims made by their creators, but there is still some very promising work being done—especially by some of the researchers you mention. We have in the past published the work of some of these new “heroes”, and look forward to giving more exposure to them in the future.

Mystery No! Cover-up - Yes!

While flipping through the 3rd Quarter 1995 edition of BORDERLANDS, I came upon the inscription from the stone that was the subject of the article “Mystery Stone of New Mexico.” Without reading the article, I attempted to read the script, and recognized that the Israelites had struck again. The inscription was the Ten Commandments, and the Exodus 20 version at that.

As I began to read the article I became somewhat disturbed at how much misinformation could fit into two pages of a quality 'zine. The misinformation I speak of obviously arises from misinformation campaign from the slimy halls of Academia.

First of all, the writing is a version of ancient Hebrew of which there are many. [Other varieties have been found in Tennessee, Ohio and Louisiana (Washita Territory)].

Secondly, the source of this fictitious ‘Zakyneros’ is the word Zakor meaning ‘celebrate’ as in ‘Remember the Shabbat Day’ – the 4th commandment.

Exodus 20:2's reference to the ‘house of bondage’ (Beyt Obadim) is where they contrived that poor lost Zak was a wealthy slaveowner and furthermore there is no description of the area.

On a happy note, I've since come into much info that affirms Israelite presence thru-out this land thousands of years ago confirming the words of OAHSPÉ regarding the westward movement of the followers of Moses, the Israelites, and their subsequent bondage in Guatama (N. America), and information corroborating the story (as is now being told by the Empress of the Washitaw in ‘Return of the Ancient Ones’) that the trans-Atlantic slave trade in spite of its untold devastation did amount to a

family reunion tribally speaking.

Many stories by early explorer/exploiters have told of finding peoples in this land who had pronounced Hebraic customs. Today archeological evidence is slowly coming forward to affirm the presence of the Ancient Israelite. Who will believe the report. Shakhor-oo-Naweh.

Yehoshua Ben-Tzawdoq, Atlanta, GA

Sorry, no “slimy halls of Academia” here. You might take note that the author of the article used Dixie Perkins’ book, “The Meaning of the New Mexico Mystery Stone” as his main reference. Also, by some mysterious printing error, the facsimile of the inscription was printed upside-down. This actually raises some questions then, as it becomes obvious when turned right-side-up, that many of the letters themselves are “upside-down” such as ‘a’, ‘š’ and ‘k’ when compared with any of the scripts of such periods from the late Bronze Age to 2nd Iron Age.

Of course, many of these inscriptions when compared to others may look hundreds of years apart because of the different styles of the individual scribes. Maybe you could provide us with the version of the ancient Hebrew alphabet you used to read the stone’s inscription.

The Round Tower

Sometime ago you ran a brief note and photograph of what was referred to as a “Viking” tower in Newport (BORDERLANDS, 1st Qtr., 1994). When visiting a friend I have worked with for many, many years in Rhode Island, I had him drive me over to see this tower.

Clearly it does not resemble the old stone buildings and towers I have seen in Ireland and elsewhere in Europe. The construction is too “regular” in connection with the arches and the holes for holding beams,

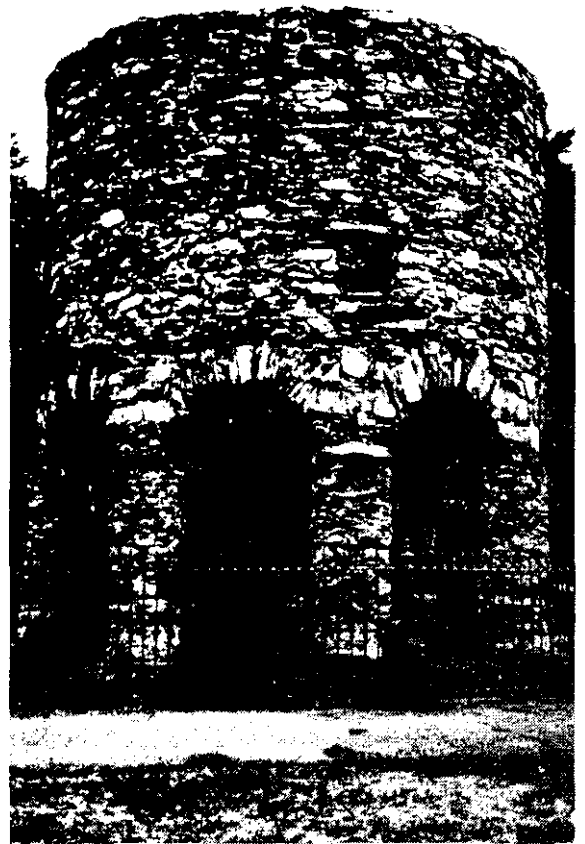

The “Round Tower” at Newport, Rhode Island

to fairly suggest that it goes back prior to the 1700's. There is an old record of a mill about where the tower is located.

In short, there seems to be no reason to believe that this tower is of ancient origin. But it is more romantic to believe that it was constructed before recorded time.

E.D. O'Brian, Portland, OR

GH-3 Support!

I will be 75 years old this year and my wife is somewhat younger. For about 20 years we both used the original GH-3 regularly, until our Miami supplier was put out of business. When our supply ran out we had no choice and stopped for about 6 months or so. Neither of us experienced any signs of withdrawal, no craving, no headaches, and no irritability such as described by “No name, no address” in your

4th quarter 1995 issue of BORDERLANDS.

We found a Canadian supplier, Gero-Vita International, which sells a legal and improved version of GH-3 which we now use.

We do not experience "euphoria" but do feel better. We are not "pill pushers" but do use aspirin, etc. for aches and pain when necessary (old folks feel the weather changes!) We know about Ronald Reagan and Alzheimer's but if there is a connection with aluminum, we don't see it.

I am a retired airline mechanic (Pan Am/Ual) in good health (prostate operation in 1993) and very active in "metal detecting" and travel. Other than the preceding, and not being a doctor/pharmacist/chemist/etc., I cannot comment further except as a science "buff," avid reader of BORDERLANDS, a former avionics technician, and psychic student.

B. Simon, Pacifica, CA

MWO on Court TV

With my cable television service, I receive Court TV and thought you would be interested in the following:

There was a case tried in San Diego where Laura Marks, in an action brought against a gypsy fortune teller, was charged by State of California. I missed most of the testimony, but in the summation the attorneys discussed first amendment rights, psychic practices, unfamiliar religions, and the use of a multi-wave oscillator among other matters.

The trial lasted about 3 weeks, ending in mid-December 1995 with a hung jury. Sorry I cannot give you any more information but if you want to look it up, CA vs. Marks. Case #110330.

J. Ochs, Fort Lee, NJ

It appears that things haven't changed very much. See the newspaper clip below.

AIDS Update

I think it is about time again for someone to interview Joan McKenna, Director of the Institute for Thermobaric Studies in Berkeley. Borderland interviewed her for the September/October 1992 magazine.

An update on the AIDS situation would seem in order. Her beliefs seemed more realistic than any of the others who are outspoken on the subject.

Laurette Hern, Carmel, California

Thank you for bringing this to our attention. We will be interviewing Joan McKenna for one of our upcoming issues this year.

Keep those letters, photos, and clippings coming! Please write to Borderlands CQC, P.O. Box 220, Bayside, California, 95524 USA. Letters may be edited for length and clarity.

Tons of Health Devices Seized Here



"Diagnostic equipment seized by officers in a series of raids on local chiropractors." This clip is from the Long Beach Independent newspaper, June 22, 1955. 50 radionic instruments were seized, and 6 chiropractors were arrested.

Report on the Ray-X Research Project

Quantitative and Qualitative Analysis of Altering the Effects of EMF Radiations

by Michael Theroux



ELECTROMAGNETIC fields (EMFs) and their detrimental effects on humans have become a popular topic among many researchers today. On one side of the debate, we still have researchers touting the possible healing effects of certain electromagnetic devices, while on the other side, investigative inquiries suggest that the effects of all EMFs are quite harmful to the living – citing such consequences as nerve damage, cellular disequilibrium, fatigue syndromes, and more. But, the argument cannot be thoroughly approached within the confines of modern analysis which defines an effect exclusively by that which it can measure. One must begin to understand that definite qualitative differences apply to this subject as well. These qualities cannot be assumed to represent only the component characteristics of electromagnetic fields such as the magnetic, electric, and the properties of these fields such as frequency or duration.

This is where we break with tradition by suggesting that EMFs and their associated components also possess differences in qualities not measurable by standard detection equipment. While conventionally we may measure the strength or frequency of a particular field, we have in no way determined all of its qualitative characteristics. A simple analog would be to say we have two baskets of ten apples. The apples in basket A look the same as basket B; there are ten in each basket (strength), and each basket weighs the same (frequency). But, upon tasting the apples, one finds the apples in basket A are much better than basket B, and basket A's apples are crisper. So, our quantitative analysis of measure and weight has done no service to our determination of these qualities. This, of course, applies to EMFs when determining their possible harmful effects on the living. The experiments provided in the following pages were initially designed to place emphasis on the understanding of their qualitative results, but as we shall see, certain quantitative tests can also reveal that a qualitative change has occurred.

Our focus in this report will be limited to those effects

produced by the emissions of computer monitors and televisions. Computer monitors and televisions all possess what is known as a CRT or cathode ray tube. The front of this tube is actually the screen of the TV or VDT (computer monitors are often called “visual display terminals”) and the tube functions by firing electrons at the phosphorus-coated screen to create the image. The emissions from the screen are composed of an electric and magnetic field and are at many frequencies, including ELF (extra low frequency), UV (ultraviolet), and visible light.

MAGNETIC AND ELECTRIC FIELDS

In order to understand what we are being exposed to in front of our computers and TVs we need to break down the EMFs into their respective components. The electric part of the field is the electrical charge surrounding an object. Electric fields are present whether a device is turned on or off. They are easily shielded by many objects. The magnetic field results from the motion of electric charge (current), and disappears when a device is turned off. Magnetic fields are difficult to shield, and will pass through almost anything that does not possess a high content of iron. Electric fields are usually measured in volts per meter (v/m), or kilovolts per meter (kv/m), and magnetic fields are measured in milligauss (mG).

Because the magnetic portion of the combined field goes through the body (penetrating the cell wall), it has been considered by some to be the most dangerous. While electric fields will stop on the surface of the skin, they should not be considered harmless. Which component of the field is more biologically damaging is still debatable. Studies suggest that dangerous exposure levels to the magnetic field are generally considered to be over 3 mG. Exposure to electric fields have been considered dangerous when they exceed 10 v/m. While these measurements may be a standard for primary exposure, the real threat is the accumulated exposure one might receive over time. This fact,

and others with regard to determining dangerous EMF exposure levels presents some difficulty for the researcher who only uses epidemiological studies (based on statistics), *in vitro* studies, and detection meters which can only relate a quantitative measure of immediate exposure.

VDTs AND TVS

Several studies have been conducted with respect to the dangers of EMF exposure from VDTs and TVs. These studies suggest that the effects of EMFs may cause changes in cell growth and function, increased tumor growth, central nervous system disruption, reproductive disorders, changes in blood chemistry, behavioral changes, and immune system dysfunction. For reference to these studies one should consult the list of source-material cited at the end of this article.

A catalogue of general complaints from computer users have included eyestrain, headaches, blurred vision, neck/back aches, facial neuralgia and blotchiness, etc. While these and most other symptoms had previously been associated with demanding visual work, conventional remedies by optometrists and physicians proved ineffective. It was suggested that another factor — EMF emissions from VDTs — was responsible. Personal experience with such symptoms prompted several researchers to investigate the use of devices to shield, block, cancel, or alter the EMF radiations coming from the screen. Our present examination will focus on the Ray-X technology developed by VriiTek Laboratories.

In order to confront the EMF/VDT problem effectively, the quantitative and qualitative emission components had to be individually examined. The first experiential dysfunction approached was the problem of eye-strain. The "refresh rate" of the VDT was considered the first suspect in the cause of most of the ocular fatigue. This refresh rate is the rate at which the image of the screen of the VDT changes, and is the cause for the vertical flicker one may see peripherally or through the playback of video images from a video camera. The next order of attention was the electric and magnetic fields. These fields would be considered responsible for many of the other fatigue related symptoms. The E-field static component can be as high as 6 kv/m (kilovolts per meter), but with many of the newer low-rad monitors the emissions are as low as 0.5 kv/m (still well above the suggested 10v/m limit). As for the magnetic component, measurements in the range of 5-30 mG are not uncommon. Finally, the emission of positive ions from the VDT/TV is considerable (readings of +1.0 kv and above are considered a health hazard by Swedish Labor Union standards), and symptoms from excessive exposure to such are identical to those complaints listed above. In this case, particles with the same polarity of the electrostatic field emissions from the screen (positive) are driven away from the screen toward the user, and seek grounding points which are provided by the user's face and hands.

Since most of the devices on the market designed to reduce or block these fields were somewhat effective in one or two areas, but not in all, it was decided that a newer approach to the problem was necessary. Simply blocking the field was out, as many of the devices designed to block fields added to the problem of eye-

strain, and really did little for the electric and magnetic fields. Cancelling the fields is a somewhat complicated task (due to the variety of field components) and did not afford a qualitative change in the field itself. It was determined that the only effective remedy was to qualitatively *alter* the fields themselves. The question then arises, "Aside from direct measurements, how does one know that these alterations in the fields have been effective?"

PLANT EXPERIMENTS

The development of the Ray-X technology, designed to alter the qualities of EMFs, was in part arrived at due to the researches of French scientist Georges Lakhovsky. Lakhovsky demonstrated that a qualitative difference could be demonstrated in living tissue via the use of certain devices he arranged for experimentation, and that regenerative effects could be produced by these devices as well. While *in vitro* studies could reveal much information, the most valid method of testing qualitative change would be to detail experiments *in vivo*. Therefore, living plants became the subjects of his research, and the qualitative effects of all types of radiant energies could be confirmed. It was only natural then, to test the efficacy of the Ray-X technology on living plants.

Lakhovsky specifically used a common variety of geranium (*Pelargonium zonatum*) for his researches as they were a hardy plant and could endure rigorous manipulation required by the experiment. For the initial tests with the Ray-X Button, several healthy geraniums of the variety *P. x domesticum* were acquired, and computer monitors of identical specifications were set up. Each geranium was carefully chosen for consistency in height and overall health. Two plants were situated directly in front of each monitor at a distance of 11 inches from the screen, and two controls were maintained. The Ray-X Button was affixed to one monitor only, and each of the plant/monitor stations was monitored for equal amounts of light and water for the plants. Exposure times for the plants from each monitor were regulated at 4 hrs each at the same time of day. Initially, a 30 day time limit was set for the experiment, but after only 15 days, the plants in front of the monitor *without* the Ray-X Button (A) showed considerable signs of stress in the form of yellowed leaves and loss of flowering. The plants in front of the monitor *with* the Ray-X Button (B) showed no visible signs of stress. The A plants also displayed retarded growth characteristics, while the B plants growth increased considerably — well above that of the controls (C). The C plants showed no signs of stress or substantial decreased/increased growth. These initial trials concluded that the Ray-X Button did indeed alter the quality of emissions from the monitor. The experiments have been reproduced at other locations as well.

The question at this point is how do we know that plant response will be any indication of the accumulated exposure by humans? We must turn to the pioneering researches of Jagadis Chunder Bose. In the early 1900s, Dr. Bose conducted thousands of experiments with plants using mechanical, electrical, and chemical stimuli. He was able to display that the physiological response in plants paralleled that of animals and humans — that the plants' sense perceptions were controlled by their own neurological functions. He noted that all responses in the living — and even the non-living — exhibited uniform reactions to uniform



Geraniums positioned in front of a computer monitor without the Ray-X attached. Note the striking disfigurement of the geraniums on the right, after 15 days exposure to the monitor radiations. These plants also suffered from stunted growth.



Geraniums positioned in front of a computer monitor with the Ray-X Button attached. After 15 days exposure to the monitor's radiations, these plants remained quite healthy and showed a considerable increase in growth.

stimuli, and that when a period of rest between stimulus was shortened, all exhibited signs of fatigue. Bose also determined from the conditions of experiment that a molecular derangement was caused by the stimulus, and that recovery was brought about by molecular equilibrium. When sufficient time was not allowed for recovery, a residual molecular strain would persist, and fatigue would diminish response. Fatigue was due to this strain and its cumulative effects. This is also in keeping with Lakhovsky's theories of disequilibrium in cellular oscillations.

Also of great interest is the interval between the incidence of the stimulus and the emergence of the response. This time is referred to as the latent period, and was found to exist among both animal and plant in Bose's experiments. Of particular significance were Bose's experiments with the plant's response to electric radiations. His results indicated that these radiations produced characteristic variations in growth, depending on the intensity of the stimulus. Feeble waves produced an acceleration in the rate of growth, while very strong waves produced a retardation, the effect persisting long after the cessation of the stimulus. Waves of

medium strength induced retardation in growth, but quickly recovered.

Many other notable plant researchers have been able to elicit similar responses. Cleve Backster, in the mid-1960s, showed that plants respond to a variety of stimulus by attaching his polygraph instrument to one of the plant's leaves, and observing the sensations on a penrecorder. The now famous philodendron even responded to his thoughts, and was able to sense the death of other organisms — in another room. Backster is to be credited with thousands of experiments, again establishing the plant as a sensitive entity capable of producing physiological response to a variety of stimuli.

Two years before Cleve Backster would begin his investigations, a researcher named Dr. John Ott began to study the effects of TV radiation on plants and humans. Prompted by an article in *Time* magazine which suggested that symptoms of nervousness, fatigue, and headaches (in a study on thirty children) were related to exposure from watching TV, Ott designed a simple experiment. He covered half of a TV screen with a shield of lead, and

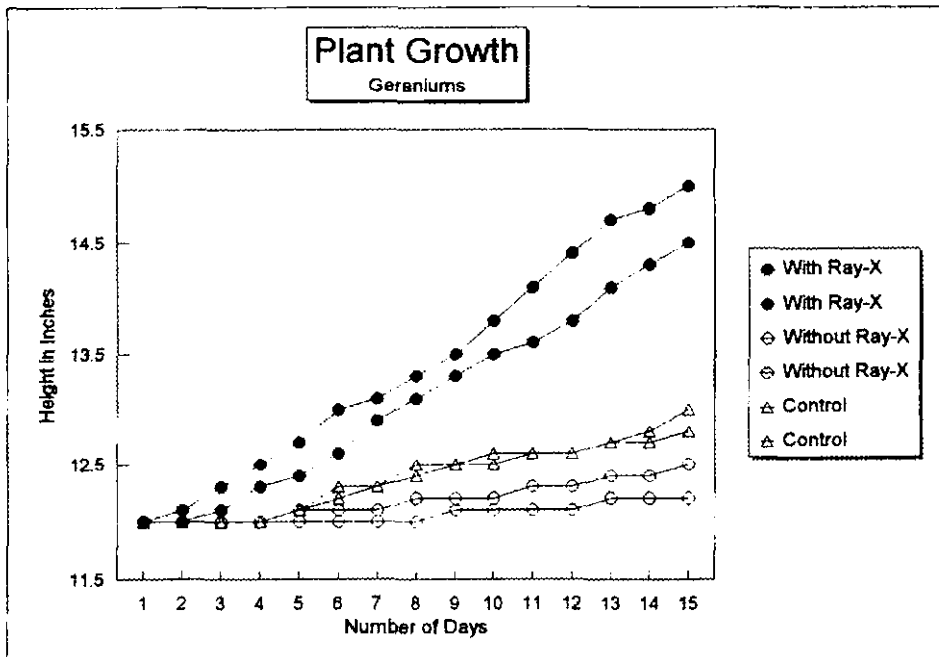

This graph depicts the differences in plant growth after 15 days exposure to computer monitor radiations. Plants with Ray-X showed considerable growth.

the experiment was to obtain a simple biofeedback monitor to attach to the plant. The biofeedback monitor we acquired measures galvanic skin resistance via a pair of electrodes, and the output is fed directly into an audio oscillator. One element of a Wheatstone bridge balances the resistance between the electrodes so that fluctuation in the plant's electrical potential can be measured, and this is heard as a rise or fall in pitch from the audio output. The interpretation of this rise and fall must be developed through hours of practise. Generally, a rising tone indicates a stress response, and a falling tone is indicative of a calm response. These cannot be strictly adhered to though, as it is very important to establish the quality of the rising or falling tone. Many factors must be taken into account when listening to the response such as the latent period (see above), duration of tone, fluctuation, speed of ascent or descent, and tone variation.

the other half with plain black photographic paper. Next, he placed six pots of bean sprouts in front of each half of the TV screen and as a control, six more pots were placed outside. At the end of 21 days, the sprouts in front of the lead shield and the outdoor controls had grown to a height of six inches — all appearing quite healthy. The sprouts in front of the photo paper (which allowed radiations to pass through it) grew into a disfigured vine-like shape.

The variety of plant used for the experiment was the common house plant, *Schefflera actinophylla*, due to its large leaves to which the electrodes could easily be attached. A mixture of agar was applied to the silver electrodes to insure an excellent and stable contact with the leaf. Initial contact with the plant usually

In the early 1970s, an electrical engineer named L. George Lawrence created an apparatus for detecting plant signals. Instead of using the entire plant, Lawrence utilized living vegetal tissues in his research instrument which were screened by a Faraday tube to shield out all electromagnetic disturbance. Irritations in the living tissue of the instrument were detected by listening to an audio tone rather than relying on the visual images of a penrecorder. This steady tone would change into distinct pulsations upon excitation of the vegetal tissue. Lawrence's instrument was not only directional, but could pick up disturbances of up to one mile away.

With all of this information readily available, and waiting for reproduction, it was decided that similar experiments might prove useful for determining the efficacy of the Ray-X. The first duty for

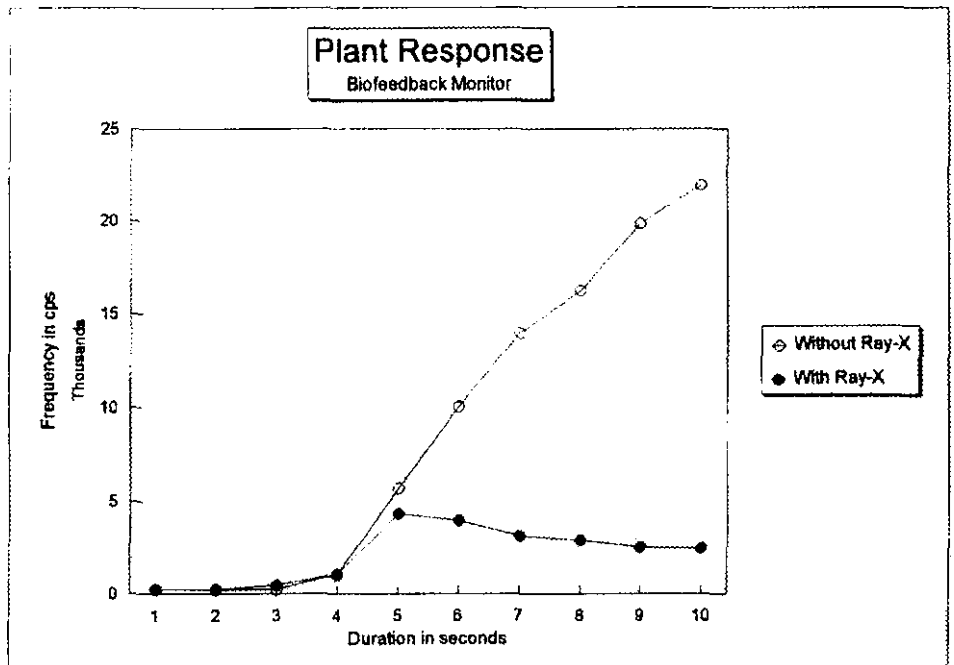

Graph of bio-feedback tests done with plants — with and without the Ray-X Button. The plotted frequencies are composed of the averages of 20 such experiments.

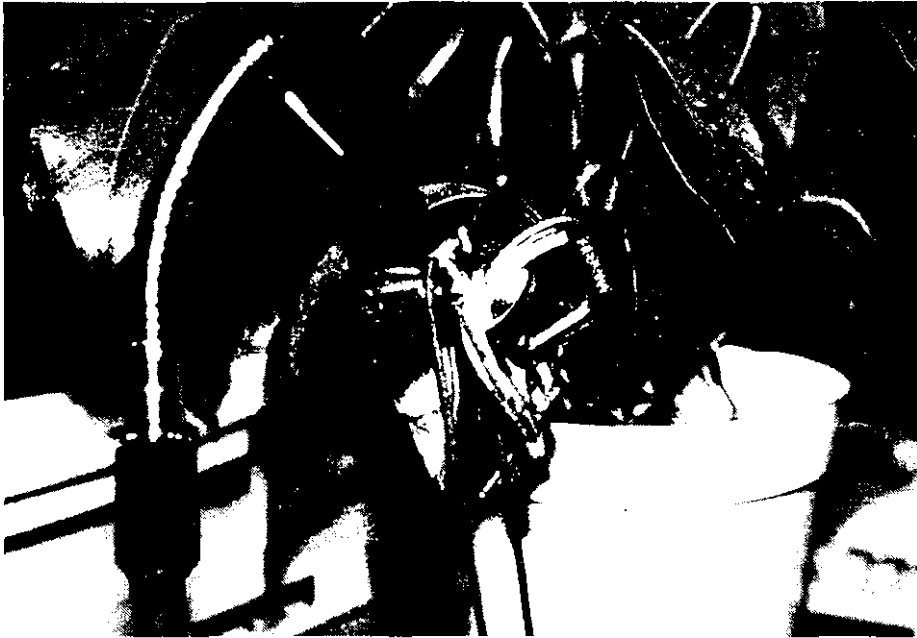

Experimental setup for bio-feedback testing of plant in front of computer monitor. Electrodes are of silver, and equal pressure was applied to the leaf.

causes a “shock syndrome” to set in, and the plant needs some time to adjust to the stimulus. After about ten minutes, a baseline could be set. This involves adjusting the audio output so that a steady signal can be heard. After obtaining the baseline, a computer monitor situated behind the plant was turned on. The latent period proved between two and three seconds, and then a steady rise in the tone could be heard. This climbed to a high frequency out of the range of hearing, and the audio output had to be adjusted accordingly. When the monitor was turned off, the tone diminished, but slower than it had risen — revealing the effect to be one of strong excitation. Next, we affixed a Ray-X Button to the monitor and once again turned it on. This time there was an initial rise in the tone, but it quickly leveled off, and then plummeted slowly toward the original baseline tone. This response indicates that there is not only a latent period in the plant, but one in the function of the Ray-X as well. Also noted was a characteristic “pulsation” in the tone, which was not present before the Ray-X was attached to the monitor. This experiment has been repeated several hundred times with the same response, proving the efficacy of the Ray-X in its ability to alter the emissions of the monitor field. It should be noted that the plant requires a period of rest between tests as continuous experiment will cause cessation of all response due to excessive fatigue.

FUNCTION OF THE RAY-X

How the Ray-X functions in these manifold ways has been a matter of some debate. Although its construction is proprietary, it is quite simple in design and was arrived at by a plurality of empirical findings during experimentation. The most important factors in its functioning are its abilities of accumulation, deflection, and reradiation. The Ray-X

needs no power for operation, and derives its action directly from the emissions emanating from the front of the screen. The antennas and body of the unit function as the accumulating section, and were tuned specifically to interact with the electric field. The Ray-X body coating contains substances which act on the magnetic portion of the field. This compound has been tested and used for years in other experimental instruments, and was chosen for its considerable ability to alter electromagnetic fields.

Independent studies have recently confirmed that the positive ion emissions from the screen undergo a complete polarity reversal when the Ray-X is attached. There is much evidence to suggest that negative ions are beneficial to living organisms, and positive ions are not. It is more likely that the problem of eye-strain is associated with the user's attraction of positive ions (as they are attracted to the the mucous membranes of the eyes) than with the visual

“flicker” of the refresh rate. The transmutation of positive ions into negative ions then, is of obvious benefit to the computer user. The inaugural tests were conducted with a Simpco Model FM-300 Electrostatic field meter. After careful preparation to ensure no personal static fields were present, the screen of a standard computer monitor (VDT) was measured at a distance of 12 inches without the Ray-X attached. The digital meter registered a screen radiation of +2.1 kv (remember, +1.0 kv and above is considered a health hazard). When the Ray-X Button was added to the screen, the meter immediately read -0.1 kv. More dramatic polarity reversals have been recorded with older, higher radiation com-

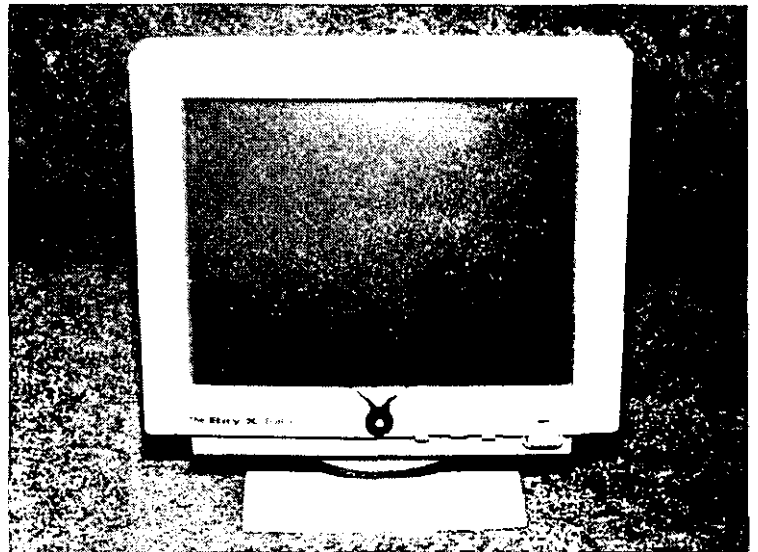

The Ray-X Button installed on a computer monitor. Wires are angled so that they touch the screen.

puter monitors and TVs. This quantitative analysis reveals that there is a distinct qualitative change occurring due to the operation of the Ray-X Button.

While more testing should be in order, the results of the research so far indicate that the efficacy of the Ray-X Button in its ability to alter all emissions from VDTs/TVs is exceptional. Research into other areas of the EMF problem is continuing, and similar devices have been designed to alter the EMF qualities of the emissions from florescent lighting and cellular phones.

CONCLUSION

The experiments set forth in this paper demonstrate that the Ray-X technology is effective in altering EMF radiations from VDTs/TVs. The consequence of the qualitative experiments with plants confirm that the Ray-X Button is effectively altering the quality of the emissions we receive from VDTs/TVs. The several quantitative tests performed with the Ray-X have concluded that over a short period of time there is a reduction in EMF potentials, and the various components of the fields have been altered significantly. These experiments are not completely unique, nor are they difficult to reproduce. With a minimum of time and effort one can easily set up an experiment such as the one designed to ascertain differences in plant growth rates. The weight of the information acquired from the experiments with plants lies not so much with determining the effects of the Ray-X, but with the fact that plants may be utilized as an excellent indicator of biological response. That we may observe parallels in the reactivity of plants and animals is of enormous import to the electromagnetic researcher, and should be pursued by all who wish to investigate this phenomenon. One final note on EMFs and the Ray-X: While this technology has proven itself in several experiments, all normal precautions with EMFs should be respected. I believe it was Trevor James Constable who once said, "Keep that infernal juice away from the body!" A point worth noting. ■

REFERENCES

EMFs & Bioelectricity

- Dr. Glen Swartwout, *Electromagnetic Pollution Solutions - What You Can Do to Keep Your Home and Workplace Safe*, 1991, AERAI Publishing.
- Roger Coghill, *Electro Pollution*, 1990, Thorsons Publishers Ltd.
- Laurie Tarkan, *Electromagnetic Fields - What You Need to Know to Protect Your Health*, 1994, Bantam Books.
- Ellen Sugarman, *Warning: The Electricity Around You May Be Hazardous to Your Health*, 1992, Simon & Schuster. (This one has an appendix of major studies conducted on the hazards of EMFs)
- Holger Luczak, "Work With Display Units 92," *Selected Proceedings of the Third International Scientific Conference on Work with Display Units*, 1993, Elsevier Science Publishers.
- "Electromagnetic Fields," *Consumer Reports*, May, 1994.
- Mary O'Connor & Richard Lovely, *Electromagnetic Fields and Neurobehavioral Function*, 1988, Liss.
- Robert O. Becker & Gary Seldon, *The Body Electric: Electromagnetism and the Foundation of Life*, 1985, Morrow.
- Paul Brodeur, *The Zapping of America*, 1977, W.W. Norton.
- George W. Crile, *The Phenomena of Life: A Radio-electric Interpretation*, 1936, W.W. Norton & Co. - Reprinted 1989, Borderland Sciences Research Foundation.
- Bob DeMatteo, *Terminal Shock: The Health hazards of Video Display Terminals*, 1986, NC Press.
- S. M. Harvey, "Characteristics of Low Frequency Electrostatic and Electromagnetic Fields Produced by Visual Display Terminals", 1982, Ontario Hydro Research Division.
- Fred Soyka, *The Ion Effect*, 1978, Bantam.
- Bert Dumpé, *X-Rayed Without Consent - Computer Health Hazards*, 1989, Ergotec Assn.
- George de la Warr, *Biomagnetism*, 1967, De la Warr Labs.
- "Electromagnetic Measurements and the Trifield Meter", Trifield Meter Pamphlet.
- "The Positive Effects of Negative Ions," *Health Freedom News*, Vol. 1, No. 3, September, 1982.
- Leif Floberg, *The Invisible, Insidious Dangers of Magnetism*, 1982, Lund Technical University.
- "Biological and Human Health Effects of Extremely Low Frequency Electromagnetic Fields," *Report of the Committee on Biological and Human Health Effects of Extremely Low Frequency Electromagnetic Fields*, 1985, American Institute of Biological Sciences.
- "Program for Control of Electromagnetic Pollution of the Environment: The Assessment of Biological Hazards of Nonionizing Electromagnetic Radiation," 1973, U. S. Office of Telecommunications Policy.

Plant Research

- Peter Tompkins and Christopher Bird, *The Secret Life of Plants*, 1973, Harper & Row.
- Jagadis Chunder Bose, *Plant Autographs and Their Revelations*, 1927, MacMillan Co. Reprinted 1990, Borderland Sciences Research Foundation.
- *Plant Response as a Means of Physiological Investigation*, 1906, Longmans, Green & Co. - Reprinted 1995, Borderland Sciences Research Foundation.
- *Comparative Electro-Physiology*, 1906, Longmans, Green & Co. - Reprinted 1995, Borderland Sciences Research Foundation.
- Patrick Geddes, *The Life and Work of Sir Jagadis C. Bose*, 1920, Longmans, Green & Co. - Reprinted 1992, Borderland Sciences Research Foundation.
- Bertha Mueller, *Goethe's Botanical Writings*, 1952, University Press of Hawaii - Reprinted 1989, Ox Bow Press.
- C.L. Kervran, *Biological Transmutations*, 1980, Beekman.
- Edwin C. Miller, *Plant Physiology*, 1938, McGraw-Hill Co.
- Phillip S. Callahan, *Tuning In To Nature*, 1975, Devin-Adair.
- Georges Lakhovsky, *The Secret of Life*, 1936, Medical books Ltd. - Reprinted 1994, Borderland Sciences Research Foundation.
- "Your Plants May Be Perceptive," 18 April, 1972, *Washington Post*.
- Thorn Bacon, "The Man Who Reads Nature's Secret Signals," 1968, *National Wildlife*.
- Arthur E. Eames, *Morphology of Vascular Plants*, 1936, McGraw-Hill Co.

Ultra Microscopes and Cure Rays

Dr. Royal R. Rife
by Gerry Vassilatos

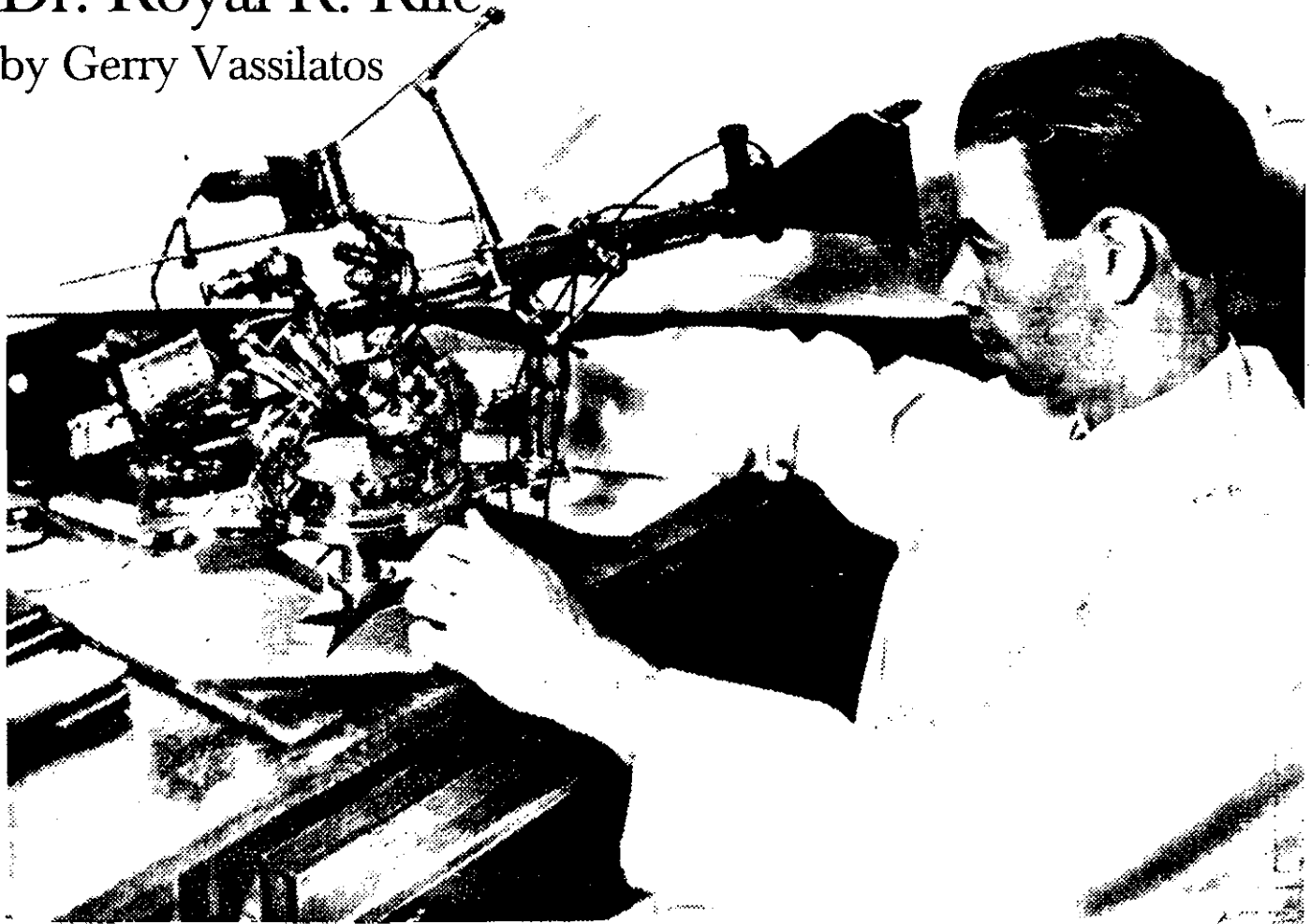

THERE is a constant war being waged which most prefer to ignore. Living out our days in the joyous sunshine, we rarely choose to glimpse full-faced into the horrid visage of disease as physicians so often do. Perhaps it is pain, perhaps fear. Despite our willful ignorance, hideous armadas of pathogens march through all nations unhindered. These insidious enemies wage their continual war against the human condition, with a cruel and merciless deliberation. Pride and wealth cannot keep these legions away. They are deadly,

having no conscience or allegiance. They are the universal enemy of humankind, a relentless foe. It is a wonder that nations have not surrendered their petty personal feuds long enough to recognize the common specter. Joining our best forces to defeat this dread army long ago would have secured major victories for all of humanity.

It has therefore fallen to the sensitive and impassioned few who seek alone, armed with vision and swords of light. The independent medical crusaders enter the battle alone. Their names are seldom seen in major journals any longer. Their private research forever dangles on gossamer threads of grants and endless bureaucratic labyrinths. Yet these are the ones, the men and women who make the discoveries from which cures are woven. Real cures.

They often live on shamefully minuscule budgets, preferring to pour out their personal funds into the work. They are the seekers. They are always close on the brink of a possible new development. One never knows when such will come. The important thing is that they are prepared, and wait in prepared chambers for the gracious and providential revelations upon which humanity depends. Theirs is the excitement of the chase. Their quest is "the breakthrough".

They are the ones who fill little lab rooms, closet spaces which line university hallways. Their intuitive vision has guided them into research alleys which are too small for the big concerns of profiteering medical agendas. If these researchers are fortunate, they find an impassioned patron. Perhaps the patron is a sensitive one, whose life has been touched with the sting of tragedy. Perhaps a loved one was lost. Perhaps also in the heat of that pain, the recognition came that gold must be transmuted by passion and devotion before it can cure. These quiet ones who go about their work daily, so many devoted hearts, are driven on behalf of all who bear such sorrow over what has been lost.

There was once such a man. His discovery gave eyes to the blind. He perfected a means by which humanity's enemies could be detected. His microscope could optically sight viruses, and sight them in their active state. And he developed a means by which viruses, any virus, could be eradicated with the flick of a switch. His medical developments won him no reward because his research did not fit the desired agenda.

The Microscope. The Super Microscope. There were predecessors to the prismatic marvel of Dr. R. Raymond Rife, but no equals. Others had designed and used oil immersion lenses, dark-field illuminations, and deep ultraviolet light, each holding part of the secret for optically magnifying infinitesimal objects. But the design which Dr. Rife developed outpaced all of these.

It is doubtful whether you have ever heard his name. Reasons for mass-forgetfulness run deep. Truths have been kept from you. Only a careful and relentless study of the past will relinquish secrets purposefully and cunningly buried. The information is safely nestled in dust laden libraries which few now venture to search. Perhaps you will recognize why his name has been blotted out of the historical records before we reach the end of this amazing biography.

Dr. Rife began as a research pathologist. A medical crusader of the very highest qualifications, is was a heart filled with but one goal: the eradication of disease. Dr. Rife recognized first and foremost that successful medicine relies on vision, on light. What

we cannot see we cannot battle. An unseen foe is impossible to destroy. Therefore his first quest was to secure a vastly improved system of microscopy. Once he could see, once all could see, then the pursuit of medical knowledge could again move forward. An armada of equipped seers could assail the foe on every shore. Looking for more light.

Dr. Rife's study of microscopy detailed every component and premise which tradition had presented to our century. The creation of a super microscope would run counter to every physical law and restriction which the previous two centuries had accumulated. Academes began again to love the writing of papers. Without the exercise of experiment, however, all these papers were so much tinder.

Dr. Rife wanted to develop super microscopes capable of seeing viruses. His aim was to chart and catalogue them, understanding that these represented a deadly foe which exceeded bacilli in their destructive assault on humanity. His quest now began. He reduced the fundamental premise by which microscope design had developed, analyzing each separate component and premise.

FOCUS

Optical designers had been adding ever more complex components to the design which began with van Leeuwenhoek. Lenses were compounded to lenses, crowns were added to compounds, crowns were added to crowns...the complexity was frightful. Simplifying the problem necessarily led to Rife back to the study of optical geometry and the comprehension of simple ray divergence.

Rife thought on these ancient principles. An ideal magnifying system is a geometric construction of extreme simplicity. Diverging light rays can magnify any object to any magnification. Given a strongly divergent light source and a great enough distance, one can theoretically magnify the indivisible! This is the principle which underlies projection microscopy. Dr. Rife realized that the projection microscope represented the best and simplest means for magnifying infinitesimal objects. One simply needed to discover a means by which a vanishingly small, brilliant radiant point could project divergent rays to the surface of any material speck. No virus, however indistinct and cunning, could hide from such an optical magnifier.

The theoretical design of microscopes relies purely on geometric principles. Actual materialization of these principles requires material manipulation, since geometric rays and light rays are significantly distinct. What is a microscope essentially? What is achieved in a microscope with light rays? The notion is quite simple. Take divergent rays from a vanishingly small point of brilliant emanations and allow them to pass through any specimen which is to be viewed. Light from this encounter is then made to diverge as far apart as possible in a given space. Geometrically it is possible to divert rays from a vanishingly small point out to an infinite distance. This geometric construction would produce unlimited (ideal) magnifications. Provisions toward this ideal goal would require that the point radiant source be tiny and brilliant enough, the specimen be close enough to the radiant point, and the image diverging space be very long. The geometric divergence of the point light source is the magnification factor. But geometry is an idealized reality. And ideal geometry encounters significant

frustrations when implementing light in inertial space.

The most basic type of microscope is the projection microscope. It is the most simple system which is employed to greatly magnify the most infinitesimal objects. In the more common version, light is made to pass through a tiny specimen. Light from the specimen is forced to diverge across a long space by means of a very small focussing lens. Rays from this lens cross, diverging and expanding across a long space. This widely divergent beam is then projected onto frosted glass. The viewing of images derived through these means is indirect, but provides superior magnifications with ultrahigh resolutions.

Formerly, laboratories required compact units capable of close personal manipulations. The development of fine optical microscopes became frightfully complex when more powerful but compact models were required. The notion of a compound microscope is to physically compress the long projection space into a compact tube, delivering the shrunken design to customers who wish to conserve space. The "problem" with compact optical microscopes was bending the necessary wide beam through a small space. The "trick" in a compound microscope was to keep the image rays from prematurely diverging between lens stages.

The long expansion space required for divergent beam magnification had to be "folded" and "convoluted" within imaging tubes. Large numbers of lenses performed this duty. Being thus "convoluted" by lenses to achieve magnification, images produced by most expensive bench microscopes were inherently limited. Since the diverging image in these microscopes is "interrupted" within a greatly shortened space by means of several optical stages, it cannot produce great magnifications with either clarity or brilliance.

Each optical stage continually bends the image until a tremendous effective divergence is achieved. The effects are dramatic, but the necessary stages introduce optical resistances by which magnifications are inherently limited. Fundamental problems with white light alone complicated the problems which designers faced. Breaking into spectral components, each color refused to focus in exactly the same point. As a result, chromatic aberration blurred every image.

The light-crossing action of each lens brought widely diverging light beams into the ocular lens. It was pivotal that these rays be parallel. Images lost most of their radiant power against the tube walls before arriving in the final ocular. Therefore more corrective lenses were added in the beam path to bend the light back from the tube walls. Differences when light travelled between lenses and air introduced more aberrations. Batteries of corrective lenses, crowns

and compounds, so loaded the light path with crystal that images lost their original brightness. These horrendous optical problems were never completely solved, despite the high cost of these instruments.

All of these optical horrors were the result of an old tradition which yet compels designers to maintain familiar outward forms. The projection microscope is so simple and potent, one wonders why newer designs had not been developed with as much dedication and zeal. It was the outward form which compelled the convolution of projection microscope simplicity, detracting from the excellence of magnified images. What was really lacking in optical microscopy was the development of true, tiny radiant points of monochromatic light. These diverging ray sources could produce novel and economical projection microscopes.

The numerous optical components of most excellent laboratory microscopes are configured to prevent image splitting, image incoherence, and other optical aberrations. All the differences between geometric ideals are suddenly and severely limited when using light and glass. The optical ideals come short of the geometric ideal.

Geometric rays do not fade with infinite distance. Light rays do. Geometric rays do not blur at their edges with increasing divergence, Light rays do. Geometrically magnified lines do not diminish in their intensity Light images do. A successful optical approximation to the geometric ideal would produce a super microscope. Dr. Rife decided to manipulate all the possible variables in order to approach, as closely as possible, each part of the ideal geometric construction. If such a feat could be accomplished, he would have successfully bridged the gap between optical and electron microscopy.

POINTS

To be sure, numerous individuals had accidentally discovered enormous magnification effects while experimenting in completely different fields of study. A magnifying system which magnified much smaller infinitesimals than viruses appeared in 1891. Nikola Tesla developed a remarkable carborundum point vacuum lamp and made an accidental observation which opened a new world of vision to science.

Tesla began inventing single wire vacuum lamps for purposes of illumination. These were large glass globes powered by very rapidly impulsed currents. The impulse currents made the single supported wires glow to white brilliance, melting them. Impractical for public use, he sought to alleviate this condition by using special crystals. High melting points were required. An assortment of such

Dr. Rife decided to manipulate all the possible variables in order to approach, as closely as possible, each part of the ideal geometric construction. If such a feat could be accomplished, he would have successfully bridged the gap between optical and electron microscopy.

materials were poised at the single wire termination. When electrified, they suddenly became radiant.

His experiments included using diamond, ruby, zircon, zirconia, carbon, and carborundum. He found it possible to blast the natural gems after a few seconds' electrification time. But before exploding, each of these crystalline terminations released puzzling patterns of light across the globe surface. This symmetrical pattern of points attracted Tesla's attention. They appeared when the current was turned on for just an instant.

Moreover, Tesla noticed that the brilliant fixed points of light remained in fixed positions each time he applied the current. Equally astounding was the fact that each material portrayed distinctive point symmetries upon the glass enclosure. The most resilient and successful crystalline material was carborundum, which he ultimately adopted for practical use. This too gave its characteristic point symmetry across the globe.

Tesla was not sure what he had discovered. He intuitively surmised that these point patterns of light somehow revealed the crystalline structure of the excited material. He also utilized the geometrical construction to obtain his deduction. His thoughts turned to the internal crystal conditions. As electrically charged particles were propelled and ejected through the carborundum, they were deflected by infinitesimal points. Diverging from such infinitesimal points, they impinged upon the inside spherical globe which housed the carborundum point. These brilliant points of light were always of the same symmetry because the ejected particles were passing through a fixed grating: a crystalline grating.

He theorized that this fixed pattern represented the greatly magnified crystalline symmetry. This simple apparatus was the world's first point-electron microscope. The phenomenon responsible for the defined projection of crystalline spaces is referred to as "field emission". Later, others would duplicate these same results with other crystalline specks. The remarkable X-Ray photography of Max von Laue already permitted the sighting of crystalline atoms. In this scheme a thin crystal point was placed at a critical distance from an X-Ray source. Entering and passing through the crystal slice, divergent X-Rays produced a greatly magnified image of crystal atoms on photographic negatives.

The result of von Laue's experiment was astounding, but was a purely geometric consequence. Divergent rays from a vanishingly small radiant point can theoretically magnify equally small specks to immense size. But while both Tesla and von Laue produced wonderful results with particle-like emissions, the practical achievement of these ideals were diminished when using optical light rays.

Emile Demoyens (1911) claimed to have seen extremely tiny mobile specks under a powerful optical microscope...but only at noon during the months of May, June, and July! Colleagues thought him quite mad, but Dr. Gaston Naessens has comprehended why these specific time periods permitted such extreme viewing. During these seasonal times the noonday sunlight contains great amounts of deep ultraviolet light. The shortened wavelengths provide a sudden optical boost, permitting the observation of specks which are normally invisible.

Progress in optical science seemed limitless and free. It was anticipated that no limit could bar humanity from viewing the very smallest constituents of matter. But when the physicist Ernst Abbe

challenged the high hopes of optical science by imposing certain theoretical limits on optical resolution, all these hopes seemed to dissolve. Abbe claimed that optical resolution depended entirely upon incident light wavelengths, the limit being one-third of the light wavelength used to illuminate the specimen. According to Abbe, the extreme ultraviolet light of 0.4 microns wavelength could not be used to resolve the details of objects smaller than .15 microns.

This theoretical "death-knell" discouraged most optical designers of the time. Since, he claimed, resolution of optical microscopes was restricted from 1600 to 2500 diameters, developing newer optical microscopes was a futile pursuit. Since resolution is the ability of a magnifying instrument to identify details and ultrafine levels of internal structure, the Abbe limit imposed a serious halt on the development of newer optical microscopes.

Continual medical progress rides entirely on the excellence of its instrumentalities. In the absence of new and excellent optical instruments of greater precision, medical progress grinds to a screaming halt. When this happens, academes write papers in the absence of true vision. True knowledge, reliant on vision and experiment, is replaced by unfounded speculation.

Others conceived of electron microscope designs, taking advantage of the Abbe restriction for lucrative purposes. These developers were not good planners, failing to recognize that electron microscopy would place equally grave limitations on biological researchers. Electron beams kill living matter. Magnifying images only after killing them, no living thing could ever be observed in natural stages of activity through electron microscopy. But, if money was to be made, then "all was possible". Despite the protests of qualified medical personnel, RCA continued its development with Zworykin at their helm.

Electron microscopy, rationally impelled by the Abbe limit, became the new quest of young financiers. despite the protests of major researchers, RCA continued its propagandist campaigns. This technological imposition, were it developed into a marketable product line, would severely handicap the work of every medical researcher. Pathologists would be literally forced to accept the limitations of the anticipated electron microscope.

Bracing themselves for the announcement of mass-produced electron microscopes, corporate researchers prepared themselves for the laboratory adaptations they would be forced to adopt. Manuals were already being distributed. They would be unable to watch progressive activities in the boasted "highest magnifications ever achieved". Before RCA reached the goal however, others had already challenged the capabilities of electron microscopy. The unexpected development temporarily threw RCA off balance. The competitors had challenged the Abbe limit, and seemed to be optically working their way into realms in which RCA had claimed "exclusive" rights.

DEEP VIOLET

Vibrating above the deep ultraviolet range were the X-Rays of von Laue's projection microscope. But this realm was not good for pathologists since X-Rays would only reveal the structure of crystalline substances. Some designers went ahead and built soft X-Ray microscopes. These devices placed heavy requirements on the preparation of specimens. X-Rays passed right through specimens

and would kill them if they were alive to begin with. The very best X-Ray images of tiny specimens required organism-killing metallic stains. Biologists needed to see their specimens in the living state.

While engineers at RCA were yet scrambling to take the competitive edge and seize the new market, several designers of ultra-microscopes began to successfully challenge the Abbe limit. Abbe stated that the maximum resolving power of any ultraviolet ray microscope would be restricted from 2500 to 5000 diameters and no further. But ultra-microscopes constructed by Graton and Dane (Harvard University) succeeded in developing resolutions of 6000 diameters with magnifications of 50,000 diameters.

Dr. Francis Lucas of Bell Telephone Labs developed a modified version of this system in which a maximum magnification of 60,000 diameters was developed. Not only did this work significantly reduce the theoretical limits set by Abbe, but the ultra-microscope which Dr. Lucas designed actually empowered Bell Labs to compete with RCA in the microscope field. Dr. Rife had previously achieved resolutions of 6000 diameters with resolutions of 50,000 diameters. And now, Dr. Rife believed he had a means by which these preliminary feats could be greatly outperformed. The Abbe Limit, a theoretically perfect expression, was dissolving before the new empirical evidence.

Of course, RCA ultimately outdid the propaganda campaign for their own electron microscope system, wiping out the optical systems of both Bell Labs and Harvard University. Nevertheless, independent researchers preferred these ultraviolet microscopes to any system which RCA could market. Attractive because the ultraviolet microscopes permitted life-active observations, pathologists were not impressed by the extra magnifications of electron microscopy.

OBJECTIVE

Ultraviolet light for ultra-microscopes is an absolute necessity. The successful operation of any such device depends on deep UV rays. Monochromatic ultraviolet sources prevented many of the familiar optical aberrations common to optical microscopy. Blurring and fringe degeneration when passing through the optical resistance of lenses would be minimized. The ultraviolet source would also need to be of the shortest possible wavelength in order to approach the geometric ray ideal.

All optical components in the ultra-microscope would then have to be composed of pure quartz crystal in order to flawlessly transduce the deep ultraviolet rays. Even the specimen slides were made of thin quartz glass. The ultra-microscopes of Dane, Graton, and Lucas used as few lenses as possible, being virtually pure projection microscopes.

According to Dr. Lucas, resolution one-tenth of the illuminating

light wavelength was obtained. This broke the so-called Abbe optical restrictions by an order of 300 percent; the resolution being brought up to .05 microns. How was this possible? Drs. Dane and Graton further stated that far greater resolution could be obtained through lenses than claimed by their manufacturers. The reason for this? So long as the manufacturers had accepted the theoretical limits there was no incentive toward progress in the field. No one bothered to find out!

The ultra-microscopes demonstrated beyond question that lenses do in fact surpass theoretical limits. The manufacturers, eager to maintain credibility in the academies, had simply endorsed whatever the physicists wrote. Equally as significant was the fact that each of these ultra-microscopes did not require the fixation of specimens before viewing. The embodiment of each ultra-microscope gave new drive to researchers who wished to see live

pathological stages in tissue cultures. The systems were immediately demanded and obtained by numerous serious research institutes on both sides of the Atlantic.

Certain highly respected researchers came to believe that the most basic laws concerning physical light were fundamentally flawed. Perhaps light was of an entirely different nature than supposed. This, they mentioned, was why the Abbe limit was such a distorted mathematical expression. Light was not what the physicists declared it to be. This is why Abbe's assessment was so obviously flawed. But what other assumed truths were holding back fresh discovery? Empirical observations now replaced the theoretical piles with discoveries which were once termed "unlikely" by qualified authorities.

When researchers realized the great cost which the Abbe limit had so long imposed on microscope designers, they began challenging every known theoretical limit which pertained to their fields of study.

Every scientific premise was questioned during the astounding decade of the 1930's. Every applicable optical rule was again subject to fresh questioning, the epitome of renewed scientific mind. New vision filled the researchers, challenging the inertial world again. The most significant effect of these new ultra microscopes was a renewed questioning process. Now also pathologists and biologists alike were given instruments with which to peer into the most infinitesimal natural recesses.

With the ability of medical researchers to peer into the deepest pathogenic lairs, new cures for ancient maladies could be effected. The war was on, and fresh crusades came to the battlefield armed with light. Curiously, the lines of battle brought two distinct groups to fight the same foe. Unfortunately, one group desired all the glory

**Certain highly respected
researchers came to
believe that the most basic
laws concerning physical
light were fundamentally
flawed. Perhaps light was
of an entirely different
nature than supposed ...
Light was not what the
physicists declared
it to be.**

and crushed its more sensitive brother.

Rockefeller Institute extended their campaign by highlighting the efficacy of electron microscopy, securing the sale of their new units. The RCA cash flow was unrestricted now. Electron microscopy coupled its forces with the pharmacological industry, producing its line of allopathic medicines. Those who took upon themselves the inquisitorial profession, rather than the profession of truth, found themselves drowning in seas of new developments which their business-minded patrons wished to eradicate. Independent university researchers maintained their poise as the prime recipients of fresh and astounding discoveries which shook the medical world. This would not long be tolerated by the growing pharmaceutical monopolies and trusts who wanted total domination of the field.

MAGNIFICAT

The encroaching economic depression of the time period had crushed the general populace. Dr. Rife had been designing and assembling ultraviolet projection microscopes of superior quality from 1920 onward. He had planned to build a far superior instrument. The super microscope. The design was based on theoretical considerations developed during his preliminary experimentation in optics. Now this work was abruptly terminated. Finding himself out of employment, Dr. Rife sought the ordinary work of those who are in need. Humbled and not proud, he sought a salary in less intellectual venues for the time being.

Hired as private chauffeur by H.H. Timkin, a wealthy and philanthropic motor magnate, he gradually won both the respect and willing ear of his adventurous employer. He could not keep his wonderful dream to himself. On long journeys to boring board room meetings, Timkin engaged Dr. Rife in detailed discussions on his medical work. Dr. Rife eagerly entered these discussions with an enthralled candor which caught his employer quite by surprise. The seriousness and integrity of the man did not catch Timkin by surprise. He recognized quality when he saw it, and listened.

The man's great stature was not hidden, despite his humbled position. But when he spoke of these designs and research goals, the very air began to brighten around him! He mentioned regret at having to postpone his work, but was very sure that all would turn out well. What he had shared was enormous. Inspiration of the purest kind. When Timkin and his business partner Bridges realized exactly what Dr. Rife had hoped to achieve, they made a resolute decision to arrange financial support for the work at hand.

Timkin and Bridges created an endowment fund to finance Dr. Rife and his astounding research. Rife was delighted. Delighted to tears. An emotional man, he promised that no one would be disappointed. He would work until success. A laboratory was constructed on the Timkin estate grounds, (Point Loma, California) and Dr. Rife set to work with a fury which surprised those who lovingly surrounded him. Timkin and Bridges were taken aback by the rapidity with which Dr. Rife completed each design which he began. His efforts were relentless, a true inspiration to the equally loving people who supported his research. It was very apparent that the pensive and gentle doctor was serious in the extreme.

Dr. Rife aggressively pursued and achieved what had not been done in the field of ultra-microscopy. His mind had turned over the method which he had conceived so many years before. The dream

which Dr. Rife originally received was now in view. Looking for more light. He decided to try filling the entire objective with cylindrically cut quartz prisms. There would be no difference in refractive index from start to finish along the optical path. Quartz prisms would "open out" each ray convergence, maintaining strictly parallel ray cadence. An increased ray content being thus returned to the ocular, the image would be brilliant in appearance and of high resolution.

This configuration of quartz prisms caused the rays to "zig-zag" in 22 light bends. The internal optical path was now entirely composed of 22 quartz blocks, fitted snugly to lenses. It was as if the entire device were one solid crystal of diverse surfaces. Now, specimen emergent light would launch out in parallel paths through quartz prisms, being magnified only when they reached each quartz lens. This optical tracking method would insure the brilliance of the emergent image.

A second optical innovation was added to this brilliant configuration. Dr. Rife decided to use a phenomenon by which strong specimen-entrant light stimulates internal fluorescence in the specimen. Pumping the specimen with brilliant ultraviolet-rich light would shift the divergence point into the very heart of the specimen rather than beneath, forcing the specimen to radiate its own brilliant ultraviolet rays.

Here was a true, vanishingly small radiant source with which to illuminate the specimens: they themselves would become the radiant source! This concept was truly sublime, since the very infinitesimal particles themselves were now made to radiate brilliant and divergent rays. This scheme was truly original from the very start. Dr. Rife then designed a system by which selected portions of the ultraviolet spectrum could be split and directed into the specimen using a polarizer. Turning this component of the system would allow each specimen to brightly fluoresce in its own absorption spectrum, the infinitesimal specks radiating their own maximum brilliance.

Theoretically, it was possible to magnify these brilliant specular rays to any degree. But a secondary monochromatic ultraviolet ray would perform an unheard wonder. When combined with the brilliant internal fluorescence of the specimen, this secondary ultraviolet addition would heterodyne the light. This meant that light pitches from the specimen would be raised far above its original values. At such shorter wavelengths, the resolving power of this device would be incredible.

An additional monochromatic deep ultraviolet beam was mixed with the fluorescent radiance of specimens, producing an astounding visual sharpness of otherwise invisible objects. The illumination scheme and the tube-filled clustre of quartz prisms (designed to maintain the specimen emergent rays in absolute parallels) were now brought together. Dr. Rife claimed that these parallel lines were within one wavelength of accuracy, an astounding claim.

He soon created a small ultra-microscope whose fundamental mode of operation violated the supposed laws of optics. This design outperformed all previous ultramicroscopes. So astonishing was this feat that the Franklin Institute, in rare form, published a long and detailed series of articles concerning the developments of Dr. Rife. They were also given several of these units for preservation, where they remain to this day.

This microscope was different, totally different. This microscope

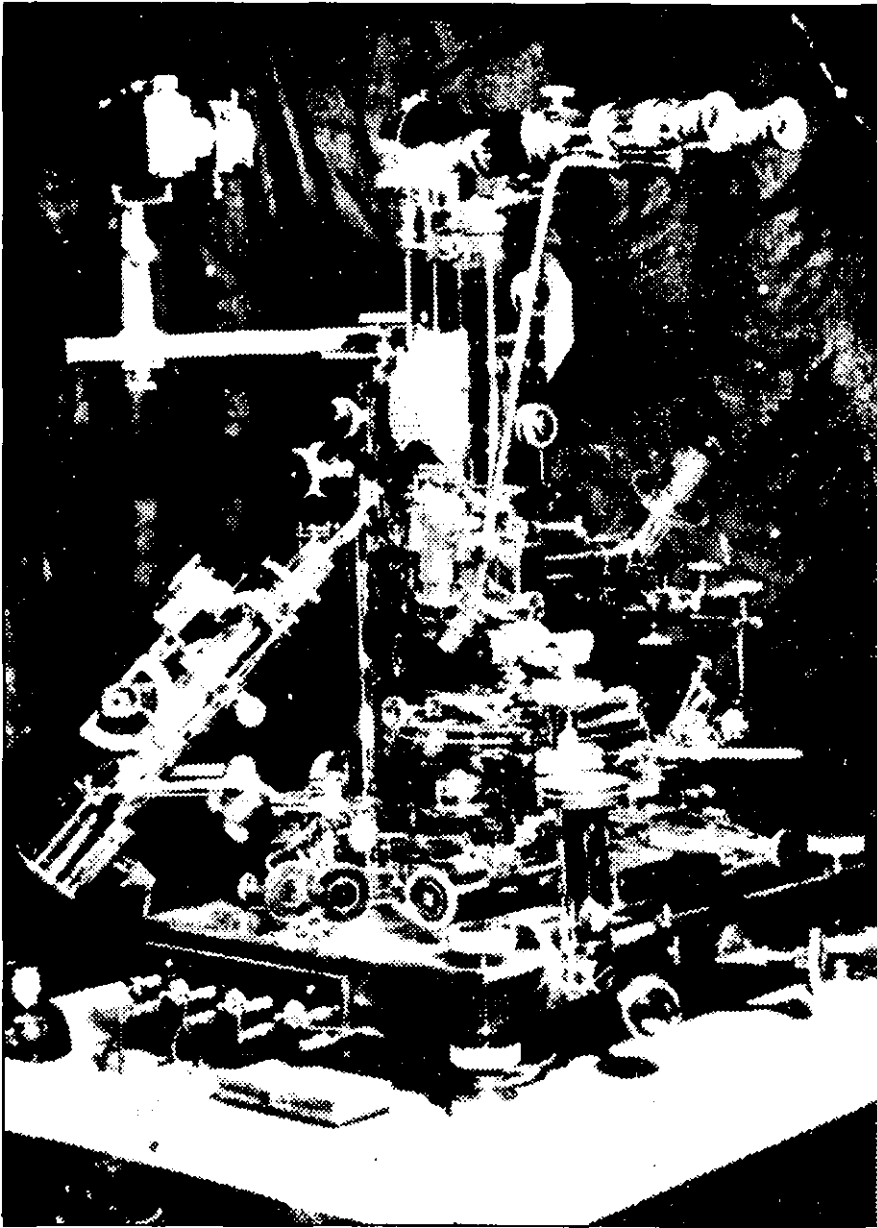

3rd Prismatic Virus "Universal" microscope, 1933.

revealed not just viruses in their dormancy. This microscope could see viruses in their active stages with magnified clarity. Dr. Rife's Prismatic Microscope surpassed the theoretical limits which were possible for optical microscopy in 1930, giving unheard resolutions of 17,000 diameters; three times the resolution developed by Dr. Lucas.

The first Prismatic Microscope was a horizontal optical bench assembly, mounted on a massive pier. Fitted with the finest photographic instruments, Dr. Rife took breathtaking photographs at unheard magnifications. The resolution was so staggering that research institutes rushed to watch Dr. Rife's demonstrations.

His accomplishments were extolled by the entire medical establishment on both sides of the Atlantic. An incredible amount of professional research publications devoted lengthy articles to his

achievements. His findings were duplicated and reported by leading medical institutes whose names are well known. Therefore our general lack of knowledge concerning his life story is equally conspicuous.

Dr. Rife, humble enough to have worked as a chauffeur, had been raised from obscurity to fame...from shadows to light. The man's genius was only equalled by the upstanding character by which he was loved. The Timkin family adored him. The Rife laboratory was completely equipped with the very finest apparatus money could buy. Dr. Rife methodically designed new research ventures. Incredible new biological discoveries followed him in every direction. Now, with this "ultra vision", he was able to peer with his colleagues into unheard dimensions. These discoveries quite often challenged accepted biological and medical notions.

Dr. Rife had in mind the creation of an Institute, in which he could train younger specialists in the operation of these wonderful ultra-microscopes. Mass production of the devices would be insured. They would become fixtures in every professional laboratory. Money was not the aim of this research. Monies were already secured. Dr. Rife had a singular goal, and demonstrated the passion associated with his quest.

He developed seven different models of this initial projection-type prismatic microscope in quick succession. The horizontal projection format was converted to a more compact vertical orientation, best serving the needs of pathologists and biologists in practical laboratory settings. Several of these wonderful Prismatic models may be seen in the various archival films and photographs taken in Dr. Rife's laboratories.

If the Rife Prismatic Microscopes outperformed every standard laboratory microscope, being able to discern and photograph virus

particles in their active state, the Universal Microscope outdid all the former records. In 1933 the creation of the Universal Microscope afforded resolutions in an astounding excess of 31,000 diameters, with magnifications in excess of 60,000 diameters.

Using technically precise photographic enlargement techniques, he was able to provide 300,000 diameter magnifications. His calculations indicated that an ultra-optical projection microscope giving clarified magnifications of 250,000 diameters would be possible. After photographic enlargement, there would be no limit to the optical viewing power unleashed for researchers.

The Rule of Abbe was mentioned as a failed byword in Dr. Rife's laboratory. He had succeeded in breaking the "vision barrier". There are those whose familiarity with optics and attainable optical precisions state that the claimed magnification effects

cannot be obtained with ordinary principles of light. Beyond simple optical parameters, other light energies become the more active in such devices. The focussing process is radionic in effect, utilizing the penetrating Od luminescence. The stimulation of special retinal modes releases the anomalous perception with its reported ultra-optical magnifications. Careful examination of the Rife Ultramicroscope reveals tubes filled with quartz prisms, identical in basic use as the patented radionic analyzers of T.G. Hieronymus (Lehr).

Viruses remained absolutely invisible to the eye when cultures were searched with the then-standard Zeiss darkfield (oil-immersion) microscope. Dr. Rife's Prismatic Microscopes were immediately obtained by Northwestern University Medical School, the Mayo Foundation, the British Laboratory of Tropical Medicine, and other equally prestigious research groups. These models produced magnification and resolution up to 18,000 diameters.

A space composed of brilliant light, where mind illuminating light merged with light in the eyes was now opened before him. Fields, all of light. The new vision would be unstoppable. No cloak of invisibility could protect the foe now. Soon everyone would see, and the armadas of death and shadow would be vanquished. The spoils of this war would flood humanity with indescribable treasure. Life and light would again be unleashed in a world where shadow and death had reigned far too long. The immense task of cataloguing viral pathogens had begun.

QUEST

With the new Prismatic Microscope models, both he and Dr. A. I. Kendall (Northwestern University Medical School) were able to observe, demonstrate, and photograph "filterable" pathogens (viruses) in 1931. Moreover, they were perhaps first to discern the transition of these bacilli from dormancy to activity over a specific period of time. Freshly made cultures were sampled at specific stages, revealing fixed periods of quiescence and activation.

An initial tissue substrate was prepared in which bacillus typhosus was cultured. After several days' growth, samples of this lethal culture were filtered through a fine triple zero Berkefeld "W" filter. This filtration process was repeated ten times. When viewed under the best available laboratory microscopes a turbidity was seen, but there appeared no organisms whatsoever.

Under the Rife Prismatic Microscope, polarizer adjusted, the bacilli in this sample fluoresced with a bright turquoise blue coloration. Two forms were observed, taking the researchers by surprise. Long, relatively clear and non-motile bacilli were found alongside a great population of free swimming ovoids, granules of high motility. The motile granules glowed in a self-fluorescent turquoise light at a magnification of 5000 diameters.

These motile forms were transferred to a second fresh substrate, and allowed to grow for days. The same filtration process was performed. When sampled randomly before the four day period, the filtered specimen revealed something remarkable. Dr. Rife and Kendall observed relatively quiescent clear bacilli containing bright turquoise ovoids at one end. The implication was enormous. Exact transition periods were thereafter determined with precision, the entire process photographed through special attachments designed by Dr. Rife. At specific intervals of activation, the clear bacilli were discharging the turquoise motile forms into the culture.

These blue ovoids were the real cause of the disease. The long and clear bacilli were only hosts. Transitions back and forth (between clear host-dormancy and motile turquoise granules) were observed and reported in the professional journals. These findings were corroborated first by Dr. A. Foord, chief pathologist at Pasadena Hospital, and later confirmed and reported by Dr. E.C. Rosenow at the Mayo Foundation (1932). The Rife Prismatic Microscope was quickly earning its reputation.

Soon, other specimens were obtained and studied by the team. Active poliomyelitis cultures were studied, the virus successfully isolated, identified, and photographed in 1932 by Rife and Kendall. In these cultures the team recognized streptococcus and motile blue forms resembling typhosus. These last reports were immediately transmitted to the Mayo Foundation and duplicated by Dr. E. Rosenow. Dr. Karl Meyer (Director of the Hooper Foundation for Medical Research, University of California) came to the Rife Research Laboratories with Dr. Milbank Johnson, examining and corroborating the stated results. The impossible and anomalous became fact. *Bacilli could act as virus carriers. Furthermore*, poliomyelitis victims evidenced a startling degree of typhosus-like associated virus.

Frightening implications came when comparisons between the Prismatic Microscope and the Zeiss scopes were made. All of the previous studies made with Zeiss scopes returned negative results. *Such reports flooded the literature. The filtrates had been maintaining their cloak of invisibility for years. Professionals, bereft of this clarified vision, were concocting numerous speculative explanations for the appearance of these disease states. The vacuum produced by lack of visible evidence was producing erroneous theories. Many highly qualified persons, in absence of the sight required to know better, steadfastly maintained that victims of certain diseases were suffering from internally developed conditions.*

The Rife ultra-microscope was about to trigger a war on viruses. Because of the self-fluorescent "staining" method, Dr. Rife observed live specimens exclusively; a distinguishing feature of his technology. The fluorescent coloration of each pathogen was catalogued, an historic endeavor. Tuberculosis bacilli appeared emerald green, leprosy was ruby red, E.Coli were mahogany colored...each wickedly deceptive in their pretty colors. The degree of precision demonstrated in Dr. Rife's catalogues bears the unmistakable mark of genius. We can view him at work in the archival movies (Ray of Discovery II).

Photographic arrays of all kinds may be seen in this footage, including the professional Scandia 35 mm movie camera with which he made stop-action films of viral incubation periods. Dr. Rife made sure to document every discovery. It was novel at the time to document every image on movie film as well as in still shots. He methodically went through every possible pathogenic specimen, photographing the deadly families. Suddenly new viral species began appearing: non-catalogued species.

The prismatic microscope was piercing into new shadows. Dr. Rife recognized unknown virus species everywhere. And then he turned his vision into the deepest shadow. He looked at the dreaded disease. To this very day the very utterance of the disease is foul. It carries the nimbus of finality. Cancer. It is an arrogant boast, a victory over cringing humanity. All who speak its name

whisper in fear, afraid that it will hear and come for them. Immigrants refused to even mention the name, fearfully crossing themselves...calling it "the evil sickness".

In the absence of fact, in the absence of vision, researchers developed contradictory theories concerning cancer and its development. These contradictory theories were eventually consolidated in the professional literature, a self-neutralizing amalgam of conjecture. Researchers were forced to examine the biochemical effects, and not the cause, of cancer. Most could not imagine what would drive cells into the bizarre and abnormal cycles common to cancer tissues. There was certainly "no visible cause".

Dr. Rife began obtaining a wide variety of malignant tissues in 1931. The full power range of the first Prismatic Microscope was turned on these tissue samples with a vengeance. Dr. Rife was a master pathologist. His techniques can be observed in his cinematic presentations. Was he seeing correctly? What were those motile forms, glowing with a beautiful violet-red coloration? He watched them for a long while. They moved swiftly through the field of view. Clocking their motility in triple distilled water, he watched them darting across the grating. These stretching ovoids moved with startling speed.

Dr. Rife obtained yet more and diverse tumors from wider and more diverse clinical sources. An amazing 20,000 of these tissue samples were obtained and cultured. Incubating and culturing each of these required care and time. Absolute sterile conditions were maintained. He employed several groups of large high pressure steam autoclaves. No question of contamination could exist in this setting. His methods may be surveyed in the archival films which show every room of his facility. Specimens, removed from these cultures were always filtered through unused triple zero Berkefeld porcelain, mixed with triple distilled water.

Examination of each separate sample under the Prismatic Microscope revealed a consistent truth. There they were again! Always the same violet-red presence. He called it the BX virus, finding it present in every case of cancer in humans. Were these same violet-red motile forms the very cause of cancer? They were always found in every sample, a deceptive beauty. Could this be the cursed stream? Had he alone been brought to see these first? Colleagues were able to verify these findings only when using his microscopes. Both Dr. Rife and Dr. Kendall successfully demonstrated the isolation of the BX virus to more than fifty research pathologists associated with the most noteworthy institutions.

Many writers of medical theory had already postulated that there were some cancer cases which were viral in origin, but they never cited these agencies as the universal cause of cancer. The speculation, the papers, the lectures, the theories. Talk and more talk. Rife saw the universal cause of cancer. There, in full sight lay the proof positive. In case after unmistakable case, Dr. Rife found the very same agency at work. Always the same violet-red motile forms. It mattered not where the tissue materials came from. There could be no mistake. There was no citing possible contaminations. Independent acquisition of tissue samples were obtained by others who then verified these findings in distant laboratories. They were using the Rife prismatic microscopes.

He succeeded in isolating the BX virus in 1931, filming the process so that posterity would hopefully learn of its enemy. He cultured this evil spawn and proceeded to demonstrate its incuba-

tion and activation periods. Transferring BX virus from culture to host, and from host to culture, all became routine. One hundred and four separate transfers were successfully made with various BX strains. Dr. Rife witnessed the appearance of another related viral cancer-causing strain, the BY virus, found to be a much larger strain of the sarcoma group. Demonstration of the infection and incubation process was subsequently affirmed by other professionals.

The same virus appeared in every case of cancer in humans. He assembled high speed movie cameras in order to clock the periods of BX virus activity. When the film ran out and was developed, he and all his colleagues could watch the deadly dance. He stepped back for a moment and surveyed the photographic evidence, flickering on the wall. Those wicked damned wriggling specks! From how many souls had they drawn away the life?

Dr. Rife now watched in horror as the malignant act was revealed before his eyes at high speed. BX virus infection required special "weakened" physiological states. Contracted as a flu-type infection, the virus incubates in host physiology for a time. When specific detrimental physiochemical states are compounded, the virus stirs into activity.

Stimulating the rapid proliferation of cell division, the BX virus forces the host body to manufacture needed nuclear material on which to further its survival. Tumors were found to be sites where BX viral colonies were rampant. Occasionally there were persons who demonstrated spontaneous remissions. These were exceedingly rare cases where antibodies actually drove off the attacking virus. Most persons could not summon this degree of response. Once the virus took control of cellular integrity, death was imminent. Shadows sweeping over humanity. There had to be a means for destroying this enemy. There had to be...a light.

SPEARS

Others, working in distant laboratories, did not claim the same success. Why had they not seen them? Because, using the over-celebrated electron microscopes, they could not see. The frightful truth concerning the BX virus was that electron microscopy could not image them at all. What had occurred in the other research labs became clear again to the man with eyes to see. The others overlooked this obvious pathogenic presence simply because their microscopes could never reveal it. This hideous specter exalted itself in what cover it could find. Unfortunately, it found cover among those who claimed to be professional seers.

Otherwise excellent researchers became completely blind when searching for the BX virus because electron microscopy was itself the blinding agent. How could so obvious a pathogen not been imaged in a technology which boasted greatest visual resolving powers? In preparing specimens for an electron micrograph, technicians "kill" the tissue specimens. The process involves placement of the specimen in a high vacuum chamber. Bombardment of the specimen with metal ions is the "staining" procedure. The thin metal film gives highly projective electrons a detailed surface upon which to impinge. The electron spray is directed into this prepared specimen and is then magnified by successive intense magnetic field coils. Images are then watched on a phosphorescent screen, or photographed directly.

Electron microscopy mishandles frail viruses. It mishandled the frail BX virus, destroying it during each preparation process.

Destroyed evidence. The same ritual was repeated a hundred times with the same negative results. Unable to think clearly, few of these technicians could surmount the situation and comprehend why this virus did not appear on their viewing screens. Over-confidence in the RCA system blocked common reason. Electron microscopy does not resolve frail viruses because they are shattered and dissolved during the preparation stage.

Well then, there was the flaw. Why would no qualified person see this simple truth? Why was the light eluding those who claimed to have all of it? The technological marvel, designed to replace all competitive microscopes had brought a secure sleep on those supposed to resolve such obvious dilemmas. Medical technicians had forgotten how to think. Its newly adopted methods actually destroyed frail pathogens intended for study.

The BX viruses cavorted and wriggled boldly before his eyes. But...how to destroy them? To find an immunological tool for each of these would represent an enormous task, a project which would take centuries. Humanity did not have that much time to wait. No, some other more universal means had to be developed by which this, and all pathogenic forms could be dissolved.

Protozoa and bacteria of all kinds could be destroyed by exposing them to special ultraviolet spectra. Perhaps the BX virus would succumb to such exposures. He had to know. He had the tool with which to see. So he began a long and arduous search, looking for spectra which could destroy virus cultures.

Dr. Rife discovered that deadly viruses actually thrived in the radiations of specific elements. Radium and Cobalt-60 were the notable ones. Dormant viruses became virulent in these energetic emanations. The horror filled him again. Medical practice was attempting the cure of cancer with these very radiations! There had to be some light spectra which destroyed the viral activity altogether.

He search through the periodic table. Electrified argon and neon also brought intensified virulent activity from dormant viral cultures. He actually utilized argon lamps to grow virus infected tissue cultures with greater rapidity. But there had to be a spectral range which killed these terrible death-agents.

No light seemed to have any effect on their crystalline structures. This is why it was possible for him to view viral activity under intense light in the first place! No light spectra of any intensity was able to destroy these quasi-living crystals.

Then he thought of crystals. How could we destroy a crystal? What do chemicals do to germs...dissolve them, take them apart...shatter them?

He had done this very thing in 1917 with protozoa and large bacteria. He knew it was possible to shatter these kinds of pathogens by the application of a sudden electrical impulse. His

early attempts with small radio transmitters and simpler microscopes proved somewhat effective. He used Telefunken output tubes to produce the impulses. Operated by a small generator, this simple device projected fifty radio frequency watts to his samples.

His original inspiration applied to larger pathogens. It therefore needed no excessive frequency, short wave being sufficient. It was certainly possible to interpolate the necessarily superhigh resonant pitch needed to shatter any microbe. But viruses? How high would this pitch need to be? If not attainable, could he use some much lower harmonic of this fundamental at greater power levels? Could he find the lethal pitch for every found pathogen?

Equipment was quickly assembled. He needed a generator of extremely short duration electro-impulses. Direct current electrical "spikes" of quick duration, when applied to a gas filled discharge tube, would project electric rays toward an infected sight. The tube could not be a simple high vacuum. That would release dangerously penetrating X-Rays. X-Rays would stimulate the BX strain into increased activity. No, the projection tube required a very light gas, one whose response was almost instantaneous. The gas he desired would be one whose mass would in no way interfere with the impulses.

Hydrogen was used in special high power thyratrons: quick acting high voltage switches used in diathermy machines and (later) in radar systems. Old X-Ray tubes often failed in their operation because they became filled with hydrogen and helium mixtures. Such X-Ray tubes were generally discarded. His new projector was one such old X-Ray tube. He tested its output, adjusting the excitation circuit so as not to release even soft X-Rays. The tube glowed, a good sign. This meant that there was sufficient gas for the release of electrical rays. Dr. Rife set the polarity

so that the tube would pulsate in electropositive spikes of specific duration.

Power was ready. Pathogens cavorted boldly in view. Poised at the Prismatic Microscope, he fired the X-Ray tube. Turning the tuning dial near the specimen, he would know the lethal pitch by watching the pathogens. When these "exploded" he would mark the setting. If this method worked, then he could methodically correlate each lethal pitch with its pathogen. Soon, a catalogue of lethal pitches would be amassed. With this Dr. Rife could wage victorious wars against every disease in existence.

Dr. Rife swept through the diathermy range, which he calculated should vibrate these viruses to pieces. Empirical evidence always contradicts the theoretical. Quite below the calculated extreme frequencies, the BX virus suddenly dissolved. He switched off the transmitter and sat there quite amazed. The scene in the

In a final amazing experiment, he took cultures away from the laboratory in sealed containers. It was found that radiant tube emanations operated effectively on viral cultures up to an eight mile distance!

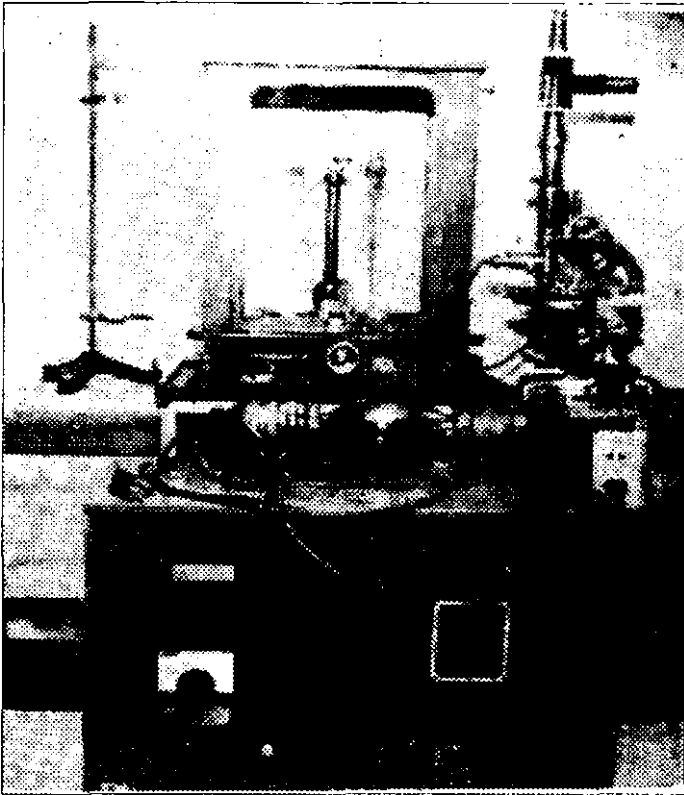

Ray tube instrument, c. 1954

microscope was unreal. Not a fraction of a second at the lethal pitch and the specimen was reduced to a glomular mass. The viruses were stuck together in shattered fragments! He had successfully "devitalized" them.

Fine tuned lethal frequencies now filled his catalogue. With great precision Dr. Rife determined every lethal pitch as planned. Armaments of light against legions of shadow. Analysis of the electropositive impulse showed that its radiance was penetrating, intense, and unidirectional...more like invisible light rays of pure electric force. What then was this strange lightlike power? Experiment proved that virus cultures were absolutely incapacitated, congealed, and destroyed by the electropositive impulse. The power of an extreme form of light? Had such light ever been seen before?

This energy had been accidentally generated in 1872 by Thomson and Houston. Not waves, but rays. Electrical rays. A forgotten phenomenon. Unidirectional electric impulses of great power radiated electric rays, not waves. These rays penetrated all kinds of matter, whether stone and steel alike. The resultant sparks could be drawn from every insulated metal object in the large building in which the experiment was being performed. Not radiowaves, but electric rays.

Later in that century, Nikola Tesla accidentally observed the same electric ray production. He studied the phenomenon exclusively, developing impulse generators and electric ray projectors. When speaking of electric rays which evidenced a light-like nature he referred to this phenomenon. Not radiowaves, but electric rays. New light. Dr. Rife had rediscovered this phenomenon. Tesla

spoke of his own "millimeter rays", mentioning their "bacteriocidal" value. This same phenomenon had vindicated Tesla's words. Therapeutic properties were demonstrated when precisely controlled.

FORTRESS

Whereas the destruction of virus cultures on a quartz slide was easily accomplished, the destruction of pathogen cultures in human hosts was not. Rays had to penetrate through skin, musculature, and bone; a considerable resistance through which to travel. Rays might lose their original accurate pitch in this transit, destroying the intended action altogether.

Fortuitous and strange, the pathogens were found to be some two thousand times weaker than body cells. This meant that pathogens could be destroyed by the radiant impulse method without harming the patient. How sublime. Pathologists had treated micro organisms as chemical systems for a century, working overtime in order to find each specific chemical dissolving agent. This method treated all germs as mechanical systems, dissolving them with vibrations.

He himself had been exposed to the instantaneous blast without harm. When adjusting the rates to annihilate ordinary viral infections, he noticed that he became drowsy and tired for a few hours. Determining the cause of this as the resultant toxin release after infective agents were coagulated, he recognized the need for a de-toxifying agent. Physiology had to be prepared for the curative impulse. Exposure would release large amounts of toxic pathogen fragments into the bloodstream all at once. The ray cure had to be metered in doses. Body tissues had to be flooded with special fluid electrolytes to aid the enhanced and rapid elimination of these toxins.

To stimulate deepest shattering action, the patient had to be bathed in a "carrier field": an electrical body permeation in which the impulse light rays could penetrate into and through every body cavity. Superficial exposures would not completely cure the patient. This light ray energy had to permeate the body completely. Dr. Rife conceived of method whereby patients could be enveloped in a harmless body-permeating electric field of acoustic frequency, while the intense electro-impulses of short duration would be simultaneously projected. In this manner, efficacious electro-radiant impulses could shatter specific pathogens throughout the infected body with no harm to the patient.

Dr. Rife utilized two banks of oscillators with which to generate his primary and secondary impulse fields. Acoustic generators supplied the primary field of "immersion". A diathermy machine was coupled to a powerful transmitting amplifier to provide the shattering impulse. Two radiant energies were thus employed to destroy pathogens in vivo. Dr. Rife's catalogue of lethal rates always gives a pair of lethal frequencies per pathogen.

Dr. Rife discovered that virus cultures were not safe from the radiant impulses from the special ray tube. Fixed to the lethal pitch of a single pathogen, the rays were unerring in their message. Selectivity was the hallmark of the Rife curative method. Several pathogens could be assembled adjacent to one another. Choosing the lethal pitch for one of these, the others would remain unharmed. The target, however, was utterly destroyed.

Dr. Rife tested the lethal effective distance of his rays, determin-

ing the safe placement of patients from the radiant source. Pathogen cultures did not seem "safe" anywhere near the device at all. Arranging the tube at one end of his laboratory, Dr. Rife brought cultures out to increasing distances from the radiant tube. In a final amazing experiment, he took cultures away from the laboratory in sealed containers. It was found that radiant tube emanations operated effectively on viral cultures up to an eight mile distance! Metal cabinets did not protect viral cultures from the deadly ray effects either, being ray conductive. Even when locked in aluminum cabinets, the entuned light-like rays destroyed their pathogens wherever found.

This represented a major medical discovery of greatest value to all humanity. This principle actually made possible curative broadcasts. Entire populations could be electrically "vaccinated" from single monitored sites. The world potential of this system was staggering. Now the outbreak of epidemics could be controlled without the time-consuming need for individual inoculations. The radiant lethal message would eradicate specific pathogens in several simple broadcasts. The constant monitoring of socially prolific germ populations could be maintained by continual public health "broadcasts".

CONQUEST

He ran his entire staff through varied frequency exposures. Infections of all kinds each dissolved before The Ray. Dr. Rife was able to isolate the pathogens of infection and destroy them with the mere turn of a dial. The specificity of the raytube device was so precise that singular germ strains could be individually mass-targeted. Cured by the flick of a switch!

Firing the tube in the lab provided a continual source of inoculation. After a time, so little toxicity was present in staff members' bodies that the drowsy effects were never again encountered. They did not contract any illnesses. Not even colds.

After a time, Dr. Rife rarely used gloves when handling the viral specimens. Furthermore, neither he nor his technicians ever contracted any of the diseases which were handled. The Raytube "inoculated" them all against every disease. He reported these findings to the community, while himself remaining the designer and developer of the system.

Dr. Rife, a research pathologist, never used these devices in medical practice. Other physicians desired the units for their own purposes, recognizing the potential for curing human suffering. Dr. Lee De Forest supervised the design and assembly of many oscillator components for the Rife System. W.D.Coolidge himself (General Electric) willingly sent Dr. Rife hundreds of X-Ray tubes which were altered with a mixture of hydrogen and helium by Rife and his technicians. These improved tubes were tested so that they would project only the desired electro-impulse rays. These noteworthy references best recommended the Rife Raytube System to medical practitioners of the day.

Hearing of these wonders, numerous physicians began requesting that smaller, more portable units be designed. Soon, Rife Raytube devices were being assembled and given to physicians for limited use in their own practice. When properly operated, these devices returned successful reports, effecting complete eradications of infections and cures of various conditions. There were never any adverse reports concerning the Rife Raytube Instru-

ments. Neither could there be. Rated at such safe peak performance levels, no harm could possibly come from the portable devices.

The careful and reasonable monitoring of patient progress, the Rife frequency devices were bringing about a therapy revolution. Strep throat could be cured in an instantaneous exposure, seated in a physician's office. A specially designed gargling solution was given to remove the resultant toxicity from the site.

In 1934 Dr. Milbank Johnson, Chief Medical Director of Pacific Mutual Life Insurance Company, established a therapy center for cancer treatment in Scripps Castle, San Diego. A staff was brought together from specific institutions including Dr. G.Dock (Professor of Medicine, Tulane University), Dr. C.Fischer (Children's Hospital, N.Y.), Dr. W. Morrison (Chief Surgeon, Santa Fe Railway), Dr. R.Lounsberry, Dr. E.Copp, Dr. T.Burger, Dr. J.Heitger, Dr. O.C.Grunner (Archibald Cancer Research Committee, McGill University), Dr. E.C.Rosenow (Mayo Clinic). Dr. Rife functioned as a general consultant in matters of system therapy.

Using a Rife Raytube system, the team received cancer and tuberculosis patients. Fifteen cancer patients, each pronounced hopeless by medical experts, arrived at the clinic. Each evidenced progressive states of the disease. A few patients were ambulatory. Treatments with the Rife Raytube method were routinely applied. The dream was becoming real. Humanity was at last receiving its help.

Recognizing the critical condition of their patients, it was decided that exposure time would be raised to three minutes duration. It was discovered that exposures could not be repeated daily without necessary long rest periods. These critically ill patients could not withstand the extreme resultant toxicity released into the system as BX viruses were shattered. Emotional depression often resulted until the ray-dose was safely assessed. The team conferred hourly to assess the progress of each patient. Excessive exposure to the rays could result in severe lymphatic infections and blood poisoning. Therefore three minute treatments were repeated every third day, the rest periods necessary for blood detoxification.

Soon, the ray had done its work on the once-terminal victims. Constant blood and tissue samples revealed no BX viral presence in these now fortunate individuals. In sixty days' treatment time, and after examination by several physicians, each was released as cured.

Though under continual surveillance, no relapses occurred. The treatment was revolutionary. The results, thrilling and complete. Moreover, they were confirmed by a special medical research committee of the University of Southern California. Three more clinics were opened with Dr. Johnson as General Medical Supervisor. Other participating physicians included Dr. James Couche, Dr. Arthur Yale, Dr. R.Haimer, Dr. R.Stafford with a mounting number of participating physicians. Clinics were operated between 1934 and 1938 having such a number of cures that it is difficult to list them all without simply reprinting the Rife files. Each of these cases were sent out and corroborated by other (non-participating) physicians.

In 1939 Dr. Rife was formally invited to address the Royal Society of Medicine, which had recently corroborated his findings. He was requested to bring all possible films, slides, and apparatus with great enthusiasm. Dr. R. Seidel reported these findings and

formally announced the Rife Raytube System therapy for cancer in the *Journal of the Franklin Institute*. (vol. 237 no.2 February 1944).

The formation of the Ray Beam Tube Corporation was announced, through which several models would become available to the medical world within a short time. Highly skilled hospital staff members and leading physicians were very receptive to the proliferation of this therapy. Here was a new means for controlling and eradicating any kind of disease by the press of a switch. This therapy would inadvertently challenge pharmacological methods, raising human standards to a new and lofty height. The dream seemed ready to materialize.

INQUISITION

Rife found both himself and his staff members under a strange series of attacks by unknown agencies. During this time, and under very mysterious circumstances, Dr. Johnson died in a hospital bed. Brought there for completely minor reasons, he was found in bed. The local chapter of the Medical Association proceeded to bring Dr. Rife to the San Diego Supreme Court, but lost their case (1939). Dr. Rife could not be charged with malpractice, being a research pathologist and designer of medical instruments.

This repugnant offense unmasked the heinous resentment behind which many powerful individuals had previously been camouflaged. The court action itself caught Dr. Rife quite unaware. A visionary, his entire life had been dedicated to humanity. Alleviating human suffering was his life theme. Here now was strong evidence that factions within the Medical Establishment were actually mobilizing against proven therapeutic methods. Cancer itself and other equivalent maladies were being cured. Why then the assault?

Growing opposition from deeper factions of the Medical Association brought pressure on Rife Treatment clinic staff members. Threats and other unprofessional pressure tactics forced members to leave the team in quick succession. In campaigns clearly waged to malign Rife and his findings, the Medical Association assailed remaining participants in the clinics until Dr. Rife stood alone.

Deeper than the verbal show of malignancy by other colleagues was the horrifying and insidious motivation, the implication behind the attack. Why would anyone wish to destroy so great a world-advancement? Who was betraying civilization in this critical instance? Of all betrayals and of all personnel, who in the Medical Profession would seek the eradication of such monumental discoveries? Dr. Rife's mind reeled under the weight of these thoughts. This was not mere resistance to a new idea in a time of ignorance. Pasteur experienced that indignity. No. This was a willful, calculated resistance in a supposed enlightened time.

Horribly shocked at the entire scenario, Dr. Rife literally became unhinged in court. Trembling and weeping, he could not come to terms with the sheer hatred and vehemence exhibited by his antagonists. "Why...why are you doing this?" he repeated. The prosecution could not have produced a better effect. Seeing this weakness as the very means by which to eradicate Rife and his discoveries, they continued to attack Dr. Rife openly. Calling him continually to the witness stand, they succeeded in destroying this frail hearted man of humble greatness. In short, the prosecution forced his total collapse.

Dr. Couche was compelled to desist operating Rife Therapy

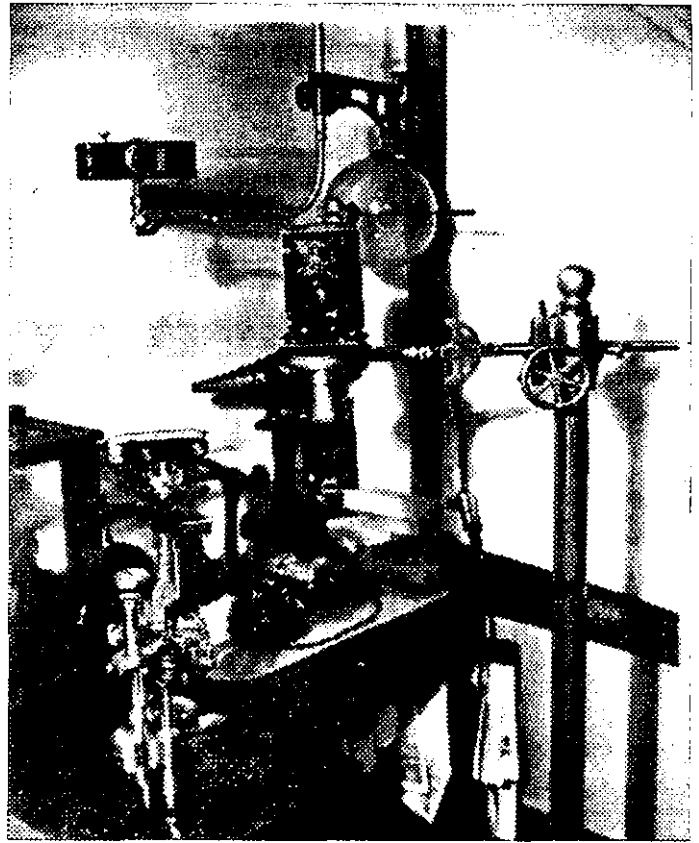

From the laboratory of Royal R. Rife, 1930.

clinics under threat of malpractice. The Medical Association ruled that no society member who maintained use of the Rife Raytube System would be permitted to continue medical practice in the United States. Morris Fishbein, major AMA stockholder, treasurer, censor, editor, and controller extended his legal arm to inform each member of the Rife team of the impending legal process. All Raytube units would be recalled, impounded, and destroyed by Federal Court order, under penalty of fines and imprisonment.

LIGHT

All participants willingly returned their Rife units except Dr. Couche and Dr. Yale. These two surgeons later stated that for twenty-two years after this action, they continued to successfully treat and cure thousands of patients with the Rife Raytube devices which they secretly maintained. Dr. Yale published a large and concise chronological account of patients treated and cured in his practice throughout that twenty-two year period. Notwithstanding the fact that sixty percent of severe (cancer) cases brought him were medically inoperative, incurable, and hopeless, Dr. Yale confirmed that all of these persons were yet alive and living happy, full lives.

The Rife Microscopes challenged RCA and its lucrative electron microscopes. The Rife Raytube System would eradicate the accepted lucrative pharmacological methods everywhere. Such developments did not inspire challenged corporations. Dr. Rife developed a therapeutic means which works. This is all too evident

by the rage of those who assailed him.

Systematic eradications of this priority level speak of social control on a vast and hideously deep-rooted scale. Implications necessarily involve corporate trusts and governmental agencies. The notion that disease proliferation is permitted for the continuance of pharmaceutical interests is too terrible to reasonably consider. Federal Officers came to impound the entire Rife laboratory all too late. Several faithful technicians had already purloined every piece of the priceless equipment, taking laboratory components and valuable documents across the Mexican border where they yet remain.

Fishbein, the editor and chief censor of the AMA saw that Rife's name would be stricken from all previous publications, that no professional journal would dare publish anything by Rife, and that no mention would ever be made of Rife's achievements in formal proceedings. Inescapably linked with the pharmaceutical trusts, Fishbein's actions were all too conspicuous.

Social control has become a dominant theme since the second World War. Modifying and regulating social thought through both legal and financial steerage has brought natural discovery and true technological development to a standstill. World changing discoveries can be made but not proliferated. Cures for diseases can be proven, but not implemented.

Has the world now entered a new barbaric and vulgar time where medical wonders have become a regulated property? The historical evidence proves out these thought lines. Balancing profit against cost, it is clear that outright cures are far less profitable than exceedingly prolonged and profit-effective "treatments". Statistical analysis of social "disease incidence" mark the yearly expected gross earnings, a profit margin of untabulated measure.

Would the honor once laid upon the development of wondrous disease cures now be shunned, the cures themselves being suppressed at will by business managers? Would compassion for suffering humanity, concern for the elevation of human living standards on a worldwide scale no longer be a major medical theme?

World Society is driven by the unmodified flow of natural scientific discovery. At the fundamental level, such discoveries are truly socio-providential. While previous epochs simply endorsed and socialized each new natural discovery, newer attitudes have suffused the world from financial "sites of infection".

In the past, medical discoveries were never questioned or resisted. They were always looked upon as absolutes: if a medical cure for disease was found, it was taken as it truly is...a miraculous providence. Not even the most ruthless financier would dare interrupt the flow of medical discoveries in past times. This state of ethical acumen has not continually been honored.

When the records are actually examined, when the billions of research dollars have been computed and balanced against the true research effectiveness, we find a staggering disproportion. How is it that medical research of the nineteenth century, far less equipped and funded, produced definitive cures which have become medical "standards"; while contemporary medical research, best equipped and super-funded, has not produced a single cure of equal social importance in the last thirty years? Dr. Rife had the answer toward eradicating all virus potentials. Perhaps, because it was not a pharmacological one, his devices have been

"legally restrained" from social proliferation.

A few moments' calculation reveals the effective ability of research to find a chemotherapeutic vaccine against each deadly virus. The calculated time exceeds several millennia. But Rife found the only reasonable technique for destroying any virus infection at will. The answer was not a pharmacological one. Eradication of his techniques at this early stage of development would be reasonable if one were heavily invested in chemotherapies. The systematic eradication of many such (recorded) cures is revealing.

Medical authorities have stated that "no means has been found by which viruses may be destroyed". Recent evaluations of "recaptured" Rife Raytube units contradict this statement. Dr. Rife treated germs as mechanical systems, not chemical systems. Vibration killed pathogens by the flick of a switch. A single such device could be easily tuned to destroy all deadly pathogens. His is the only device which can destroy viruses.

UCLA Medical Laboratories, Kalbfeld Lab, Palo Alto detection Laboratory, and San Diego testing Lab all had stated that the Raytube System is absolutely safe to use. The FDA went out of its way to publish and maintain Federally directed rulings on the Rife Raytube System, refusing to make further statements concerning its historically proven effectiveness in thousands of cured cancer cases.

A great gathering of esteemed colleagues of the medical and research professions came to honor and support Dr. Rife after the entire court affair. Friends who were too frightened to stand and fight at his side were now smiling, drinks elevated. But the man who was asked to stand and receive honor saw through the charades.

The seer saw the thick shadows which enveloped the professionals and other dinner guests. Armadas of pathogens were drumming their war drums again. Soon on the march, they would devastate humanity once again. It seemed that not one of the esteemed guests cared. The Rife Raytube Therapy was the only time in history that viruses could be selectively and dynamically destroyed. No chemotherapeutic agencies were ever required in the process. The mere closing of a switch could achieve these undreamed wonders.

Dr. Rife had developed and implemented what no contemporary medical research group has ever conceived. And, by the end of World War II, was prevented from ever doing so again on American ground. The cheers and accolades rang on, while standing ovations lasted for more than fifteen minutes. The now frail and ghostlike discoverer looked away. Far off and away. Searching through the shadows, searching in his own darkness...for new light. ■

GERRY VASSILATOS began writing for *Borderlands* magazine several years ago. He is the producer of the *Ray of Discovery* video documentary series, *Aura Motors*, *Earth Tones*, and is also the author of the *Vril Compendium* — a borderland research encyclopedia which now totals 11 volumes. As an avid experimenter, Mr. Vassilatatos has contributed to several advancements in the fields of Radionics and energy research. This is his fourth biography in an ongoing series of the borderland "greats".

Tai Chi Qu'an 24 Movement Form

with Master Lei Li

New!



In this one-hour video, Master martial artist Lei Li teaches the introductory 24 Movement Form of Tai Chi Qu'an. Tai Chi can be considered the "radionics" of body movement, and has been proven to relieve stress, increase mental and physical energy, and develop muscle tone. The slow, rhythmic movements provide all the benefits of a rigorous workout, without the potentially harmful side effects. Here, Master Lei Li guides you through warm-up exercises, basic footwork, and the entire 24 movement form, step by step.

"Lei Li is simply the best martial arts instructor I've ever personally trained with, and this video is a testimony to his great teaching ability." — Michael Theroux



Tai Chi Qu'an with Master Lei Li
#V0046, VHS Video, 60 mins., ... \$29.95

AURA MOTORS

with Gerry Vassilatos

New!

Author, researcher, Gerry Vassilatos takes us on an experimental tour of the Aura Motor, or Auric Engine. The Aura Motor is simply a metal vane balanced on a pivot point, and has been used for years to demonstrate psychokinetic ability. These unique devices have received little exposure in recent years, until now. In this video, Gerry not only affirms the capability of the aura to move the vane, but equally fascinates us with demonstrations of the vane's reaction to various substances. His insightful commentary is filled with historical references, and gives us a renewed awareness of the power of auric emanations. This video is sure to be a classic in the field of borderland research!

AURA MOTORS, #V0047, VHS Video, 30 mins, ... \$19.95



**Borderland Sciences Research Foundation P.O. Box 220 ★ Bayside ★ California ★ 95524
or call 707-825-7733 to place your order by credit card. Please include \$4 for p&h.**

INTERSTELLAR

COMMUNICATIONS SIGNALS

by L. G. Lawrence

Field Manager, Ecola Institute

Reprinted from the July-August, 1973 issue of The Round Robin

THE possibility of life beyond Earth tends to evoke partisan emotions denoting two extremes (1) that life is unique to Earth, and (2) that it is ubiquitous and abundant throughout the universe. Hints about life elsewhere have been vague, including "organised elements" in meteorites, Martian infra-red spectra implying organic molecules, and the rare non-random radio signals whose reception was claimed by Tesla and Marconi. Yet a psychological readiness to accept extraterrestrial life has emerged to a most profound degree.

Divorced from its science-fiction background by Project Ozma in the early 1960s, the topic is now formally called "communication with extraterrestrial intelligences" (acronym CETI). It was the subject of a top-level international conference held in September 1971 at the Byurakan Astrophysical Observatory in Soviet Armenia. The meeting was sponsored by the United States and Soviet Academies of Science. Similar interests prevail in private study groups both here and abroad.

Such programs must be welcomed in behalf of all mankind. For interstellar communication with other, highly advanced cultures might well determine human progress and survival. Thus, by inference, CETI emerges not only as the greatest adventure of mankind, but also poses a colossal challenge to systems engineering.

It remains an unfortunate fact that the majority of ambitious CETI programs continue to be aligned with the somewhat obsolete theories and hardware of radio astronomy. This is a serious drawback for several reasons: (1) local inadequacies in interstellar communications technology and humanness are imposed upon a given extraterrestrial society (prompting it to lose interest in us), and (2) we must be aware of the pre-eminent possibility that Type II or III civilizations — whose worlds were old when Earth was young — no longer employ electromagnetics-based

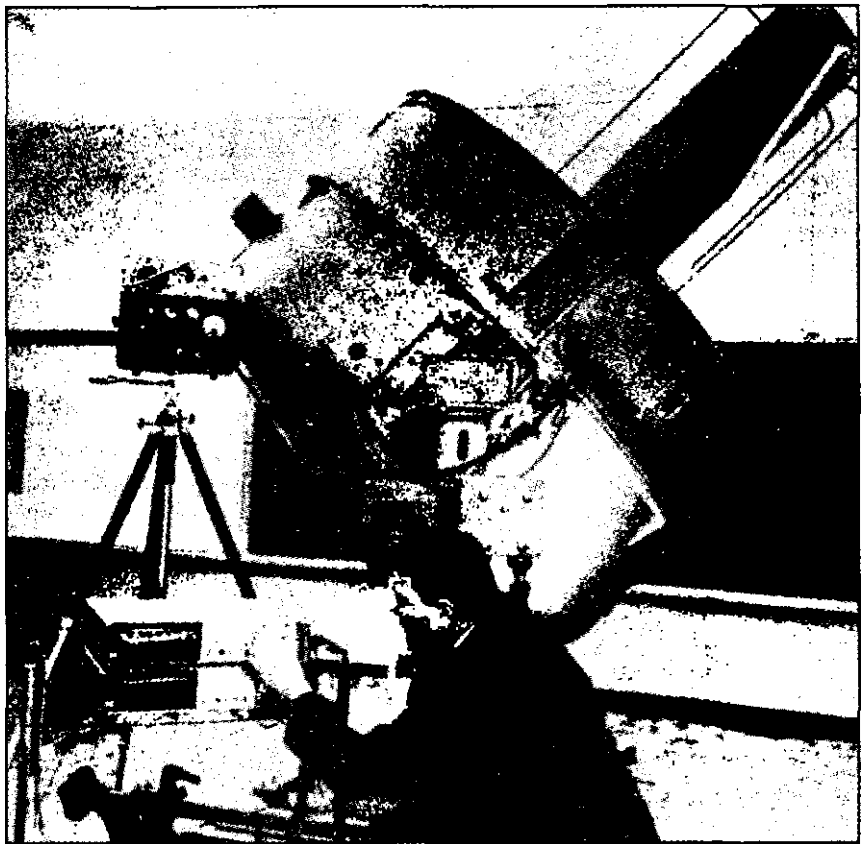

Lawrence's Astrobiological research instrument, a radiotelescope with biological sensors, mounted on a pan-azimuth yoke assembly.

communication technology due to obsolescence. The latter assumption is defensibly supported by the fact that terrestrial radio astronomy, in its 40-year-long history as an electronics-based science, has failed to detect intelligent, non-Gaussian signals from deep space.

A somewhat better, more promising outlook has emerged as the result of experimental data obtained by our Institute. The inference has been drawn that interstellar communications signals,

as presumably are interchanged between peerage groups, are of a biological rather than electromagnetic – nature. If verification tests continue to be affirmative, it will explain the aforementioned failure of traditional radio astronomy.

COMMUNICATION BY ACCIDENT

As one frequently encounters in exploratory research, our CETI-type data was incidental to other work and not sought for. We operate a mobile field laboratory. One of our objectives is the development of non-polluting electronic alternatives to chemical fertilizers and pesticides used in agriculture. Special investigations are directed at behavioral plant electrophysiology and bioelectric phenomena associated therewith. Viable organic transducers have been evolved, profiles of which were given in (1) *ELECTRONICS WORLD*, New York, October 1969, pp. 25-28, and in (2) *ELECTRICAL REVIEW*, London, June 2, 1972, pp. 780-81. Composite techniques have been adapted for field research in remote biological sensing (RBS), which allowed discovery of the following phenomena.

On October 29, 1971, 20:30 PDT, while conducting exploratory RBS experiments in Riverside County, California, our field instrumentation's organic transducer complex intercepted a train of apparently intelligent communications signals (tight spacing and discrete pulse intervals) while accidentally allowed to remain pointed at the constellation Ursa Major during a short rest period. The phenomenon prevailed for somewhat over 33 minutes, approximately 30 minutes of which were recorded on tape when the

audio monitor drew our attention.

A somewhat similar phenomenon was observed on April 10, 1972, 22:30 PDT, while conducting experiments in the Mojave Desert, California. Other, fragmentary interceptions have been made in the interim. The apparent signals, aside from seemingly growing weaker, appear to be transmitted at great intervals ranging from weeks to months, possibly years. A faint, coherent, binary-type phenomenon was noted during aural monitoring' using equipment such as shown in the accompanying illustration. Intervals between rapid series of pulse trains ranged from approximately 3 to 10 minutes. It is likely that other phenomena have escaped detection, since lack of special facilities and resources precludes routine monitoring at this time.

Because our equipment is impervious to electromagnetic radiation and found free of internal anomalies, the tentative conclusion of biological-type interstellar communications signals has emerged. We also entertain the possibility of an emergency transmission (here directed at peerage societies only), since relatively large power levels of given makeup are required to overcome bioelectric impedances and galvanic network losses inherent in our developmental instrumentation. A two-way transceiving capability has not yet been achieved.

Data contained in our October '71 tape was accrued via analog DC-to-AC conversion techniques. Here, fluctuating DC signals, as generated by organic semi-conductors in the transducer complex during signal incidence, are made available for direct audio recording by changing DC products into variable-pitch audio

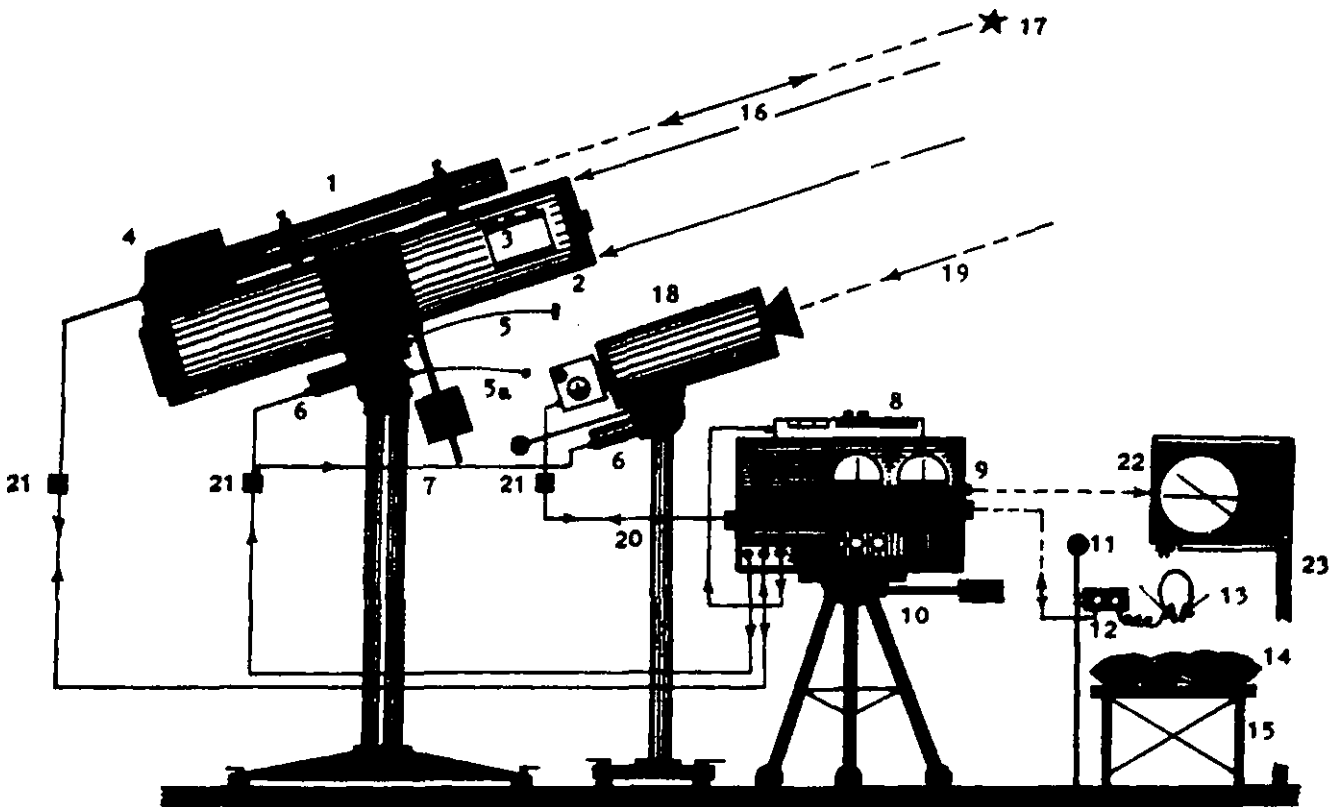

- Fig. 1 -



Windmills of Light

A Short History of the Radiometer

by Franklin Ellsworth Clarke

A GREAT controversy once raged in European academies concerning the nature of light. While many held to Huygens' wave-model, some believed that light also contained a very fine particulate component. A particulate haze theoretically accompanied each wave of light, causing the effulgence usually observed at dawn or dusk. This particulate haze necessarily differed in content and nature with source, being thrown out of radiant objects as an explosive cloud.

In this model of light, physicists eventually found themselves searching for a gaseous æther. Numerous writers hypothesized that such clouds of light particles formed an interstellar ultra-gas, one whose presence should be shown through simple force actions. Therefore, proofs of the ultragaseous æther were sought in countless failed quantitative experiments.

Qualitative experimenters had already satisfied themselves that light contained a component, whose nature was vivifying and not inertial. Thready and self-luminous in nature, an essential unity was observed among celestial light sources and the human aura by notable and rare academicians such as Baron von Reichenbach. His qualitative experiments employed the delicate human sensitivities which academicians disqualified.

These thready auric energies were not electrostatic or magnetic, and this created a furor in the universities. Disbarring the human sensorium, there was no inertial means for proving the existence of aura. And here was where quantitative science first challenged the

very validity and worth of qualitative science in a unified assault.

CROOKES

Sir William Crookes (1832-1919) was an aficionado of Reichenbach, studies which proved the essential integrity and living nature throughout nature. These views were formally espoused by Goethe in a thesis comprised of much older views, the compiled inheritance of old knowledge. Sir William was convinced that the world-foundation was a spiritual one, and that life was derived of energetic emanations proceeding forth from this sparkling and vivifying "astral" foundation.

In essence, Sir William believed that the physical world was undergirded by a living infrastructure from which all life, here and beyond, was drawn in a steadily pulsating flow. To this end, Sir William conducted experiments designed to reach through the veil which separated the two homogenous worlds. Through his varieties of electrostatic devices, he wished to reach through the inertial walls and touch the "astral" life source itself.

The Crookes Tube was designed to peer into "astral" space beyond the inertial walls. Using electrostatic tensions in order to shear inertial space open, Sir William and others spent long hours making observations of tran-

sient forms which appeared with great regularity in his "astral detectors". It was here that he discovered the famed "dark space", a region where all luminosity ceases, being replaced by a spreading black radiance.

When this black space appeared, a sensation of effortlessness also appeared in the room, an ease of thought and an uncommon extension of conscious states. This black radiance was not a terrestrial experience, having power to modify sensation and extend consciousness. Sir William believed this to be the very "astral foundation" torn free of all inertial bonds, and radiating into terrestrial space through his tubes.

In this awareness, later Crookes Tubes took on a decidedly occult appearance. These were large, globular, and contained concave mirrors. Sir William was often photographed carrying one such large globe in various angles of inspection. These large discharge devices were designed for group observations, being taken to various locations and used to examine spaces where free floating ectoplasms were reportedly observed. In effect, what Sir William had designed now was used as a ghost lamp! Others have since described similar experiences and effects associated with strong electrostatic impulse discharges (Gaddis, Dollard, Theroux).

THE CROOKES RADIOMETER

During the course of these developments, Sir William undertook an experimental arrangement which would provide yet

another proof of the "astral world" and its emanations. Light, he imagined, was a natural electrostatic tension across vast distances of inertial space. Here, the radiant black astral world would be very nearly exposed. Being exposed so directly, its energies were capable of being harnessed for work. Channels of black astral radiance were necessarily also core-like channels of great ætheric effulgence, foci where inertial space was dissolving and vital energies were appearing. Starlight and sunlight would serve as the best sources of this "astral radiance".

Designing what he called a "light mill", Sir William attempted to draw motive power directly from the "astral" cores of lightbeams. The "light mill" was a device designed to be propelled by light beams which surrounded astral channels. A radial fan of thin mica vanes, each silvered on one side, was supported upon a rotating pivot of vanishingly small friction. Like the Crookes "astral detector", this *light mill* was housed in a very highly evacuated glass globe. He named this device the "Radiometer".

Deciding that a reflectivity should "tip the scale" of these decidedly frail forces, he coated one side of each mica vane with silver. Light particles, flooding the space where waves flowed, would now reflect and rebound away from the silvered vanes. The effect of this reflectivity would be transferred as kinetic force. The high vacuum within the globe would offer both light particles and mica vanes no opposition to rapid movements.

Momentum by "light pressure" alone, would push and propel the little fan of mica vanes as light-associated particles bounced off the silver coatings.

The globe prepared, light was directed onto a single silvered side. Nothing happened. The vanes refused to rotate. Sir William was completely baffled. This greatly puzzling mystery gripped academic minds everywhere. The inertial æther theory had met its first great impasse. Demanding the quantitative proof which it declared only valid, academicians discounted all but inertial proofs of the theory. Ultimately desiring the complete overthrow of any theory which included the very word "spirit" or "soul", quantitative science found its first opportunity to gain pre-eminence.

After sufficient meditation, Sir William re-designed this original Radiometer. In this second design, vanes were coated on both sides with dissimilar materials. Silver sides were backed with an opposed coating of lampblack. According to the theoretical considerations, æther particles would reflect and bounce away from the silver, giving up their kinetic energy and driving the vanes forward. Absorbed by the opposed lampblack coating, the vanes would be drawn into particle flow, doubling the force. The resulting force-couple on each vane would theoretically multiply and compound the motive effects.

The new Radiometer carefully prepared, light was applied to the silver vane-faces in a tight beam. But a profound and remarkable anomaly was then observed. The vanes were indeed set into a whirl, but rotated in a direction opposite to that which theory demanded!

Vanes were repelled by light on the lampblack coated sides, while being drawn by the silver coated sides. What was this effect? How was this motion, strong and continual under the light, being produced? It was clear that light-pressure was not the cause of this movement, but what actually caused this movement?

Astute academicians declared that gas particles, and not light

itself, was responsible for the vane-motion. According to their analysis, a swarm of gas particles near the lampblack were being heated by impinging light particles and absorbed by the vane. High velocity gas particles were brought against the black walls. There, the exchange of kinetic energy caused them to rebound off the vanes. Motion was the result.

The opposed dynamic supposedly took place at the silver coated sides, where swarms of gas particles could bring neither the vane nor the gas to an equivalent heat. This region supposedly became a rarefied one, drawing the vane into the relatively vacuous space.

Crookes and others were not sufficiently convinced of this explanation, there being numerous and obvious flaws in the argument. At certain point the glass-insulated rotor would have to cease moving. This would occur when once the enclosed gas became of a uniform heat. The vanes, no longer able to absorb any extra energy from the light, would cease.

This is not what Crookes empirically observed. Highly insulated Radiometers continued rotating with constant speed under full sunlight! It was also pointed out that the Radiometer should have best operated in a full atmosphere on a jewelled bearing, where an increased gaseous plenum would have supplied a greater population of gaseous kinetic carriers for motive power.

But Sir William found the Radiometer operated best at a very specific lowered atmospheric pressure.

The disheartening fact that light itself could not propel the vanes was added to the equally disturbing fact that highest Radiometer vacua produced no vane rotation. Crookes, whose familiarity with radiant black zones and their obvious astral connection gave him considerable confidence in his own methods and views. Accordingly he conducted several now forgotten classic experiments which produced Radiometer rotations in ultra high vacua.

BLACK RADIANCE AND THE RADIOMETER

Despite repeated attempts at measuring the so-called "pressure of light" in devices other than the Crookes Radiometer, only one person succeeded in demonstrating a form of light propulsion in very high vacuum. That person was Nikola Tesla, and the feat was accomplished by a collaboration with Sir William Crookes.

Sir William Crookes was especially intrigued with Tesla's work on several counts. Tesla had managed the generation of new light forms. These longer light rays were invisible, penetrating, and decidedly astral. As Sir William was desperately interested in viewing the world of spectres and ghosts directly, he communicated with Tesla directly and privately. The awestruck Tesla reverently responded, finding himself a mentor and friend for life.

Within the white fire which the new Tesla Impulse Transformers discharged, Crookes could see the black radiance in free air...without a vacuum bulb! Tesla's new electric light rays seemed to offer the most powerful means for illuminating the astral world.

Tesla called attention to the Crookes Radiometer on a great number of occasions, seeing a powerful mystery in its operation. In the Royal Lectures and the address to the Institute of Electrical Engineers in London (1892), Tesla hailed Sir William Crookes as the designer of the "most beautiful invention ever created". He hailed the Radiometer as the most exquisite jewel among motors. Tesla frequently gave them to favored acquaintances.

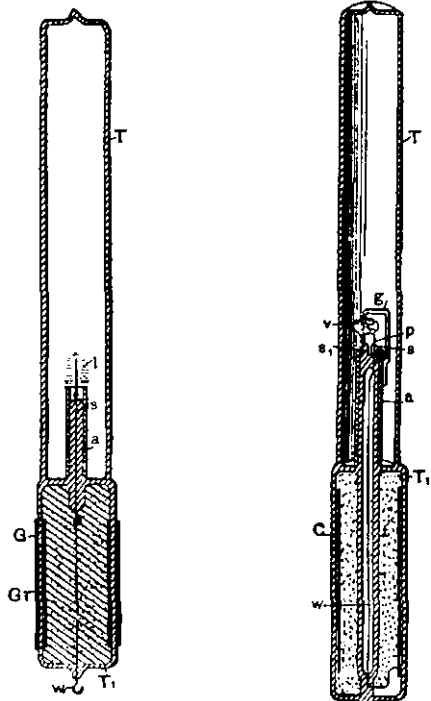

FIG. 34.—TUBE WITH FILAMENT RENDERED INCANDESCENT IN AN ELECTROSTATIC FIELD.

FIG. 35.—CROOKES' EXPERIMENT IN ELECTROSTATIC FIELD.

Tesla first openly exposed the whole thesis concerning the unity of electric rays and light during his Royal Society Lectures. Toward the very end of his presentation, a climax toward which he methodically and progressively moved, Tesla openly disclosed the nature of his new technology. It was the last time he would so openly speak of this technology. The climax marked his departure from polyphase or alternating current research forever, his lecture having been a comparison between weak high frequency alternating radiant effects and strong electric ray impulse effects.

Tesla's preoccupation with impulse currents would dominate all of his future technology. No researcher but Crookes would ever glimpse this truth. Familiar only with Tesla's high frequency alternations, others like Sir Oliver Lodge would equate Tesla with high frequency alternations and forever damn themselves and Tesla to constant misunderstanding.

We are fortunate recipients of this lesson, where both Tesla and Sir William constructed several Radiometers which were to be wirelessly activated by impulsive electrostatic rays.

Whereas Sir William could not obtain movements in high vacua by visible light pressures, the rapid rotation of Radiometer blades in high vacuum had been achieved by Crookes only when using Tesla's electric-impulse apparatus.

Tesla provided the long light rays applied to the special Radiometer which Sir William designed. Electric rays which Tesla described in several patents as being "identical with or resembling those of ordinary light" (patent 685.956, page 3:70) were applied to this Radiometer, both through direct connection and by wireless

beams. Their effect was the instant rotation of the rotor to excessively high speeds.

The simple diagram (fig. 34 & 35) of this special straight high vacuum Crookes Electro-Radiometer is from Tesla's, *High Frequency and High Potential Currents*.

The actual classic demonstration having been performed by Sir William Crookes on the previous day, Tesla repeated the experiment on behalf of his audience. Tesla describes the efficiency of these minute models by adding that "when the glass tube is held anywhere in the (radiant) electrostatic field, the platinum wire becomes incandescent, and the mica vanes are rotated very fast".

In these very successful demonstrations, Tesla was prefiguring the role of electric rays and wireless broadcast power along a proposed future industrial application. Electrostatic motors would convert wireless ray power into motion. Tesla recognized that the Radiometer experiment of Sir William Crookes was indeed a new step in motor technology. Constructed on a larger, more commercial scale, the toy would become a mighty motivator.

Four years later, Sir William published an intriguing article on his special Electric Radiometers in *The Electrical Experimenter* (11 March 1896, page 258). His continuing article "On Radiant Matter" (part IV) describes the strange vane-motivating effects of his own discovered dark space. When flooding the entire Radiometer space, this "black radiance" caused very rapid vane-rotations. Thready black trails could be discerned within this black radiant space, a signature of more recent research (Vassilatos). In this, we, along with Sir William Crookes, again glimpse the black radiance of Vril in action.

DETECTORS AND MOTORS

In their wireless applications, notable observers saw very clearly that Tesla's electric rays traversed long beam distances without the normal losses due to force division. Tesla cited facts which he experimentally ascertained, pointing to a new force discovery which few of the Royal Society except Sir William Crookes could accept.

Tesla plainly stated that a new form of light had been discovered, a light whose rays were longitudinal and capable of penetrating most materials with ease. He went on to say that visible light was merely a shortened form of these new rays, and that they were not transverse in nature at all. Electric rays are described in his patent 685,956, selenium crystals being used to respond to their penetrating power. Only these potent rays of "dark light", as Tesla elsewhere calls them, were ever successful in wirelessly moving Crookes Radiometer vanes in high vacuum. All of the subsequent experiments performed by Sir William employed various constant high voltage sources, being line-conduction arrangements.

RAY DETECTORS

Experimenters very quickly found that Crookes Radiometers could be used as detectors of radioactivity, the vanes rotating with great speed when approached by certain uranium-rich mineral specimens. Others found that Radiometers spun when certain radiant emanations (X-rays, radiowaves, and electrostatic rays) were focussed near the globes. Radiometers measured and compared the intensities of various radiant and radioactive sources long before the Geiger ray-counter was ever developed, giving sight to

otherwise invisible energies.

In later years, Tesla would report the development of a "cosmic ray motor". When asked of its form and function, the aged Tesla remarked that it resembled the Crookes Radiometer, but with certain new modifications. Possibly coated with different radioactive minerals, the vanes of his "cosmic ray motor" would "turn night and day forever". One can imagine the huge size of the Radiometer which Tesla would require in such an application, an undertaking which has not (to my knowledge) ever been attempted by any experimenter.

EXPERIMENTAL ANOMALIES

While the Tesla cosmic ray motor remains for our more aggressive experimenters to explore, certain very anomalous observations have been made with Radiometers of the ordinary variety. We are of course most intrigued and completely preoccupied with the so-called "Vril" effects, those which Sir William Crookes illustrated in his experiments with the "black radiance."

The Radiometer spins vigorously on certain cold cloudy days. This mysterious and anomalous rotation is exceeded in magnitude only by the full force of direct summer sunlight, where other effects come into play.

In addition, placing a lamp at the center pivot point (facing down) should not effect any differential light absorption on the vanes. In this poise, vane surfaces being parallel to light beams, there are theoretically no photons moving or vibrating in lateral dispositions. No local heating effects of the enclosed gas near vanes can be called in explanation of the very rapid spinning which is observed. How then does the device spin with such great force?

Could there be some other energetic medium which, summoned by light irritations, is actually stimulated into propelling the vanes? The mere heat of cupped hands in a darkened room can turn Radiometer vanes with remarkable speed. More mysteriously, the Radiometer can be activated by human auric projections. Under specific conditions, one can effect movements in the vanes by a pointed finger alone (Vassilatov). Other auric movements require the use of hand-held carbon rods. These movements follow very specific physiological sensations, the causative forces neither being infrared rays nor electrostatic fields.

Dr. Wilhelm Reich stated that energetic forms are irritants which, stimulating organismic energy, may cause very powerful motor effects in properly made responsive devices. Dr. Reich used a Radiometer-like device to illustrate this principle.

If visible light alone is not completely responsible for the rotation of Radiometer vanes, then we must look to that Vril foundation for answers.

Radiometers remain the most misunderstood devices in the laboratory arsenal. Their fascinations are endless, the experiments equally innumerable. With these simple and wonderful globes, Sir William Crookes vindicated his own view of the astral world. In his experimental series with electrified high vacuum Radiometers, he opened a new door of inquiry which should have spawned numerous proteges. Though few of the younger researchers gave his great work any regard, the twinkle in his eye showed that he knew the secret. Perhaps one of you will discover some new revelation with one of these! ■

NEWSPEAK

AMERICA'S MOST OUTRAGEOUS BOOKSTORE

CONSPIRACY WEIRDNESS

Inquire Within

1993 D.B. VELVET/A

Now doing Mail Order all over the World!
Send \$4 (US), \$5 (Canada), \$6 (Other) for Catalog
5 Steeple St. Providence, RI 02903 (401) 331-3540

Yes...

Your Ad Should be here!

**Call or Write
for Display Rates:**

BORDERLANDS

**P. O. Box 220
Bayside, CA 95524**

Phone: (707) 825-7733 or FAX: (707) 825-7779

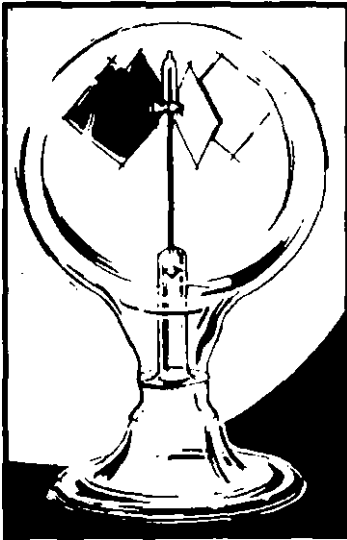

SIR WILLIAM CROOKES'

Radiometer

New!

Referred to by Dr. Nikola Tesla as "the most beautiful invention ever made", the RADIOMETER is an endless fascination. Sir William Crookes, inventor of high vacuum cathode ray globes, created this marvelous motor in order to prove that light pressure could move matter. Called "light mills" by our Victorian elders, the greatest surprise came when the double coated vanes moved in the opposite direction! The RADIOMETER spins on cold, dark cloudy days almost as well as it does in full sunlight! Make your own new discoveries with the "jewel of motors".

Radiometer, #E0028 ... Only \$8.95

The Original Cameron Aurameter

Dowsing Instrument

The Cameron Aurameter, is considered the "world's most sensitive dowsing instrument". It was developed over a 22 year period by the late dowsing Master, Verne L. Cameron. With it, you can outline the human aura, or locate underground water sources. Used with patience and without prejudice, this instrument will give you amazing results. With practice, it will help to open up wonderful and unknown natural laws and forces to you.

Chrome-plated Aurameter, #E0005, ... \$69.00

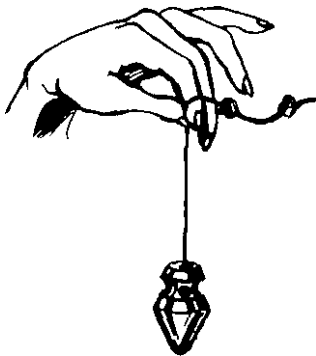

Pendulum

Pendulums! Mysterious aura motor action. Pendulums vibrate or rotate when held in the hand over different materials, and they can be used with radionic instruments, maps for dowsing, and even analysis of food! Skeptics say that minute muscle reflexes cause the motion, but the string on the pendulum may be blocked with solid objects and yet continue to bob! The true scientific use of the pendulum is not to be confused with mediumism or the subconscious mind at all. This is a handy brass pendulum anyone can use to experience the exciting world of dowsing! Machined from solid non-magnetic brass with 4" brass chain. **Brass pendulum, #E0009, ... \$6.00**

Aqualithia

New!

Aqualithia is a natural mineral water. It is a diamagnetic, negatively charged, high grade tellurian water. Recently, more & more articles are appearing that mention colloidal chemistry. Aqualithia qualifies as a very special high energy colloidal or catalyst altered type water with the additional blessing that it is made by Mother Nature — naturally! Original Aqualithia is once again available for research from Borderland Sciences. One half oz. of Aqualithia can be reconstituted into 240 gallons at a cost of less than 10 cents per gallon, making the least expensive of available catalyst waters. **Aqualithia, #E0012, ½ oz. bottle, ... \$25.00**

CS-300 Colloidal Silver Machine

Make your own colloidal silver with this amazing new device.

New!

Why pay \$10 an ounce for Colloidal Silver? Now you can make your own Colloidal Silver at home for a few pennies an ounce! All you need is the CS-300 and your own pure water. Comes complete with two silver electrodes and a 16 page instruction booklet that tells you everything you need to know to start making Colloidal Silver at home.

CS-300 Colloidal Silver Machine, #E0029, ... Only \$99.95

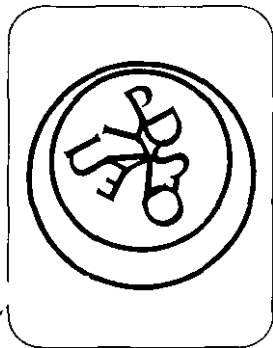
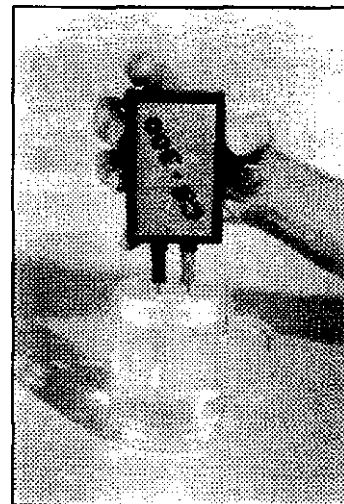

Barcode Neutralizing Stickers **New!**

Studies show that when the symbol at left is placed either on top of or behind a barcode, the toxic effects of the barcode are eliminated. This set of peel-off stickers (featured in BORDERLANDS, 2nd qtr., 1995), are for those interested in ridding their environment of barcode toxicity. Now, when you bring new food items into the house, you can cover the barcode with this sticker. It not only prevents future activations of the barcode, but it neutralizes the toxic radionic imprint that has penetrated the packaging. The creation of these pre-printed, peel-off stickers has made eliminating barcode toxicity in our lives a simple procedure. A set of 100 stickers, that includes 3 different sizes, is now available from BSRF.

Barcode Neutralizing Stickers, 100 (3 sizes), #E0024, ... \$9.95

Ba-gua Mirror

Feng shui — wind and water, *the art of adapting the residence of the living to harmonize with the cosmic breath* — this ancient Chinese art possessed various objects to remedy geomantic defects. The *Ba-gua*, or Feng shui mirror is one of these objects which can be used to deflect *sha qi*, or "breath of ill fortune". Placed over your front door, or inside the home at strategic locations, the Ba-gua will redirect negative energies away from living areas. The Ba-gua is constructed from wood with a small circular mirror in the center and is painted green and red with gold trigrams. **Ba-gua Mirror, #E0031, ... \$6.95**

New!

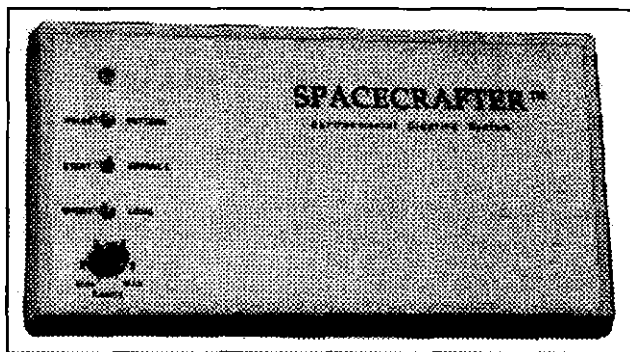
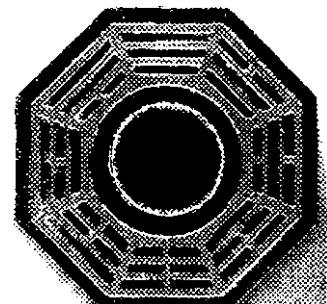

The SpaceCrafter™

Environmental Clearing System

You've heard all about the problems of Geopathic Zones, Ley lines, Electro-magnetic pollution and the biological effects of low level radiation. Now, meet the solution. In independent tests in both Germany and America, the SpaceCrafter successfully cleared the biological effects of all Geopathic disturbances. It also cleared the biological effects of exposure to electromagnetic fields, electrostatic fields and all forms of radiation. It can clear the "oranur effect" that poisons orgone accumulators and unmask hidden factors that perplex radionics practitioners. Battery operated and fully self contained, the SpaceCrafter comes with a Life Time Warranty against defects and a 60 day money back guarantee. **The SpaceCrafter™ #E0017 ... \$499.95**



MIND, FIRE, JOURNEY

AND THERMODYNAMICS

by Marion L. Daye

THE discovery of fire has been repeatedly applauded as the single greatest civilizing catalyst, chief among the consciousness expansive agents of humanity. Though such superficial examinations are found in almost every anthropological science fiction, the true negative significance of fire and its discovery has rarely been addressed. The legacy of fire and its damaging effect on individual world perception must be engaged before the possibility of realistic new technology can ever be approached.

Less the archaic benefactor of society, and more the cunning conqueror, changes wrought by fire became permanent features of the human conscious repertoire. Deeply permeating effects were introduced to the dream-well of consciousness through the discovery and implementation of fire, effects which were both violent and damaging to the basic nature of our being.

Before fire, conscious experience was entirely flooded with water symbols: gushing rain, sweet showers, rushing streams, babbling falls, bubbling springs, forested lakes. The ancient terms describing stellar space was always related to water. If Nature was said to melt, it was melting from blue white ice to trickling water, while generating the watery green life of springtime. But the "watery conscious" experience evaporated away when the crackling red flame was found.

The external, material vision of fire was one having no prior equal. From the moment in which those isolated adventurers grasped the famed "flaming branch" and ran back to their respective tribes, a series of new and permanent awarenesses flickered into the mind of humanity. For those who facilitated the dramatic retrieval there were only honors. Those who witnessed these events were the enthralled co-discoverers. The entire cluster of humanity was part of the focussing effect which fire wrought. Fire was the fascinator.

The early novelty of fire was not applauded by the elders, who saw in fire an enemy. Ignoring their wisdom, younger leaders claved to the fire. The first steps of the fire learning process seemed to be only mind-elevating ones. Fire gripped and thrilled the senses of those who could not cease looking into and through its flames. All

other activities stopped before the fire. The discovery of fire placed a sudden halt on the daily ritual activities. The discovery of fire was like a religious event out of context, one in which a natural force had seemingly summoned one cluster of "special people" together. Societies which discovered and trapped fire believed themselves alone in the event.

Typical of the total surrender which it commanded, each awestruck archaic population imagined that fire was a secret which they alone possessed. That quick and easy first surrender would soon become devotion and allegiance. Gazing into the magick[?] effluence, fire seemed a supernatural agency. Fire evidence, innumerable strange aspects which had only been seen among the celestial lights. Fire was a visitor from the sun then, the obvious first of its wonders was the continuous and seemingly independent production of light. The light of fire was different and separate from sunlight or moonlight. Fire light seemed to be a special and "independent" light. Firelight seemed to be an autonomous, self-generating entity whose radiance was eternal. Fire seemed to be in everything they saw now.

Terrestrial manifestations were projected into celestial realities. Now, everything in the skies were made of fire too. Lightning was fire. The sun was fire. The stars were fires. Only the moon was a cold man crying. Why was he crying? He had no fire. Fascinated only with the radiance which they saw, firelight seemingly "went on and on". It was the same with the heat produced by fire. Those who beheld fire imagined themselves in possession of the "sun body".

Fire was viewed as a mediator between humans and Natural Power. Fire was believed to be a token, a manifestation of favor. When these properties of fire were discovered, humanity lingered in a promised-filled dawn of wonders.

FIRE IS ALL

The initial fascination with fire phenomena, for a time prevented humanity from realizing its negative aspects. At first, fire seemed a wonderful gift. A blessing, an agent of good, a gift from the sun. Fire was magick. It was the power which coursed through the sky, and they alone possessed it!

Fire fascinated and captivated. Nothing could be seen except the flames and the power the flames gave. Social rank began to emerge and solidify. There were those who were privileged to stand nearest the fire. Others fed the fire, tending its delicate and deadly body. Others were banished from the fire.

All cherished the flame. Children gathered the best branches from the forest, delivering them as offerings to the fire. Younger rulers owned it. Specified persons carried it. Elders watched and learned as the watery green offerings of sprigs and saplings were rejected. The rejection of green by red fire was a symbol which humanity especially internalized during these early parts of their experience with fire. It said that fire rejected the old ways, the old images, the old song-myths, the green watery ways. Only dry, dead branches were to be delivered. Dead branches to the transparent, impassive flames of red.

As great fires were made, new discoveries were made by accident. Plants withered in the fire-heated pots, giving up their green blood. Forests now fed families and cured the infirm. The secrets of plants were tortured into the pot by fire. Stones, used to surround the fire, trickled liquids under the magick flames. In the morning, shiny attended trails were and flowing out. In time, these were sharpened and wielded. Tin blades were like razors. Fire the invincible! Fire consciousness gave humanity a false sense of world pre-eminence. With the new found ally of fire, humanity assumed a dominant world poise over Nature.

Torches, children of the fire, were carried up into the deep caves. The once frightened rulers now bravely ventured into the mouths of the mountains, bearing fire before them into caverns where bears once ruled. There, plant blood was splattered over hands and feet, marking the innumerable secret places which archaeologists now thrill to find. Deep in cavern recesses, the song-myths were enacted. Against the flickering red, where shadows of "the tellers" went up and down, children learned the story of the world.

A change had come. The young rulers were pleased. Some remembered the fearful time before fire. They told that the world was a great darkness, a haunt for frightful creatures. Before the coming of fire, there were monsters in the dark. No one remembered the water songs any longer. A few elders knew the secret which would restore the former time, the watery songs of lush green

and blossoming life. But the young tribal rulers would kill them if it were now told that water could destroy fire. They knew it, but kept the secret deeply hidden. Fire was "invincible"!

FIRE FOCUS

Fire completely captivated each young mind, each body, and each tribal group which discovered it. The first and most fundamental fire-provoked change occurred in the mind of humanity. Streaming forth as a new and powerful sense stimulator, fire fascinated human attentions out into the external. Fire coaxed consciousness away from its true and central inner focus. The change was subtle, but definite.

With the image of fire came a comparison of externals and internals. What fire made was solid. Food, tin, copper, spearheads, blades, pots. What dreams made, vanished. Songs. Pictures. Talk.

Therefore fire was thought "true and real" while consciousness, the very wellsprings of being, was considered "the lie".

The once continuous flow of imagery between Nature and individuals was now interrupted, replaced with transparent streams of fire lacking image and content. Fire was a vacuous fascination. There were no images, no feelings, no memories, and no message in the flame. Fire was the one item in Nature which had no soul, and could give no life. Fire took life. Fire was the antithesis of life, and humanity desired it for what it promised. Survival. Protection from fierce beasts, light in the



darkness, and warmth against the deadening cold of winter. For this, humanity innocently traded its inner fortune.

Having no previous associations or images other than itself, fire captivated and permeated the minds of those who beheld its brilliant dance. Individuals who were once in total fusion with the radiance of their innermost thought life were now externally captivated by the dancing display of lights. Individual attention was completely externalized on the central fire, challenging the eternal underground streams of consciousness. This is the period of fire-learning during which a strange and damaging transmutation of consciousness occurred.

INVASIVE FIRE

The generations cold treasury of dreams, symbols, images, associations, and themes were now invaded by the fire god.

Conscious associations were once freely shared, a wash of imagery and meanings flowing between individuals and every aspect of the Natural environment. The water myths. This formed the conscious integrity of individuals with their world. Nature suffused individual consciousness with its own animistic supra-vitality, the mindstate very evidently undamaged in young children.

Until the advent of fire, the otherwise freely expressed mind projections, the dream symbols and dream images, once successfully propelled humanity toward natural and empirical discovery. The old world was the watery time, the time of water songs. Fire sent its red tongues, like so many invasive rootlets, deep into the wells of human consciousness. Its ruthless seizure and incorporation of every symbol, imagination, and theme destroyed the old watery world view and its experience.

Fire destroyed the old world, piercing, appropriating, and re-associating all the song-myths of water. When fire was found, it alone focussed all attention. All consciousness focussed on fire. The result was an imageless, restructured consciousness in which fire itself played the unifying role. Fire, the very image of self. This fire-fused amalgamation no longer permitted the oceanic consciousness which society once freely enjoyed. Now consciousness was focussed into a constricted singularity which excluded the one who experienced it. Fire had nothing to offer the soul, nothing with which to fill the inner heart. It glimmered, a being unto itself "out there". No feelings, no pictures, no stories, no songs.

Having thus literally threaded through the store of images and symbols, opportunistic fire threshed its hurtful path through the thesaurus of mind, ripping the conscious stratum wherever it went. Societies which possessed fire developed new and unnatural mythologies. Fire myths. The external interwoven connectivity of mind and Nature, the extensive vine-work of conscious experience, was totally damaged. Rent asunder from within and reconnected in fiery streams.

All naturally derived experience, thought, imagination, and myth was now smelted into the fire theme. The invasion had new and unexpected consequences, every component of consciousness being thrown out into the fiery focus. The first curse of fire was its invasion of consciousness and its enslavement of conscious process, a fusion which has permeated every mind to this very day.

What did fire do to our minds? Fire blocked us from realizing, with the inner urges which drive our being, the whole of natural

provision and the plethora of survival-available energies. Fire took humanity out of the cavern of mind, the safe inner place from which all symbols, images, and other survival urges flow. This dangerous and vulnerable poise intensified our outer dependency on fire while separating, alienating us from our true ground. Contact with our true selves was lost.

CAPTIVATOR

Not only because of its captivating presence, but because of the power it gave, all minds were pulled into the fire. The water myths represent a whole way of being, not just a cycle of imaginations. In the ancient water songs and water myths are found the very wellsprings of consciousness, the experiential mindstate in which all things natural blend with all things imaginal.

These song myths did not envision the death of light. Water

myths see the sun reborn each dawn, nothing required of humanity. After rain, after dew, after the night, water comes. The sun comes, all flows together and solidifies. The dreams flow at night, the sun going down. All flows in the waters of forever. The dreams, the visions, the knowledge, the past, the future. All flows like waters flowing. The dreams crystallizing in the morning. Found in the forest are the dreams and the dream gems, sparkling. In the water songs, light is eternal. Endless light. Fire placed a halt on these old dreams, on their symbols, on their flowing images. Watery inner imagery ceased, and fire



flickered on.

The focus now outside. The old stories of the world and its creation from the water were heard no longer. Fire divided the mind of society, driving attentions away from the true and radiant conscious source. Out of the mind cavern. Fire de-focussed consciousness and its images of wonder, pulling all attention to itself. It was cruel and demanding. What was the first fuel which the fire demanded and received? It was the whole former world and its song-myths, plucked, burned from the minds of those who yielded to the flames.

FIREWALL

All other symbols and potentials were drawn into the flames, serving them alone. Crafts, taken to the flames, became transformed in nature and intent. Metallurgy, defense, medicine, art.

such were the fire drawn crafts. Fire focussed all attentions outside. Fire demanded attention into itself alone. To serve the flame meant to survive. Fire became synonymous with survival. Humanity was now always only a flicker away from the close-wandering predators.

Fire was the wall. Predators without, humans within. Fire was a cage, an entrapment. Fire produced a mindstate which eventually projected outward to become generalized as an apparent worldstate.

Fire provoked a defined schism in perception and thought process. The consequences to this schism, this alienation from the inner world, was devastating. Fire and society were bound together in an unhealthy, unnecessary union which successfully masked humanity's deepest visions.

Humanity was now alienated from the life of its own conscious expressions by a technological agency whose presence has remained. Fire lent a false independence from Nature's provisions.

Imagining themselves independent of natural dictates. Humanity now believed that Nature was a subordinate entity. Humanity was alienated from Nature's dreams and dream-symbols. Fire burned human consciousness, teaching it a lie. The inflation of self, derived from savage use of fire craft, produced a defined schism between humans and the natural world upon which they truly relied.

With fire craft came a new outrage. The "torture of Nature by deliberate human intent. Those who used fire no longer perceived themselves as passive recipients of natural benefits. They now took whatever provisions they demanded by force.

Nature recoiled from the high wielded torch. Plants and animals alike, whole forests and herds all instinctively withdrew and perished by the flame. This second curse of fire successfully alienated humanity from Nature. At war with the Nature which freely and fluidly gave her bounty, humanity wielded frail fire as a hard weapon. Because of the projective will by which Nature could be "subdued", many societies lost the continuity between their own dream projections and Nature.

All aspects of life were gauged against fire. Fire became the social reference, the ultimate expression of dominion. New song-myths even dared to tell that Nature was really "fire born". Fire focussed humanity on fire. Nature was seen through fire. The fire of Nature was sought.

Wherever naturally found, fire was worshipped. Fire was strong. Water was weak. Fire burned water. Fire repelled water. All of

Nature was seen through the flames.

Mountains seemed to be frozen flames of red and violet, the green trees resembling "green flames".

FIRE SLAVES

The absolute survival need for fire was revealed as an insidious new dependence. Fire began enunciating laws to its willing servants. Empirically learned, these demands were simple equations. No fuel, no fire. No fire, no survival. No fuel...no survival. The simple idea came with a swift and terrifying finality. The third fire curse was the enslavement of human action to demands made by flame, determinations which had now become absolute survival necessities. Should the fire vanish, survival would be totally imperiled.

Humanity learned, and never forgot the lesson. This fear

travelled deep into the mind. Humanity has been branded by its mark. The lesson equates the death of fire in the absence of labor. Work makes light. Work makes warmth. Work makes good. All good comes from work. Work makes life. Work makes survival. It equates survival with fire, fire with labor, and light with death. Remarkably modern. The theme re-emerges in the arts periodically.

FIRE PRIDE

Fearful humanity entered into league with the demands which fire enunciated, serving those demands. Now unable to envision an alternative power equal-

ling fire, survival was determined exclusively by one obsession: the acquisition of fuel. Tribal addiction to fire. Fire taught humanity that there were only two realities on which humanity's survival would forever depend: fire and fuel. Servitude to fire taught humans that they were the secondary beings. Fire alone was the supreme Natural expression, the apex by which light was gained against the night, and heat was gained against the death of winter.

The loss of fire was now the greatly feared event. Fear of the cold. Fear of the dark. Fear of what lay waiting in the dark. The pride of fire led humanity out into frozen wastelands where, formerly in times of the water myths, none would dare venture. Torches high, the adventurers led their tribes onward, ever onward. Elders died in the snows, watching their bodies melting the ice. The water songs sung as they died. The women complained, and children shrieked in the cold. The pride of fire forced



the tribal leader to drive them all northward to new lands.

Not heeding the cry of their needy, cries from the sea of consciousness, the proud forged onward. Fire would keep them. Fire would protect them. Fire would drive the ice back. Now amid the icy steppes and glaciers, humanity found itself in a new nakedness. Vulnerability by seduction. Fire had led them forth into dependency zones, where their lives were in new and unfamiliar perils. Too late to recall sense and reason, many tribes were destroyed by fire's ploy.

In northern mountains of blue ice there was no fuel. Many tribes became extinct when fire was lost. Did they stoop to burn each other for the fire? Frozen bodies seated on stone terraces in circles, thick brown hair blowing in the frigid wind. Lost fire. Lost life. All of northland survival was now desperately focussed on fire. Fire, the once wonderful token, began unmasking its true personality. Fire taught humanity that, in the absence of its presence, there would be no survival. Fire was audacious, existing at the expense of human life. Fire supplied certain needs while threatening the lives of those who cared for it. Its chief threat was extinction. If the fire went out, humanity would extinguish.

FIRE EATER

Fire light and fire warmth were both identified with labor, loss, and impermanence; three deadly killers of the human soul. The death of light in the absence of fuel translates directly to the mind in the death of hope. It was a lie which could have been first undone by simply looking into the sun, or gazing at the stars. The old water songs. Humanity's fire promise of freedom and survival became gross enslavement. Fire was more like a beast than magick now.

Fire devoured food of its own. And when devoured, fire vanished with its quarry. Fire would require the whole world for its food, the very ones who tended the flame being consumed. Fire would soon devour everything if so allowed. It was only in this place of betrayals that the transparency of fire was thoroughly understood. Fire was a betrayer of humanity. Fire was the malicious and cunning one. New fire songs became fearful, telling of the fiery fate awaiting the world. Ultimately all of Nature would be drawn into the flame as its food. Fire would eat the world. Fire hissed in red...a dragon waiting to be fed. Fire suddenly became a hideous and malicious being of evil intent in song-myths.

Worse than the predators which roamed at night, those from

which fire gave immunity. Fire was the ultimate predator, king of the man eaters, and he had brought into the camp with honors! Now historically viewed and mythically pictured as a deceiver, fire became a fire bird, a fire breathing dragon, a captivating power from which humanity could not escape. The sting of fire in the all too sensitive heart of humanity left a defined wound. An impression, a lie, a false reality.

And then, fire taught the deadly lie which has singed minds and pursued technologies to this very moment. The single lesson which fire burned into the mind of humanity was one from which all laws of thermodynamics are directly drawn. Fire taught that its light, all light, would come at a price. Fire needs more than labor. Fire needs death. Fire devours the dead branch. Fire devours all branches. When the forest is eaten, fire would devour another.

Fire became the eater of dead things. The devourer of once-living things for the gift of its light. A simple exchange. A deal which humanity struck with its new master. Fire light came from the souls

of trees, from the death of the watery green forest. Light came from the death of Nature. Monstrous fire required a price, a life, before it would give its light. The equation was a simple one. Fire gives light, fuel gives fire, and death gives fuel. This equation of logic defines the permitted bounds of fire's survival, away from which humanity may not stray. In engineering terms, the equation sums the laws of "thermodynamics".

We are yet living in the boundary which fire had set for society. That boundary is a world model which has been rigidly consolidated for several centuries by countless academicians.

The fire lesson so burned itself into the human psyche that it now becomes impossible for them to envision any other than the thermodynamic world model. Today, the hard social demand for machinery is predicated on the survival demand. More light, more heat, more cold, more motion, more food, more media. Fire taught humanity that fixed natural rules would limited their every escape from its dominion.

FIRE MASK

Fire was the technological first wonder, and the first technological failure. Fire produced a paradigm of loss, of consumptions, of exchanges, of conversions, of thermodynamic boundaries. The archaic disappointment produced a distorted view of Nature, and a warped quantitative science. There is no escape today for th



whose insistence on the fire paradigm has bound their vision into its cruel service. Fire defined the engineering concepts of the "impossible".

Fire blocked contact with the inner water world. Fire placed a mask, a template over the mind of humanity. To this day, consciousness is likened to a "crucible" where life's fire brings our thoughts to "fusion". Thermodynamic concepts, proceeding from the historical use of fire, have so rooted themselves in human thought structure that all energy forms are comprehended in terms of heat. Energy, all energies, are always each referenced against their "heat equivalent". Thermodynamic laws actually represent the archaic template through which all energies, all technologies are referenced against...fire.

Thermodynamic law is the obvious artifact of fire, the template of which we speak. It totally binds our vision, fixating our minds. We see no other way. We see nothing else. It is a world of entropy, of lost fire. Ever losing the fire. The fear dominates. Fire masked the mind. The thrumming machine algorithm is the yet persistent desire for fire, a desire based on a false premise early learned by those who first used fire craft. The undying demand for new machinery is framed in a lie which promises new survival, but which is only a cunning instantaneous demand for fuel. If there is no fuel, then there is no heat flow. No heat flow means no motion. No motion means no machinery. No machinery means no survival. If there is no fire, there is no society. The lie persists, the boundaries policed by academicians and made secure by financiers. It claims that without heat flow, without fire, there is neither machinery nor human survival.

Fire craft, as the unfortunate first technology, produced negative templates in human consciousness which forever biased human technological expectations. Present technology embraces the fatal thermodynamic theme, embodying the "boundary" which fire craft taught humanity. It is the expected limit in which a machine, exchanging an energetic flow, will perform. In actuality, the thermodynamic boundary is that perimeter which fire has jealously set for humanity, binding attentions so close to its side that we have forgotten the whole of Nature and its thesaurus of energetic wonders.

We design machines exclusively with the fiery "working substance" in mind. If a machine has no working substance, it cannot work. This explains the sharp separations existing between

works of art and works of technology. Art, in the archaic world, functioned in the watery world. Visions moved through and around artworks. Art worked. Now, if the art does not move, get hot, ring or light, it "does not work". It is not machine. It is art. Now it is said that artwork is no work at all. Art is fancy. Machine is real. The fire lie again.

WATER SONGS

The harsh lessons which fire craft brought archaic humanity might never have found so secure a place in the human psyche had the more fundamental energy been technologically explored and socially developed. What fire did to humanity profoundly distorted and divided the human perception of Nature, forever fixating both our world view and rigidifying technology within the so called "thermodynamic limitations".

Grave damage has been done to consciousness, permanently filtering our vision and thought life. The damage has poisoned our technological dreams. Our desperate need for more heat, more light, more motion, is incapable of discovering any other means for attaining those manifestations without fire. Machineworks without fire are deemed "impossible". Few engineers consider the possibility that there may exist more fundamental natural energies than fire or heat. Those energies run eternally. Those energies are everywhere, not the conventional natural manifestations of sea and sun, stars and wind alone. There are other energies as there are visions and dreams. In all our thoughts concerning survival,



we have not been willing or able to escape the fire paradigm.

Despite this sad mindstate from which many have not escaped, the horrid vision-binding template of firecraft does not represent a complete world view. Fire is not the only energy which Nature has to show us. It is time again to consider what the watery song-myths of the old green forest world yet sing. There is fire, and it kills. But Nature is a garden, a thesaurus of dynamics.

The working substance of the water world fundamentally is visions, symbols, archetypes. And there are technologies by which these visionary streams are summoned and magnified. But, these visionary currents do find their materializations in the natural world. Children know this. Empirical inventors seek those materializations. And those materializations, ever present and scarcely seen, are periodically and "accidentally" discovered.

It is only when the visionary currents so suffuse individuals that the fire mask, the template, is lifted for a rare instant. It is then that "anomalous discoveries" are made. In truth the "anomaly" is our own mind block. The lifting of that template requires enormous watery suffusions of dream and faith in the minds of those who seek.

This is why those who discover "anomalous" energies and who build "anomalous" technologies are rarely part of the academic fold, where the fire template is harsh and killing. Where the dreams are shunned, hated, feared, eradicated, and buried. In truth, the watery suffusions of symbol, image, and dream destroy the fire template. The elders knew the secret. Water quenches the fire. Water break fire.

WATER WAY

It is both astonishing and conspicuous that thermodynamics, a development of great minds, had absolutely no regard for the consciousness which spawned its mathematical phrasing. Consciousness should be the very first consideration when studying any science. Consciousness is the energy by which we experience and by which we know our being.

Had discoveries of the naturally prolific energy, preceded the discovery of fire, then the human psyche and its various technological expressions would not have focussed on fire and its "thermodynamic limits". There exist fundamental energies whose nature is to grow from negative states, contrary to theoretical limits. The naturally prolific energy is the energy of dreams. The real materializations of dream currents are those "anomalous" energies, everywhere potential. They are real. They are not ephemeral. They have been found and used by numerous inventors, and they are embodied in patents which work.

Unlike fire, plants do not exist to consume and then vanish. Living things everywhere seen defy the thermodynamic rule. Concerning the growth process and the tendency toward living organization, fire can teach nothing. Survival, machines, fire, and fuel are each links in a heavy chain which has been cast around the neck of humanity far too long.

Fire. Fuel. Fire. Fuel. The ring of captivity from which neither

minds, souls, nor bodies have escaped. The ring tightens, enslaving human vision along its closed loop. It is the very image of the snake, devouring itself and choking humanity to death in the process. Fire split the mind of humanity, fixating all vision out along its winding, smokey paths. No one can even envision another way to obtain energy. It falls to those sensitives and dreamers who are fortunate recipients of accidental observations and rare phenomena to find the way out.

The magick which breaks the circular spell is beyond those who have forgotten how to dream. The images we require have always been speaking to us. They are accessible. They do not require arduous exercise or meditations. The images are forever flowing. They are the deepest radiance. It is we who have forgotten how to recognize them apart from the background of thoughts which occupy us.

Those whom fire has seared cannot and will not accept these ideas, but there exists an energy stratum in which both inner dream and outer Nature are in fusion. The art of observing imagery and deeper meanings is the common experience of those who love rich poetry. It is a sensitive art, requiring a willingness to enter the written script by which poets lead us.

Unlike poetry, life! no pre-written "image script". Nevertheless, our daily activities are replete with spontaneous emergence of images, impressions, and essential meanings. This deep radiance is cherished by those who recognize their manifestations against the background of the ordinary. Distinguished, as it were, among the world-visual spaces which surround us.

WATERY REFLECTIONS

Though energies are both employed and liberated in organic life cycles, the growth of living things is not primarily driven for energetic reasons. Energetic conversions, flow, and exchange may be traced throughout organisms. Nevertheless, we are innately aware that these thermodynamic maps do not in any way represent the primary organismic function or reason for being. One may cite numerous references which indicate that a primary sensitivity and consciousness is shared by vegetation (Bose, Backster, Lawrence). Despite these marvels of discovery, we must look to the labora



of our own experience for deepest understanding.

But, some will argue, consciousness and matter are "completely different" realms! Nevertheless, one will notice that specific imaginal sequences persistently occur in specific locations. They come unbidden, though forgotten for years. It is remarkable how they come, and with their attendant moods and sense. Exact synaesthesis similacra. Conscious energy flows through material forms, being discharged into percipients who wander near them.

Consciousness alone is the energetic flow which discerns, enjoys, and participates in world reality. The fundamental world reality is a sea of consciousness, a watery flood of prolific conscious energy.

Symbols and forms of thing unknown, emerging from the dream sea, once exclusively guided human actions. Inspirations, revelations, and visions spoke as nature spoke, driving the sailed ships of civilization toward the sun. There was no difference, no separation between dream and Nature. Consciousness, conducted through our being as images and meaningful symbols, can never be measured in thermodynamic terms.

The energy of consciousness can never be gauged according to the ridiculous limitations set by the fire paradigm. Consciousness cannot be measured directly. Despite the quantitative inability to measure this most fundamental energy form, consciousness persists.

Dreams and dream symbols are evidence of the natural radiance. Images, symbols, and dreams come, unbidden messengers up from the deepest world. The great minds have each attested that this is their true and only source of creative potential. The numerous mythologies clearly picture the magick of radiance, of

endless light, throughout their lovely rhymes. The old watery green gabled world of mountains and forests. The deepest radiance is one which is first experienced as consciousness itself. The evergreen tree, watery forest symbol of endless life, would have taught humanity everything required without fire.

After centuries of languishing in the fire paradigm, ancient natural philosophers refocused their vision on the fundamental world of dream and mind. There they learned that subjective fusion with both dream and Nature is fundamental world reality. In this ground of being they began making astonishing discoveries. Emergent symbols and images formed wonderfully sinuous paths into the external world. The symbols envisioned, radiant and undying, were sought and found by visionary seekers. The arts, born of these realizations, were called Alchymy and Geomancy.

The world is a garden of conscious symbols which has materialized. Like crystals, half in and half out of their ground fully formed, portions of the dream symbols were found in Nature. Metadimensional visitors, bridges between the worlds, the radiant natural correspondences were located and retold. All the dim shadows of the radiant world.

The desire for the magickal and the wonderful does not die. Desires exist, it has been said, because the objects of desires exist. Though yet unseen, the sweet thorn of an unrequited desire cries out for its fulfillment. Desires are messages to us, illuminated visions of realities which can be touched. Dreams, images, and symbols of eternally radiant lamps, of endless light, represent a world which lives within that world which appears. It is the very soul of the apparent world which projects these symbols. The sensitive few who quest for these realities are never disappointed. ■

ADVENTURES UNLIMITED

Two sensational new books from Adventures Unlimited that will change the way you think about UFOs and ETs!



Man-Made UFOs, 1944-1994 by Renato Vesco and David Hatcher Childress is a comprehensive and in-depth look at the early "flying saucer technology" of Nazi Germany and the genesis of early man-made UFOs. From captured German scientists, escaped renegade battalions of German soldiers, secret communities in South America and Antarctica to today's state-of-the-art "Dreamland" flying machines, *Man-Made UFOs* blows the lid off the government UFO conspiracy. This astounding book is required reading for students of technology suppression, UFOs, anti-gravity, free energy conspiracy, and World War II. Packed with photos and diagrams. 512 pp./trade paper/\$20.00 includes 1st class shipping.

Extraterrestrial Archaeology by David Hatcher Childress presents shocking evidence that many of the planets and moons in our solar system are or have been inhabited. Journey to strange and fascinating worlds in a visual search for ancient structures, surface features and evidence of ETs on the Moon and nearby planets. Large format photos allow you to see for yourself the amazing pyramids, domes, spaceports, obelisks, robot mining vehicles, and other anomalies discussed in this book. Heavily illustrated with photos, diagrams, and maps. 306 pp./trade paper/\$21.00 includes 1st class shipping.

THE source for:
Ancient Wisdom, UFOs,
Lost Cities, Conspiracy,
Anti-Gravity, Exotic Travel,
Atlantis, Tesla Technology,
Free Energy Science, and
much more!

**Man-Made UFOs
1944-1994**
50 Years of Suppression



Renato Vesco &
David Hatcher Childress

ADVENTURES UNLIMITED
303 Main Street • P.O. Box 74
Kempton, Illinois, 60946 USA
Tel.: 815-253-6390
Fax: 815-253-6300

EXTRATERRESTRIAL
ARCHAEOLOGY

Incredible Proof That
We Are Not Alone

David Hatcher Childress

Call, write,
or fax for
our FREE
catalog,
a truly
astonishing
collection of
rare, esoteric
books and
videos.

NEW BOOKS FROM BORDERLANDS



GOETHE'S SCIENTIFIC STUDIES

Edited and translated by Douglas Miller

Goethe's scientific work is less familiar to the reading public than his poetry, yet his understanding of natural phenomena displays the same sensitivity and brilliance as his depictions of human relationships. In his own time his ideas often met with opposition, and it is only today that the full significance of his accomplishments is being reevaluated. Goethe calls upon the scientist to develop his perceptions both inwardly and outwardly in pursuing the continuum of nature through a world which is interconnected and alive. His methodology is thought-provoking; his research in anatomy, botany, physics, chemistry, zoology, meteorology, and geology challenges modern assumptions just as it challenged the tenets of his own time. This volume brings the reader a new translation of over forty carefully chosen selections from Goethe's scientific writings; few of these have been available in English. A major section is devoted to Goethe's great work on optics the *Theory of Color*. The text is accompanied by several of Goethe's original illustrations, and the editor has provided an introduction and explanatory notes to guide the reader through the pleasures and complexities of Goethe's work in the sciences. #B0333, 344pp, paperback, ... \$16.95



THE SCIENCE AND ART OF HEALING

by Ralph Twentyman

Twentyman brings all his medical discipline and experience in homeopathy and his wide study of history and mythology to bear on the bountiful store of remedies in the natural world.

"This is a remarkable book by a most experienced healer. It is a healing experience to read and I hope it will become a classic." — Francis Treuhertz, *The Homeopath*

"It is safe to say that it contains more original thoughts on homeopathy and its place in medicine than any other book published in the last few decades." — G. Douch, *British Journal of Homeopathy*.

#B0324, 320pp, paperback, ... \$27.95



THE RHYTHMIC FORMATIVE FORCES OF MUSIC

by Michael Theroux

In most cases, books on the subject of the mystical properties of music merely discuss it from an acoustic vibrational standpoint. It is from within the borderlands of science, which endeavors to understand the qualitative nature of things, that the subject of music is treated in this work. Leaving behind the innumerable, mechanistic definitions of the "music of the spheres", this book will help you to understand the qualitative aspects of our musical cosmology, and will give you a means of directly applying this new knowledge. Subjects covered include: Cosmic Rhythms, Alchemy, Counterpoint, and Projective Geometry. Counterspatial Geometries and Musical Dissociation, The Tellurics of Music, and more. Included in the book are the rare texts, "Sound in Relation to Health" by Horace Leaf, and "The Eidophone Voice Figures" by Margaret Watts Hughes.

#B0299, 144pp, velo. ... \$11.95

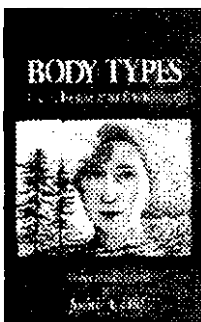

THE ASTROLOGICAL BODY TYPES *Face, Form, and Expression*

by Judith Hill

This is the most complete compendium of Astrological Body Types available anywhere. The book contains over 80 illustrations accurately depicting the archetypal Zodiac Sign Types, Planetary Types, Elemental and Modal Types. Character, appearance, vocational suggestions plus numerous example personalities are included for each astrological body type. Extra highlights: the Lunar Nodes and Physical Appearance, Face-Reading Fundamentals, and Significators of Physical Appearance in the Birth Chart. "This uniquely intelligent milestone goes beyond the realm of physiognomy to also provide a delightful approach to the fundamental principles of astrology itself. Appropriate for advanced professionals and beginners alike." — Barbara Morgan, Director of ISIS: Institute for Stellar Influence Studies. #B0323, 167pp, paperback, ... \$17.95



DESIGN ECOLOGY

by Michael Riversong

An essential compendium of information on several aspects of environmental balancing. It begins with a summary of design principles developed in ancient China known as Feng Shui. These are related to daily life as we know it, with the first explanations ever offered for why some of these "old Chinese tricks" actually work. Section 2 is about our invisible environment, including electromagnetic fields and new information about Geobiology. Section 3 covers common household toxic chemicals in an easily understandable form. Ways to deal with these problems are summarized. Section 4 contains several new solutions to environmental problems, including the current state of Solar Energy, Lighting techniques, and experimental Field Modulation devices.

#B0334, 225pp, paperback, ... \$16.95

NEW BOOKS FROM BORDERLANDS



THE SECRET LIFE OF PLANTS

by Peter Tompkins and Christopher Bird

Although this book focuses on the plantworld, it is possibly the finest introduction to borderland sciences ever written! Exploring the world of plants and its relation to mankind as revealed by the latest discoveries of scientists, *The Secret Life of Plants* includes remarkable information about plants as lie detectors and plants as ecological sentinels; it describes their ability to adapt to human wishes, their response to music, their curative powers, and their ability to communicate with man. Authors Peter Tompkins and Christopher Bird suggest that the most far-reaching revolution of the twentieth century — one that could save or destroy the planet — may come from the bottom of your garden. This book is also a virtual "who's who" in the field of the borderland sciences and details many remarkable and reproduceable experiments. #B0332, 402pp, paperback, ... \$15.00



PLANETARY INFLUENCES UPON PLANTS

by Ernst Michael Kranich

At the beginning of our century a significant change occurred in the investigation of life. The great achievements of the nineteenth century had taken place in the investigation of form; anatomy and comparative morphology had their golden age, of which little is noticeable at universities nowadays. But more recently the interest of biology has shifted from the external form of the organs to life processes and behavior. This book carefully traces the relationship of the "form language" of plants to the planets. Many examples and drawings are included illustrating the connections between the orbital paths of the planets and the shapes and movements found in a variety of plant life. Highly recommended. #B0329, 184pp, paperback, ... \$12.95

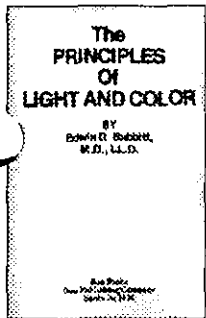

PRINCIPLES OF LIGHT AND COLOR

by Edwin D. Babbitt.

Including Among other Things: The Harmonic Laws of the Universe, The Etherio-Atomic Philosophy of Force, Chromo Chemistry, Chromo Therapeutics, and the General Philosophy of the Fine Forces. A partial list of the extensive contents Includes: Harmonic Laws of the Universe: Light, Nature, Unity, Diversity, Harmony, Harmonic Colors In Architecture, Colors in Dress; Insufficiency of the Present theories of Light and Force: Chemical and Therapeutical Properties of Color, Shadow is an Entity, New Worlds of Light and Color; The Etherio-Atomic Philosophy of Force: Nature of Atomic Spirals, Ethereal Forces, Grades of Ether; Transverse, Converse & Paraverse Layers of Atoms; Positive & Negative Electricity; World Formation; The Sun Forming Process, Spectrum Analysis; Chromo-Therapeutics: The Healing Power of Color, Disastrous Effects of Lack of Sun light, Practical Instruments for Color Healing; Chromo Culture of Vegetable Life; Chromo Philosophy; Higher Grades of lights and Forces: Odic Light, Magnetism; Beauty of the Fine Forces; Finer vision; Vision and the Eye. This is the complete edition of 1878, including all four full color plates and hundreds of illustrations.

#B0064, 576pp, index, color illustrations, paperback, ... \$55.00

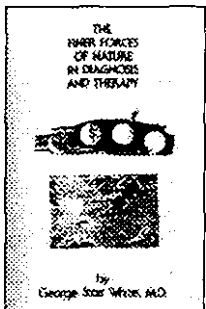

THE FINER FORCES OF NATURE *In Diagnosis & Therapy*

by George Starr White, M.D.. (1929)

Contains Dr. White's early observations and subsequent findings; Polarity Health; Colors; Magnetic Energy; Interference of Energy, Diagnosing All Un-Health; Moonlight Influences All Life; Destructive Forces Explained; The Bio-Dynamo-Chromatic System of Diagnosis; "Harnessing" The Finer Forces of Nature; Colors - Their Use For Treatment As Well As For Diagnosis; Rhythm-Duo-Color Therapy; #B0335, 231pp, paperback, ... \$17.95



ANGELS DON'T PLAY THIS HAARP *Advances in Tesla Technology*

by Dr. Nick Begich and Jeane Manning

The U.S. government has a new ground-based "Star Wars" weapon which is being tested in the remote bush country of Alaska. This new system manipulates the environment in a way which can: disrupt human mental processes, jam all global communications systems, change weather patterns over large areas, interfere with wildlife migration patterns, negatively affect your health, and unnaturally impact the earth's upper atmosphere. The U.S. military calls its zapper HAARP (High-frequency Active Auroral Research Program). But this skybuster is not about the Northern Lights. The device will turn on lights never intended to be artificially manipulated. Their first target is the electrojet -- a river of electricity that flows thousands of miles through the sky and down into the polar icecap. The electrojet will become a vibrating artificial antenna for sending electromagnetic radiation raining down on the earth. The U.S. military can then "x-ray" the earth and talk to submarines. But there's much more they can do with HAARP. This book reveals surprises from secret meetings. PROJECT CENSORED — a prestigious panel of journalists — judged HAARP to be in the top ten under-reported news stories of 1994. #B0322, 233pp, paperback, ... \$14.95

Reviews

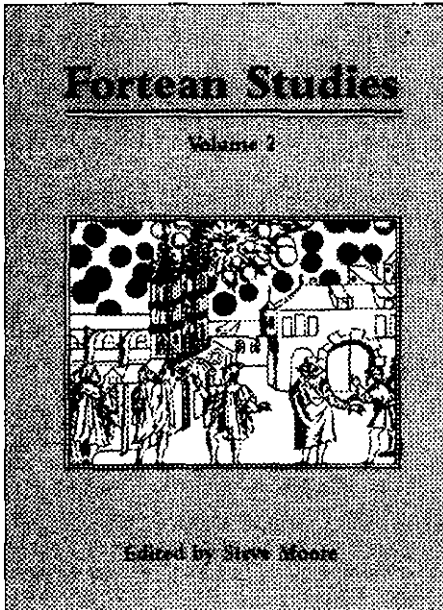
**Fortean Studies Volume 2**

Edited by Steve Moore

Fortean Times, 20 Paul Street, Frome,
Somerset BA11 1DX, UK
ISBN#1-870870-700

Fortean Times is a British journal becoming increasingly popular in the USA and other parts of the world. It has a lively style, and ably covers all the strange bits of flotsam and jetsam which don't fit into standard science, continuing the great tradition of Charles Fort. Now, the journal is printing books, which allow a greater in-depth view of these topics than a magazine format can offer.

Twelve sections of the book present a good overview of items which should prove of interest to anyone who is interested in things we're not "supposed" to be interested in. The thirteenth section is an index of Fortean Times for 1993.

Although the magazine is written in a lively style which borders on the sensational, that is not the style of the book. Here, the evaluations are consistently reserved

and reasonable, couched in every relevant fact which can be applied to the topic at hand. This works well, enhancing the credibility of the book.

Topics explored include a thorough examination of rains of frogs and fishes around the world, mystery cats, ocean lightwheels, and the legendary UFO land of Magonia.

An essay about pseudo-archaeology which contributed to Nazi propaganda promoting the idea of the Germanic super-race is especially poignant. It shows how easy it is for science to be perverted, leaving up to our imaginations how similar devices must be working today in some areas. Hopefully this will contribute to the vigilance we must maintain against anyone who could destroy large numbers of people in an insane political or religious quest.

Another section explores the evolution of odd rumors. The case in point is a belief which arose early during World War I that Russian troops were being quartered in Britain in large numbers. This is especially entertaining in light of a rumor current in some circles in the United States that Wyoming and Montana are hosting thousands of either Russian or United Nations troops ready to invade the rest of America from within. Residents of Wyoming (this reviewer among them) are especially amused by these rumors — we would certainly know if something were up. The sheer logistics of transporting these troops into our area for quartering, and then back out for an actual invasion, are mind-boggling, given the physical geography of the area and the distances involved. The essay helps see how these strange things get started and are passed around. As the introduction to the sections states, "the rumour itself is as much a phenomenon as the information content it supposedly carries."

The only shortcoming in the book is a longish section in the middle concerning UFOs and the Media, which is mostly irrelevant to readers outside the United Kingdom. Much of the treatise makes fre-

quent references to television and music celebrities who are only known to long-time viewers of the BBC services. Anyone else quickly becomes lost in the forest of unfamiliar names and incidents, which are not explained in the text. It is assumed that the reader knows all about these things, just as most Americans would feel closely acquainted with, for example, Mary Tyler Moore.

Charles Fort himself appears briefly, in an account of his invention of the game of "super checkers" late in his life. This is a thoroughly entertaining and whimsical piece, exposing a puckish side of Fort which most readers never knew.

In summary, this most recent release from the Fortean Times people is entertaining, but much more than that. It gives all of us a chance to sharpen our necessary skills of evaluation and careful judgement.

Biological Anomalies: Mammals I

William R. Corliss

The Sourcebook Project, P.O. Box 107,
Glen Arm, Maryland 21057
ISBN #0-915554-30-5

Every time we think we know something, it is good to check reality and remind ourselves of what we don't know. This exercise saves a lot of fooling around with misconceptions, and can train us to be more careful scientific observers. The net result of

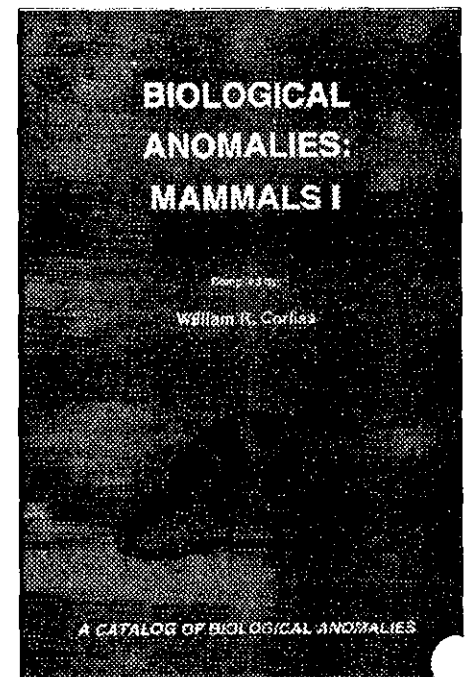

considering the gaps in our conceptions and knowledge should be a greater striving for true understanding of this apparently evolved universe.

In this spirit, a highly organized, thorough catalog of things we don't yet understand about a nearby subject is valuable. William Corliss is engaged in creating such a catalog, spanning several volumes. We recently reviewed another in the series in Vol. LI, Number 2 in the Second Quarter 1995 issue of *Borderlands*.

In this new book, one can easily look up any topic through the contents or the excellent index. The arrangement of topics follows an order which is easily understood. As an example of the information contained in the book, a section entitled "Mammals Resist Conditioning by Behaviorists" recounts two studies which should have produced results but didn't. One was on pigs, and another on raccoons. The author calmly points out how the fundamental tenets of behaviorist psychology are suspect, as a result of these studies.

Other sections cover such things as mass movements of animals, social structures, whale beaching, and structural anomalies. How porcupines copulate is also covered, which almost everyone wonders about sooner or later. The tone of the book is dry, matter-of-fact, but easily readable.

Overall, this reference work has a great deal of value, especially for those involved in biological sciences such as zoology. Any reading of this book will prove fascinating and instructive, and give plenty of food for thought.

The Gate

Featuring The 19-Tone Guitar

Neil Haverstick, P.O. Box 150271,
Lakewood, Colorado 80215

Neil Haverstick probably hails from another planet. We have gotten together and discussed this a few times. Having access to this kind of diversity certainly can cause expansion of thought processes — just contemplating the possibilities inherent in the viewpoint of such an artist will at least enhance one's observational capabilities.

Part of this album masquerades as straight, hard-driving rock and roll. So anyone who likes that sort of music will tend to be satisfied with the album right off. However, the real aesthetic pioneering in this

work are the cuts which use a different musical scale from the twelve tones we normally encounter.

Nineteen tones give us a series of fine gradations which, interestingly enough, are readily apprehended by human senses. The mathematical implications of this system are awesome. When contemplating these principles, it is easy to see that our present musical system is a purely human prejudice, and may not be fully functional in large sections of the Universe.

Later in the album, true innovation sets in. The song "Thunderbird", begins a series of songs which are expressive of a viewpoint that one would not associate with



Earthly life.

As in most Rock and Roll, there is a lot of dissonance in this music. Some would ask, why bother with it then? In this case, the answer is that you're getting the perspective of a valuable viewpoint. What is dissonant in one part of the Universe may not necessarily be so in another. Granted, the instrumentation available on this planet would not match the tonalities of someplace else, but an approximation can still help increase understanding.

Neil goes about his music honestly, and is able to blend his life here on Earth with whatever is happening in the other dimension of the Universe which he can contact. Because of this, *The Gate* is an important communication. ■

Reviews by Michael Riversong,
QI Consulting, PO Box 2775,
Cheyenne, Wyoming 82003.
(307) 635-0900

Scientific Alternatives in Health Exist Now!



Learn about the latest
research from around the world
in the field of medicine.

- Effective treatments for cancer, AIDS, and other degenerative diseases
- The latest in Homeopathy, Energy Medicine and physics

You cannot find this range of
reliable knowledge anywhere else.

For subscription information
call or write today:

Explore! Publications

P.O. Box 1508, Mt. Vernon, WA 98273

Telephone: 360•424•6025

Fax: 360•424•6029

E-Mail: ExplorePub@aol.com

Major Credit Cards Accepted:
1•800•845•7866 (orders only)

Sample issues available:

U.S., \$3.00 per magazine (postage)

Int'l, \$5.25 per magazine (postage)



On the cutting edge
of the future.

The Four Elements

in Medical Astrology

by Judith A. Hill

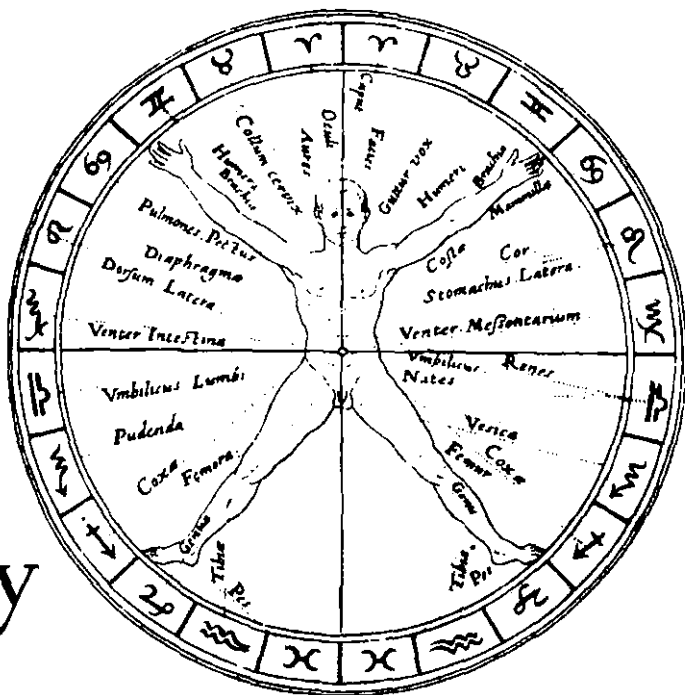

THE four elements of antiquity can be seen as a structural thread running through theoretical realms as diverse as physiognomy and Jungian psychology. However, it is in western medical astrology that the four elements stand alone in purest form, unencumbered by abstractions and theories imposed by the less physically oriented sciences. To acquaint the reader with these four elements and their use in early western medicine is the purpose of this article. First, we must introduce a few basics.

The four elements represent four planes of matter (and much more as will be described later). Classical astrology assigns each of the twelve zodiacal signs to one of the four elements: Fire, Earth, Air, or Water. The Fiery, Airy, Watery, and Earthy signs form our first and simplest description of zodiacal types useful to the early physicians. At birth, the weight of planetary distribution within each of the elements paints an astrophysical portrait of the elemental balance within both psyche and body. An observation of the planetary birth map allows us to discover the weakest elements in our physical and psychological makeup and also the most dominant. Frequently, we emotionally feel and physically see the dominant element of a friend before perhaps guessing their more particular zodiac sign type.

However, what exactly are these four elements? In fact, the four elements can be viewed esoterically, spiritually, psychologically, and physically. Fire, Earth, Air, and Water describe four levels of concretization of matter, four states of awareness, four temperaments and four types of matter within the chemical-molecular universe. This explains why the astrologers, Jungian psychologists and medieval physicians have each defined the four elements variously and utilized their knowledge of them for quite separate purposes.

THE ELEMENTS AS LEVELS OF THE CONCRETIZATION OF MATTER

In the most arcane sense, the elements refer to four levels increasing concretization of matter: photon, particle, atom and molecule. One can think of this concretization process as the journey of light (the photon, as the Fire element) from complete freedom (Fire) into gradually denser and more predictable forms, represented first by Air and then Water; until it finds itself "trapped" in the densest plane of the molecule, symbolized as the stodgy, reliable Earth element. As the photon journeys from creation towards material expression (particle, atom molecule), it gathers weight experience and form while sacrificing the playfulness and freedom of the photon and particle.

THE FOUR ELEMENTS AND THE FOUR WORLDS

The four levels of concretization of matter directly correspond to the Four planes, or worlds of the Cabalists. Their highest or Spiritual World, Atziluth is the world of emanations and archetypes. Atziluth corresponds best with the photon and with the Fire element. The second plane, Briah, constitutes the world of thought and creation. Briah belongs to the world of particles and to the thinking element Air. Similarly, the malleable Astral World, known to Cabalists as Yetzirah, the world of formations, corresponds to the atom and the receptive, impressionable and feeling oriented Water element. Last, the Physical Plane (or Chemical-Molecular Plane) is the realm of the molecule and is represented by the densest element Earth. Cabalists know this fourth world as Assiah, the world of action and the world of matter. As denizens of Assiah, we find ourselves at present confined largely to the laws of the material plane.

THE FOUR ELEMENTS AS FOUR TYPES OF CONSCIOUSNESS

The four elements are also commonly described as four types of consciousness. Jung, who studied astrology and read horoscopes, adopted these traditional four awarenesses as his famous four psychological types. However, these four types are neither Jung's invention, or anything new to astrologers whom have used them for millennia.

Fire symbolizes pure being, the sense of "I", and the life force. It is direct experience. Jung made this his famous "intuitive" type. Air represents the intellect. This is the world of thought, language and abstraction. Its mode of consciousness is detached observation. Jung renamed Air his "thinking" type. Our receptive feeling function is Water. Emotions and instincts arise from this level. Water is responsive and subjective experience. A person with this form of type of awareness Jung termed a "feeling" type. Earth represents sensation, and the body. This is the densest of the four levels and corresponds to body consciousness, materiality, survival and the structuring body building function. Jung christened Earth as his "Sensate" type.

THE FOUR TEMPERAMENTS

Medieval physicians classified four "humors" of the body, and associated these with four physiognomical and temperamental types termed choleric (Fire), Sanguine (Air), Phlegmatic (Water) and Melancholic (Earth). We do not have the space here to commence a detailed discussion of these four humors and corresponding temperaments. It is enough to say that the four temperaments although also physiognomical, do roughly correspond to Jung's four astrologically based psychological types, although in some writings the Melancholic or Earth type is viewed as entirely negative, which is inaccurate.

In this system, a balance of the four "humors" produced a balanced temperament and a state of good health. Disease was a manifestation of an imbalance of these humors. A similar idea continues today in modern Ayurvedic practice, with one exception. The four "humors" of the body have been grouped into just three "doshas", or elemental forces. Air becomes Vata, Fire is Pitta, and Water and Earth combine in a single "heavy" humor known as Kapha. The description of the Kapha type appears to combine the qualities of both the traditional western Phlegmatic and Melancholic psychological temperaments. Fruits, vegetables, medicines, and activities are also classed under each dosha. Healing is assisted by subscribing to a regimen that balances these doshas. If you are too hot, then you must cool off. If you are too damp, then you must dry out, and so forth.

THE FOUR ELEMENTS AS FOUR TYPES OF MATTER

This is very simple. The element Fire manifests as fire. The element Air as air. Water is water, and Earth is earth. However, their correspondences to the physical body are a bit more complex.

Fire is the Chinese "Chi" or life force, also the energy and the digestive force. Fire releases energy. Therefore, the metabolic and fuel burning activities of the body take place through activation of the Fire element. The action of Fire is hot, light and dry.

Air governs the little known electrical forces and electrical

connections within the body, neurotransmission, motion, oxygenation of the blood, breath, language and motion. Its action is cold, light and moist (some texts say alternatively cold, light and dry).

Water rules the waters of the body. This includes phlegm, lymph, semen, and all other bodily secretions and fluids. The moist and protective mucous membranes of the body are a function of the Water element. Also, our memory function is related to water because water is the most impressionable of elements. The action of water upon the body is cold heavy and wet.

Earth governs the minerals within the body, the bones and the building up of a bodily structure. Earth also holds in energy, and has much to do with stamina, food storage, body building, and longevity. Earth is warm, heavy and dry (the Earth sign Taurus may be an exception, producing more a warm and moist condition). Natives of Taurus, the preeminent earth sign are noted for being human greenhouses, always maintaining a warm body temperature.

THE RATE OF MATTER IN MOTION: THE THREE MODES

In the simplest context, the four elements are four states of matter: that of light, liquid, gaseous, and mineral. As said earlier, each of the twelve signs are assigned to one of the four elements. This classification is accomplished in the following manner:

Fire: Aries, Leo, Sagittarius.

Air: Gemini, Libra, Aquarius.

Water: Cancer, Scorpio, Pisces.

Earth: Taurus, Virgo, Capricorn.

However, there is a further sign classification of great import. Because matter moves, we must sub designate each element according to the rate of matter in motion. This produces the three Modes or Quadruplicities of classical western astrology. It is these Modes that describe the rate of matter in motion. These three rates are known as the Cardinal, Mutable and Fixed modes. For instance, Fire igniting is Cardinal Fire. The concentrated Fire of an oven is Fixed Fire in action. A wildfire would be of course Mutable Fire, or moving fire. Cardinal energy always initiates each season. Fixed energy always occurs in mid-season, such as midsummer, when the energy of Fixed Fire (heat, dryness) is most concentrated. Mutable energy is transitional and dispersive, always occurring at the end of a season as it gradually changes into the following quarter.

The Cardinal signs of astrology are those signs that mark the two solstice and two equinox points: Aries, Cancer, Libra, and Capricorn. They are active and initiating in nature (one may argue the reverse in the case of indecisive Libra if one fails to reason that Libra initiates the Air qualities of abstract contemplativeness, and detached observation). The Fixed Signs are the stubborn four: Taurus, Leo, Scorpio and Aquarius. Mutable signs are noted for their versatile, flexible and sometimes unstable natures: Gemini, Virgo, Sagittarius and Pisces.

IMBALANCES OF THE FOUR ELEMENTS AND HEALTH

Imbalance of the four elements occurs in one of two ways:

deficiency or excess. Your planetary birth chart is the tool used by astrologers to divine the quality and amount of each element in the birth chart. Until the mid 17th century, physicians were required to have passed their exams in astrology. Each physician was expected to be fluent in the diagnosis of planetary charts from the medical perspective. The complex nature of this astro-medical analysis is beyond the scope of this article. Instead, I would like to present a listing of common complaints associated with both the excesses and deficiencies of each element. A few interesting cases from my own files will round out the discussion.

FIRE: EXCESS

Dehydration, hyperactivity, hyperthyroid, baldness, emaciation, great hunger, brainstorms, aneurysm, heart attack, high blood pressure, stroke, overheating, sunstroke, insomnia, liver disturbances, egomania, compulsive behaviors, itch, inflammation, alcoholism, boils, acne eruptions, arterial and blood vessel complaints, hyperstress.

ANTIDOTE: THE WATER ELEMENT

Treatments: Hydration with cool liquids, cool baths, cool moist herbs and foods, sweet and moist foods, fruits, green color, calm music, avoid hot spicy and oily foods, avoid red colors, stay away from hot sun, avoid overheating, apply liver tonics and purification, strengthen arteries, avoid temper and excessive excitement.

FIRE: DEFICIENCY

Weak, listless, hypoenergetic, overweight, low blood pressure, depression, poor eyesight, poor self esteem, fatigued, poor digestive fire, weak heart.

BALANCE: APPLY FIRE

Treatments: Exercise, heart and blood tonics, red stones and colors, dance and play therapy, brass instruments and rousing music, iron, spices, improve circulation, develop muscles of upper body, sing, paint.

Field Notes: Fire

Here is an interesting case of Fire excess extracted from my files. A friend of mine gave birth to a redheaded baby boy. Soon after birth he became badly dehydrated, fitful and would rage all night. He had great difficulty sleeping. His birth chart showed not only an excess of the astrological hot and dry fire signs but none of the balancing moist water signs, plus also a very prominent Mars near the Ascendant at birth. (Mars of course, is a hot and dry planet.) Upon hearing this, the mother had the invention and insight to do something to bring the Water element into the baby's energy field. She began soaking him in a comfortable bath just before bed! Baby loved his baths and afterward slept sweetly, his crying problem greatly diminished from the onset of the water "experiments".

Fire deficiency frequently manifests as a lack of confidence and a weak ego. The individual lacks playfulness, warmth, creativity and pizzazz. They may also lack the ability to initiate activities. One case of deficient Fire combined with excess Earth is most interesting. This man suffered from an absolutely compulsive need to seek stimulating entertainment and social events. He craved stimulation (Fire) from outside because he could not find it within. However,

despite his constant socializing, he was personally so introverted and reserved that he could hardly carry on a conversation and had the greatest difficulty expressing himself in any way, or displaying affection. Outwardly, he appeared cold, rather lifeless and unresponsive. Inwardly he possessed much stamina (Earth), and was a capable long distance runner.

AIR: EXCESS

Scattered, nervous, excess talking, mentally unbalanced or fatigued, mental flights, hyperactive, restless, cold, anemia arthritic, hypersensitive, emaciated, unstable, thin and balding hair, lacks personality force, weakness, self destructive through irregular living, indecisive, scattered.

ANTIDOTE: EARTH

Treatments: Good nutrition, Mineral baths and tonics, warmth, nature, massage, practicality, gain weight, business training, weight lifting, warm solid and well prepared meals every day, warm grains, root foods, calming music, quiet time, sleep, sedatives, nerviness and mental rest, yellow and blue colors.

AIR: DEFICIENCY

Asthma, sub oxygenation of cells, lung weakness, poor judgment, lack of humor, listless, overly intense (air lightens), slow in thought or movement, poor circulation, weak heart action, low blood pressure.

BALANCE: AIR

Breathing exercises, improve bodily oxygenation and circulation, humor therapy, views, mental development exercises, fr air, juggling, coordination exercises, speech therapy, flexibility exercises, yoga, strengthen the lungs and arms.

Field Notes: Air

Over the years a number of clients have arrived with deficient Air element. I always then ask the question "Do you have asthma, shortness of breath or bronchitis?" Their reply is typically affirmative. It is evident that Air deficient people do indeed lack oxygen! Lack of air may also manifest on the mental plane as a lack of levity, comparative reasoning or objectivity. A recent case was that of a young woman with many talents. However, she could not acquire appropriate schooling for lack of ability with tests and memorization of facts. She simply could not learn through the standard western educational method. She took readily to my suggestion that she might do better in an experimental type of educational setting.

Air excess produces the scattered, unsettled and over talkative individual. This type spurns routine and does not take care good of themselves. Smoking cigarettes, irregular sleeping, sexual and eating habits, plus frequent job changes all give rise to fatigued nerves and an unsettled mental condition. Although seemingly able to burn the candles at both ends without mishap, the Air type will burn themselves out early and not infrequently expires before their time. Tuberculosis, nervous breakdown, mental disturbances and malnutrition are complaints common to excess Air, especially when coupled with a deficient Earth element. In cases of excess Air, the Ayurvedic physician insists on a stable routine combined

warm grains, oils and vegetables. Cold foods and beverages are forbidden as are excesses of all kinds.

WATER: EXCESS

Water retention, bloat, nausea, fermentations, yeast, sluggishness, low energy, oversleeping, drowsy, oversexed, indulgent, dependent and addictive behaviors, obese, paranoid, tender swellings, pain sensitive, overly emotional and childish, lazy, depressed, chills, weak eyesight, poor structure and posture, weak teeth and bones, shuns daylight, avoids reality, introversion, noise sensitivity, soft growths and tumors, breast lumps, prostrate swellings, excess mucous and other bodily fluids.

ANTIDOTE: FIRE

Treatment: Purgatives, sweats, promote urination, hot spices, exercise, dry heat, heat lamps, cognitive therapy, sunlight, laughter, warm colors, stimulation, affection. Avoid cold wet and sweet foods (ice cream and watermelon are the worst for this type), improve heart action and circulation. The Water type responds excellently to kindness.

WATER: DEFICIENCY

Insomnia, restless and overactive, dehydrated, dry, inability to relax, constipated, infertile, low libido or sex satisfaction, fears or alternatively craves intimacy, low appetites, insensitive, memory dysfunction, paranoia, complaints of dryness, swallowing, etc.

BALANCE: APPLY WATER

Treatments: Swim and bathe, humidifiers, drink liquids, exposure to moonlight, pearls, silver, dolphins, puddings and custards, romantic music, sleep, sedatives, psychotherapy, psyllium seed, slippery elm bark, chanting, herbal laxatives, comfrey root and similar demulcents to moisten the mucous membranes, aphrodisiacs, nurturing (receiving or giving), support groups, lakes, rivers and oceans, boating, fishing, meditating, devotional, and charitable work.

Field Notes: Water

In my work a number of interesting cases have appeared of persons born with a great excess in the water signs. In most of these cases, should a lack of the drying fire element also fail to be present, you will find the dropsical and water laden body. Two cases demonstrate water excess most effectively. One case was of a girl who spent most of her life in a semi-coma following a botched operation for brain tumor. This unfortunate individual was very sensitive, sweet and passive, and eventually passed on at a young age. A similar case of being "under water" is that of Helen Keller, born deaf, dumb and blind. She was also born with a considerable excess of planets in the astrological water signs. However, despite her unusual condition this individual achieved much and the malady appeared to be restricted to the physical condition.

Three cases of water deficiency recently observed produced individuals who suffered from a lack of inner peace. Water is the element of peace, and so this makes good sense. Both individuals were restless, suffered insomnia and found it impossible to relax or to enjoy intimacy. One friend who completely lacked the Water element and yet possessed much Fire, compulsively spent her

money and traveled. This strange behavior was symptomatic of too much throwing off type energy (Fire, Air), and not enough holding in type energy (Earth, Water). She was seized with intense ambitions that would abruptly change with the wind. Her dry and hard body completely lacked the subcutaneous fat typical of the feminine sex. In this case, a medieval physician might attempt to introduce the Water and possibly Earth elements into the body while simultaneously cooling down the Fire element, and balancing the Air element.

EARTH: EXCESS

Mental dullness, lack of mental creativity, either boring or suffers a chronic sense of boredom, withholding, laconic, over eats and overworks, the body is either sluggish and very large and heavy or very bony and emaciated (curious! The weight extreme observed will depend on a number of other factors.) Suffers dryness, constipation, dandruff, skin problems, eczema, brittle nails and cuticles (dry), mucous membranes also dry, brittle teeth, hearing problems. Unresponsive and insensitive. Generally strong and healthy on a daily level, although highly prone to chronic conditions and cancer due to toxic buildups, constipation, arthritis and rheumatism, bone spurs, hard growths, cancer. Great longevity.

ANTIDOTE: AIR, THEN WATER

Treatments: Purgatives, colonic therapy, fasting, vegetarianism, saunas, emotional and affectional development, light eating of light foods, flexibility exercises, dexterity exercises, oil rubs and compresses, conversation, variety, travel, mental stimulation (improve mental speed, verbal and comparative faculties), humor, neurological stimulation, development of social fluidity, demulcent herbs to moisten the mucous membranes, avoidance of rich, toxic or dry foods such as meat, milk products and pastries, breathing exercises, views and flying, reading and writing, hatha yoga.

EARTH: DEFICIENT

Difficulty in gaining or holding weight or money, low stamina, weak bones and teeth, poor physical strength and endurance, weak posture and bodily structure, poor appetite, nervous, impractical, unstable, cold, insufficient immunity, hypothermia, cold body, malnutrition, mineral deficiency, ungrounded.

BALANCE: APPLY EARTH

Treatment: Minerals, mud and mineral baths, nature, sitting on the earth, hatha yoga, stable routine, weight lifting, aikido, Tai Chi and other exercises that teach one to hold in energy, warmth, massage and touch, steady jobs, herbal therapies, calcium, good food, gardening, building, pottery, sculpture, business training and money management, improve attention to clothing and appearance.

Field Notes: Earth

As in other elements, an excess or deficiency of earth becomes more apparent with the simultaneous appearance of an opposite condition (excess/deficiency) for another element. Two individuals that spring to mind possessing excess Earth and deficient Fire are very simple and uncomplicated personalities, slow moving and yet

thorough and dedicated in all endeavors undertaken. Their bodies are also dense and sluggish, as is their speech. One of the two suffered a hearing complaint, typical of earth signs. Their bones, hands and feet were large, and clumsy. Physically, they were always very warm. Remember, earth is a greenhouse — it holds in heat, whereas fire lets it out! Earth is a very tough, dense element and so are excessively earthy people. It is not therefore unremarkable that a number of the great heavy weight boxers were (including Rocky Marciano, Foreman, Frasier and Muhammad Ali) were born in earth signs. It would be interesting to make a statistical study of earth signs in the birth charts of boxers. Curiously, other Earth type people I've observed are of the bony "ectomorphic" category. This is due to the rulership of Saturn over the earth sign Capricorn. This Saturnian type Earth element person may be bony but they are dependably tough and strong, with excellent stamina. Both Earth types make excellent gardeners.

A case of earth deficiency with strong air came with a man who was finding it impossible to find a home. And although he made good money, stability evaded him. Neither did he understand money or the material universe very well and was ever in danger of being conned by the more worldly wise. Mentally he was agitated and fearful of dealing with life's realities. Remember, Earth signs deal with the earth plane. Sometimes he would forget to eat, and possessed no materialistic desire to own anything. His body was exceptionally fragile, and he suffered a lifelong trouble with stamina (Earth element), rendering him incapable of prolonged physical labor. He could do anything a little while, but just could not physically keep up on the long hike. It was important to him to spend time in nature (earth) everyday. Nature calmed his sensitive nerves and provided the quiet he longed for more than anything else.

This man tended to insufficient digestion of nutrients leading to mineral deficiencies and benefited from minerals taken through sea water extracts. Earthy staples such as grains and potatoes were favorite foods although he could not eat too much at one sitting without difficulty. It was important for him to lift weights only to maintain his delicate frame in good health. Curiously, he was greatly attracted to granite and other heavy rocks and loved to sit on boulders overlooking natural scenes. As a rule, he suffered greatly from cold and seemed unable to produce or contain his own heat. Hypothermia was ever a danger. The only way he could warm up was through application of hot baths and a glass of hot tea before bed. In all probability, a medieval physician would have him apply hot earth, mud or mineral compresses instead to replenish the missing earth element.

THE ELEMENTS IN COMBINATION

The above descriptions are uncomplex compared to the actual



practice of medical astrology. The four elements are never observed in a vacuum. Any elemental excess present in the planetary birth chart automatically signals the reader that some other element must be deficient. This fact gives rise to several classifications of deficient/excess element pairs, too numerous to discuss in this present article. Additionally, the entire birth chart is taken under consideration. The planets in particular are observed for sign placement, and also according to their temperature, hearkening back to, and supportive of the four elements. For instance, Mars is a hot and dry planet and Saturn is cold and dry. However, should you be born at night, with Mars appearing above the horizon and in a cooling water or earth sign, then the normally destructive nature of Mars is toned down through this cooler, moister situation. Similarly, Saturn benefits by placement in a warming day birth, especially when placed above the horizon in a warm masculine sign.

Field Notes: A Case of Elements Acting Together

An extremely interesting case recently came to my attention. This is the case of a young man with an excess of both Earth and Fire, acting in combination with a condition which can only be described as disturbed Water. The disturbed Water element was brought about in the following manner: the moist Moon was in the hot and dry Fire element, and strongly afflicted by Mars, a hot, drying planet. To compound matters, Mars was the only planet located in the Water element. This created an extremely dry and agitated condition within the body. Repeatedly, the boy

hospitalized for severe dehydration. He could not drink or eat and his stomach rejected not only foods but liquids. Severe constipation, difficulty swallowing and partial deafness accompanied the foregoing symptoms. Remember, water rules the mucous membranes, and in this boy's case Water is not only weak but suffers from an intrusion of the Fire element, further damaging Water's soothing and moisturizing properties. The excess of Earth in the birth chart created a dry, dull and listless appearance. The Air element was also weak, exacerbating the combination of excess Earth and Fire with disturbed Water. As a rarefied element, Air acts to assist the burning rate of Fire, which otherwise smolders intensely without enough Air. Also, a satisfactory Air element would prevent the Earth element from becoming too heavy and absorbing. Could the ancient Elemental medicine bring relief for this unfortunate case?

CONCLUSION

The medical use of the four elements has never died, continuing to the present time in dual form. In the east, the respected practice of Ayurvedic medicine relies heavily upon the consideration of the doshas (elements) for diagnosis and treatment. In Europe, the entirety of medical astrology inclusive of the four medical elements was forced underground at the close of the 17th century. However, despite the prevailing opposition against the practice of western astro-medicine, its use and knowledge have never died and its principles continue to be utilized by a small number of licensed western physicians.

Davidson's excellent Medical Lectures, (out of print) and Cornell's (Dr.) Encyclopædia of Medical Astrology are but a few names in point. One cannot peruse the contents of these writings without being suitably impressed with the complexity and sophistication of 20th century medical astrology. Other interesting examples might be Dr. Millard's Case notes of a Medical Astrologer, and Carl Jansky's Modern Medical Astrology.

Those that practice medical astrology are certain of its efficacy. Personally, I've witnessed cases where the cause of a hidden health complaint eludes the doctors while the answer sits crystal clear in the horoscope waiting to be seen by all. Eventually, and after many tests, if not enormous cost to the hapless patient, the doctors finally discover the source of the mystery problem to be identical with the astrologer's diagnosis. Could it be that the ancient physicians were on to something after all? ■

JUDITH A. HILL is a second generation astrologer with 26 years of consulting experience. She is the author of *The Astrological Body Types: Face Form and Expression*, (Available from Borderland Sciences, \$17.95 + p&h). She served as the educational Director for the San Francisco NCGR and as faculty member of the Institute for Stellar Influence Studies. Perhaps best known for her innovative work in astrological research, she has lectured at many conferences within and without the astrological community. Her international publications of scientific research ("The Mars-Redhead Link" with Thompson, "The Regional Factor in Planetary-Seismic Correlation" with Polit, etc.) have been widely acclaimed as major breakthroughs in the field of astrological research. Judith achieved 100% accuracy in the matching of five anonymous birth charts to biographies in a 1986 skeptic-designed NCGR sponsored contest. She currently authors the series "Astrology, A Philosophy of Time and Space" for *Sufism* magazine. Judith runs a full-time consulting practice in Portland, OR, and specializes in Vocational Astrology.

Leading Edge Research Group

P.O. Box 7530

Yelm, Washington State 98597

Since 1988, Leading Edge Research Group, formerly known as Nevada Aerial Research, has released over 12,000 pages of materials to researchers worldwide in the form of books and the main forum *The Leading Edge*, a monthly worldwide journal of 120 pages with a reputation for groundbreaking excellence. A sample issue is \$12. A catalog containing descriptions of all LE issues and books from 1988 to present is \$8. Leading Edge Research is also the source for the famous *MATRIX* books: *Matrix II: The Abduction and Manipulation of Humans Using Advanced Technology*, by Valdmar Valerian, 1992, 661 pg, 8 x 11 Velo, Index, \$52.50ppd; *Matrix III: The Psycho-Social, Chemical, Biological and Electronic Manipulation of Human Consciousness* by Val Valerian, 1992, 971pg, 8 x 11 Velo, Index, \$55.00 ppd; *Matrix IV: The Equivideum- Paradigms and Dimensions of Human Evolution and Consciousness*, by Val Valerian, 1994, 1134pg, 8 x 11 Velo, Index, \$65 ppd. *The Leading Edge* and the *Matrix* books have been and will continue to be among the best on the planet! Send for free info pkg. *Matrix III Volume 2*, 1014pg, Oct 1995, \$59ppd.. *Avoiding Extinction* by Dr. Dan Hall, \$24.95. OVERSEAS WRITE FOR PRICES.

Exotic Research Report



Dedicated to Independence

Prepared for the 21st Century?

Mind Control, Weather Control, NonLethal Weapons, Suppressed Cures, Gulf War Syndrome, New World Order... sounds like science fiction! Yet it IS all happening... TODAY... and we cover it! If you feel that a lot is going wrong, and nothing makes sense anymore, *you are not alone.*

But you can make a difference...

Be informed. **SUBSCRIBE** to *Exotic Research Report* for information that can change your life!

You will find the answers here!

SUBSCRIBE TODAY!!!

US: \$30 Canada: \$35 Others: \$55



Exotic Research
PO Box 5382B
Security, CO 80931
or call (719) 630-0693

In Memorium

A New Assignment for a BSRF Old-Timer

ROBERT A. McCULLOUGH

1921-1995



by Trevor James Constable

THE passing from this life of Bob McCullough in November of 1995, removed from our midst a borderland worker and thinker of rare talents. Bob was a BSRF member for more than four decades. For many years, whose legacy and benefits I cherish, we were as close as twins. We took turns at teaching and guiding each other as we explored borderland science and technology. Bob was one of those diamond-precious men who could function effectively in his conventional scientific profession as a biologist, while sustaining a dynamic interest in borderland areas. He was at once the square and the circle.

Bob McCullough's career was initially conventional. Born in Duluth, Minnesota in 1921, he was raised by decent, honest, straight-ahead Americans, the kind of people who are the salt of the earth. Bob's outlook was ruled by decency and openness as a result. After graduating from high school in Park City, Utah, in 1939, he served from 1940 until 1945 in the US Army. Discharged as Sergeant McCullough, his life continued along conventional lines as he married his wife Phyllis in 1945, and began his family of five children. He attended Utah State Agricultural College, graduating in 1950 with a master's degree. He was just a few credits

short of his doctorate, which he never got around to completing.

Still going along conventional lines, he put in two years (1951-52) with the New Hampshire Fish and Game Department at their Durham test station. He heard fascinating rumors and reports about the innovative biological work being done in Maine, at Orgonon, by Dr. Wilhelm Reich. When an opening came for a biological scientist on Reich's staff, Bob applied and was accepted by the great man after a personal interview. From this point on, his life would be decisively changed. His two years as a scientific aide to Dr. Reich provided the milieu in which Bob's unique gifts would find both scope and development. Dr. Reich made an excellent choice when he engaged Bob McCullough.

Bob was an extremely sensitive man, able to feel directly etheric fields and flows with his hands, and also with his face and forehead. His tongue was hypersensitive bioenergetically, and of enormous practical value in working with orgone accumulators and cloudbusters. He had a fully functioning First Orgonotic sense, to quote the term coined by Dr. Reich. Only a very few people ever have such a level of sensitivity, due to the desensitizing influences of cultural fixations regarding child-rearing.

Extremely perceptive as well as scientifically trained, Bob found himself at Orgonon working with the most astute scientific observer he would ever know — Wilhelm Reich. This was an historic encounter for Bob, with an historic personality. Dr. Reich would from time to time, gently chide and guide Bob, and point out to him when he was acting irrationally. That is something that often happens when you deal with things bioenergetic. Bob's employer was thus also his teacher and on-the-job therapist. All his life, Bob McCullough would stand in awe not only of Reich's observational powers, but also of WR's incredible awareness.

"To drive to Farmington or some other nearby community with Dr. Reich was usually a memorable experience" Bob once told me. "His awareness was phenomenal — as though it were 20 miles out in front of him." WR always seemed to know in advance of unannounced store closings or other irregularities that cropped up during these little trips. At Orgonon, WR repeatedly drew Bob's attention to incredibly subtle happenings, such as the mysterious deposits that slowly accreted on Orgonon buildings, which had eluded even Bob's trained observational powers.

His invaluable service with WR lasted two years, and included the horrific period at Orgonon when nuclear radiation, from radium and cobalt samples, clashed with the concentrations of orgone energy in accumulators and orgone rooms. Now known as the Oranur period, it was an unforgettable time. Countryside and vegetation for miles around were affected. Buildings on Reich's estate glowed at night, and UFOs became a baleful presence. Bob McCullough lived right through this historic period, and wrote many of the protocols as WR grappled with a flood of unprecedented happenings.

For a man of Bob's extreme sensitivity, it was a time of great strain and anxiety. Too much that was too new, came too quickly. Immediately after this tumultuous period, Bob drove a cloudbuster truck to Tucson, Arizona for the epic raining of the Tucson area, that is now history. Operating cloudbusters during this project, Bob found that these devices provoked the appearance of UFOs. This was borderland science in action, as weird spheres and fusiform objects whizzed around the mountains and across the desert skies, noiselessly and at high speed.

During this time, he suffered a stroke of sorts while operating the cloudbuster, and this brought his historic career with Wilhelm Reich to a close. Ever afterward, Bob was cautious and conservative about using cloudbusters. He was to drag one leg for the rest of his life as a reminder and legacy of his Tucson disaster. Bob did not see UFOs again until he got hold of my crude 1958 book, *They Live in the Sky*. In the picture section of that book were infrared photos of the same type of bioforms that he had provoked with the cloudbuster in Arizona. This impelled him to make my acquaintance, and we enjoyed a solid and happy friendship thereafter until his passing.

I have watched Bob McCullough operate cloudbusters many times, and I regard him as the most skillful, perceptive and effective weather engineer I have ever known. His observational powers were outstanding. I have always considered it one of life's privileges to have been taught by him, and to have been phased into my own weather engineering career under his guidance. In all the world, there was no one with his capabilities and unique experience, of which he gave unstintingly. My debt to him is huge, for without his

teaching and his experience, I would have been like many other would-be cloudbuster operators: floundering in my own multiple stupidities and ignorance. From all this, Bob delivered me.

Bob McCullough was a big and powerful man, but gentle, kind and patient. He was a wonderful teacher. New knowledge he absorbed like a sponge, and he profoundly expanded his world view through Rudolf Steiner's work. For many years, we corresponded by cassette tape. This modality allows lines of thought to be taken as far as one wishes, without the burdens of written composition. We exchanged uncounted scores of such tapes, to our mutual benefit. We truly enjoyed each other.

After the health debacle that ended his service with Dr. Reich, Bob went back to the US Army — this time as a biological scientist at the Dugway Proving Grounds in Utah. He was working on chemical and biological weapons — a drastic reversal of his life-giving work with Dr. Reich. Bob retired in 1974 and went to Costa Rica to live for eleven years. Returning to the U.S. in 1988, he settled finally in Horseshoe Bend, Arkansas, where he passed away on 26 November 1995, after a long period of indifferent health.

Bob McCullough leaves behind Phyllis, his wife of fifty years. His five children, Michael, Becky, Rory, Bruce and Debbie, are all going to miss him. He was a devoted family man, and a loving and tender father and grandfather. He will live on in my memory as friend, teacher and co-worker. Borderlanders everywhere will join in extending sympathy to his family. Bob McCullough was honest, honorable and upright, and he lived out this most recent incarnation the old-fashioned way — as a gentleman. He is well prepared for his new assignment.



TJC and Bob McCullough, Banning, California, 1985.

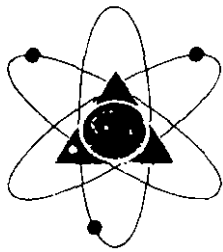

Third

Announcement and Call for Papers

International Symposium on New Energy

"An Exploration of Free Energy Generators"

April 25-28, 1996

Denver Hilton South • Denver, Colorado

For Professionals, Industry, Lay People, and News Media

Over Forty Speakers on Cold Fusion, Anti-gravity, Zero Point, Magnetic Motors, Transmutation, Hydrogen, etc.

Dennis Cravens, Ph.D.* – Patterson Fuel Cell**

Mark Hendershot – Hendershot Motor

Harold Putoff, Ph.D.* – Zero Point Energy

Edgar Mitchell, Ph.D. (former Apollo astronaut)* – New Energy Update

Jim Griggs, Ph.D. – Hydrosonic Pump**

Eugene Mallove, Sc.D. – Cold Fusion Update

Tom Valone – Free Energy and Propulsion

OTHER SPEAKERS

Harold Aspden* (Ferromagnetics) • Paulo Correa, Ph.D. (Abnormal Glow Discharge Reactor**) • Robert Emmerich (Measuring Energy) • Hal Fox (Cold Fusion**) • John Grow (Anti-gravity) • John Hutchinson (Anti-gravity) • Russ James (Emission Reduction) • Don Kelly (Free Energy) • Ron Kovac (Transmutation) • Win Lambertson (Solid State**) • Peter Linderman* (Thermodynamics) • Jeanne Manning (Energy Revolution) • Roy McAllister (Hydrogen) • Andrew Michrowski (Free Energy in Homes) • Bill Muller (Magnetic Motors) • Brian O'Leary, Ph.D. (Miracle in Void) • Dale Pond (Keely Motor) • Wing Pon (Free Energy Theory) • Troy Reed (Magnetic Motor) • Pierre Sinclair (Gravitational Magnetic Drive) • Bert Werjefelt* (Magnetic Motor) • Dan Winter* (Gravitational Energy) • Charles Yost (Electrostatic)

* Accepted if schedule permits

** Over Unity

REGISTRATION FEE

\$200 before March 1 • \$250 from March 1-April 1 • \$300 after April 1

International Association for New Science

1304 S. College • Fort Collins, CO 80524 • (970) 482-3731 • FAX (970) 482-3120

COMING UP

IN THE NEXT ISSUE OF

BORDERLANDS

Broadcast Power of Nikola Tesla
Homeopathy: The New Knowledge
Infrasound

Radionic Experiments with Plants

The Vital Force

DON'T MISS IT!

Suppressed, overlooked and unreported information on

- conspiracies
- health
- future sciences
- the unexplained
- the new world order
- Earth's ancient past

Tune into the news you are not supposed to know

Subscribe to:

NEXUS MAGAZINE

\$25.00 for 6 issues per year

\$5.00 for sample issue

PO Box 177, Kempton, Illinois 60946, USA

Tel: (815) 253-6464 FAX: (815) 253-6300

The Golden Mean

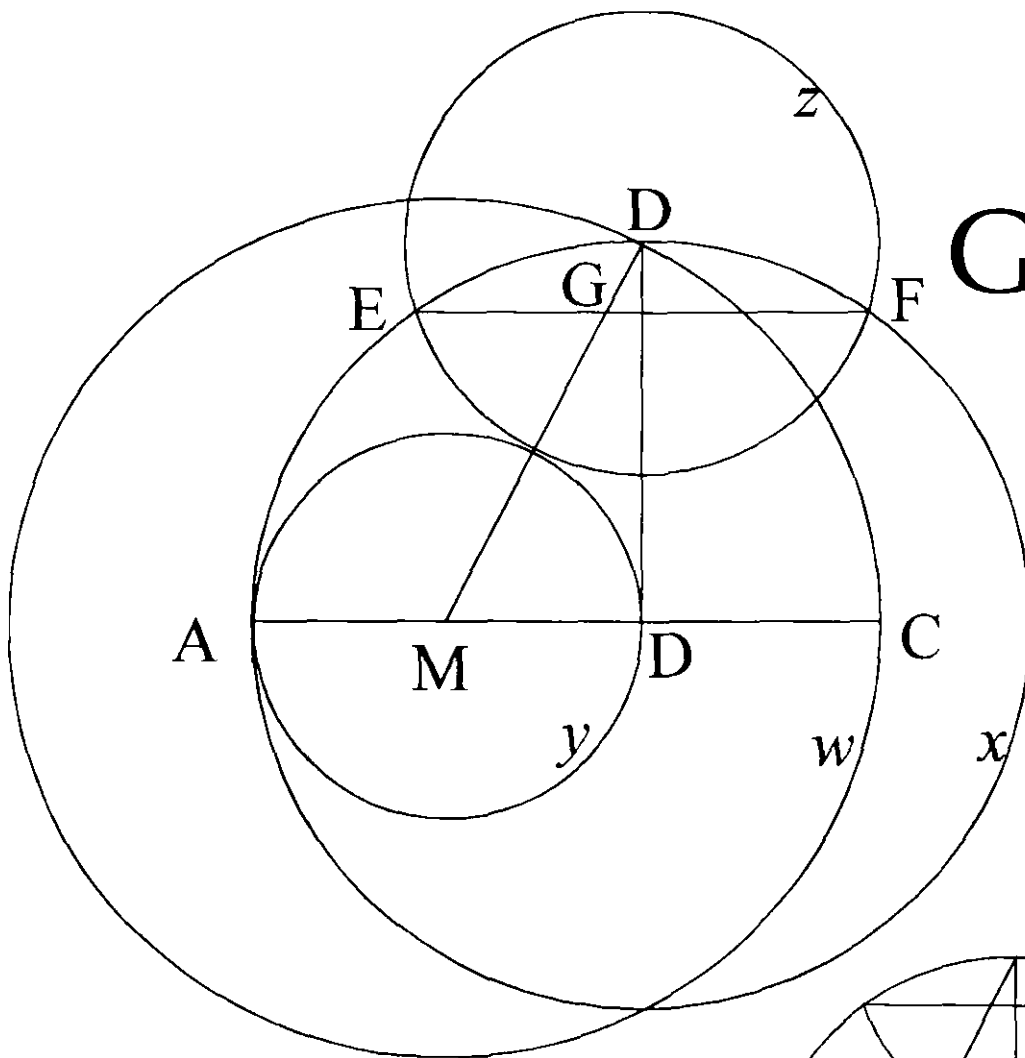

The Internet, is the vast, new frontier of communication and information presentation. ASIS provides a network and a "mean" point from which you can embark on your quest for relevant information. As a publisher, ASIS provides a structure that facilitates the global community's access to the information you present. We put BRSF on the World Wide Web.

<http://www.asis.com/brsf>
Contact ASIS for Web Page Design
and Electronic Publishing.

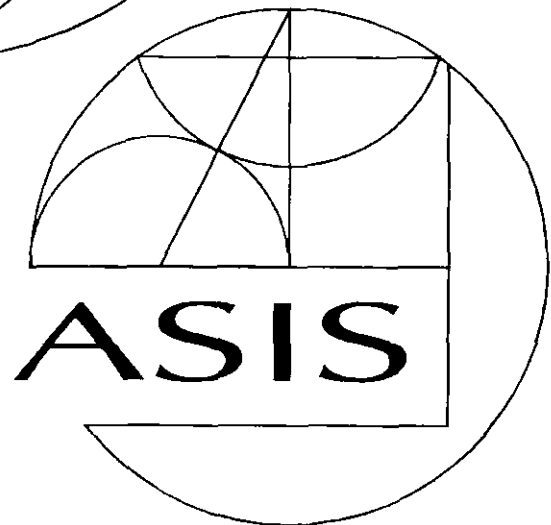

TELEMEDIA

<http://www.asis.com>
info@asis.com

7 0 7 9 2 3 3 3 5 6



The Pundit Curmudgeon

Verbal Meanderings

Including a Discussion of the International Tesla Society's
1995 "ExtraOrdinary Science" Conference

© E.D. O'Brian 1995

ONE of the prerogatives of being the author of a column should be the privilege of rambling on about a collection of more or less related yet clearly unrelated topics. This column is

intended to test whether this privilege exists.

If it does then it is the time and place for some good old fashioned self congratulations. The reason for this was set forth in an article in the Portland Oregonian - which the author lost - stating that a professor at the University of Washington has received a DOE contract under the terms of which he will be paid heap big bucks for studying the use of liquid nitrogen as a fuel for short range vehicles.

Since a valid new concept can originate with a number of different individuals at the same time or at different times there is no guarantee that the idea of using liquid nitrogen as a fuel source being investigated by the DOE was derived from an earlier Pundit Curmudgeon column. but because the contract was announced a year or so after the Borderland disclosure there certainly is a presumption as to the derivation of the DOE's inspiration in connection with this matter. It's a safe bet that the DOE has not and will not mention this publication in connection with this matter.

Peter Lindemann is a very creative, pleasant and delightful scalawag who is well known to Borderland's readers. The stinker came up with a twist on the use of liquid nitrogen which the writer should have originated. He has proposed using this composition to cool the "cold" side of Stirling and similar engines so as to, in effect, operate them in a reverse manner. Since the somewhat heated gas produced as a result of doing this will still have some "kick" there is no reason as to why it cannot be used with a turbine, a piston and cylinder type engine or any other related device to derive additional energy. If any heat - preferably waste heat - is applied to the other end of a Stirling engine the device should really move.

Peter's concept of getting a dual benefit from using a Stirling cycle engine seems so simple that someone must have previously proposed it. These engines are not exactly new. This was demonstrated at the July 1995 ExtraOrdinary Science Conference by the International Tesla Society in Colorado Springs. A man who was apparently not connected to the conference had a series of historical Stirling cycle engines merrily operating just outside of the

physical area of the conference. Stirling power has more than adequate merit, (after all it is "sterling"), particularly when used so as to get a dual utility from the "energy" employed as suggested by Peter, to warrant DOE action. Don't ever expect to ever hear of the latter until the DOE undergoes a metamorphosis.

At the conference there was an inspiring and frightening report by a Mr. Wayne Green, the owner of the a magazine entitled Cold Fusion which reports on developments in the field designated by this title throughout the world. Judging from what he said there is good reason to believe that cold fusion as developed outside of the USA stands a good chance of being used to produce most of the world's electric power. His comments on the absence of domestic research on this topic as a result of DOE and its director deserve bona fide - and not a politically inspired and governed - Congressional hearings and other remedial and probably punitive action.

Apparently, because the director of the DOE wrote a book taking the partisan position that cold fusion is impossible. In furtherance of his personal views the learned director has apparently taken the position that nothing should be done which might prove that he was wrong in taking this stance. In implementing this policy he apparently had decreed that any academic institution which spends any energy in investigating this topic loses all present and future DOE financing. As this has its expected effect here in the US, the rest of the world is apparently charging full speed ahead toward making cold fusion a viable reality.

The fact that derogatory statements of the type indicated were made at the conference can be expected to influence the DOE. Any subject matter mentioned at any Tesla Society meeting or publication probably has already been noted as being unsuitable for any activity by the DOE or by any institution receiving any form of DOE assistance. Unfortunately this will probably be the case if the subject matter is mentioned in any magazine such as this which is at least partially concerned with the topics related to those of concern to the Tesla Society.

Unfortunately a Government vs. People attitude permeated much of the Tesla Society conference. A distrust of both the FDA and the DOE was inherent in connection with many of the lectures. One could easily have concluded from what was stated and the reactions of the audience that the FDA has all of the detrimental characteristics of both Hitler's SS and Gestapo. This is a damn shame.

No one present at the conference seemed to recognize that the blame for the action of the FDA belongs with Congress. It, and r

the FDA, is responsible for the laws governing the operation of the FDA. Of course this does not forgive anyone affiliated with the FDA for bona fide mistakes in judgment occurring in a good faith attempt to carry out the Congressional mandate of the law under which the FDA operates. Neither does it justify intentional conduct clearly in violation of this Congressional mandate.

Nowhere was this disdain for the FDA as apparent as in connection with a "surprise" speaker - according to the writer's questionable notes a Dr. Bear. He exhibited and briefly turned on his version of a "Rife" machine. An officer of the Tesla Society (whose name the writer did not adequately hear) indicated that details of this machine would be published in the next available issue of the Tesla Society's magazine. The issue immediately after the Conference did not contain these details.

The references to the FDA were much more muted in connection with several talks by Drs. Rawls and Levy. In spite of the fact that they gave the impression that they would have been successful in selling snake oil off the back of a buckboard wagon in the middle 1800's these men did an effective job of promoting the use of magnetism for a variety of purposes - including the treatment of the human body.

When the writer started reading their books after the conference it appeared that at least 98% of what they said had previously been disclosed in their own books. In spite of this they were worth hearing. Several others who talked on the use of magnetism for diverse purposes such as growing plants, promoting better auto fuel mileage and clearing up mineral deposits in pipes did not measure up to the presentation effectiveness of these men even though there was significant substance to what they disclosed. Although it was not specifically mentioned much of what these others covered has been previously known for some time.

Judging by all that was said and demonstrated at the conference relative to magnetism no one should doubt that this topic deserves continuing serious investigation. There is much current research on this topic which was not mentioned. It is a shame that this was the case and that even the current research discussed was not related to what was already known at the time of the conference. Without a doubt the old topic of magnetism is increasingly being recognized as being vital to life and the world in which we live.

Seldom does a speaker have the ability to actuate my personal "off" switch possessed by Joe Champion. He spoke at the conference on his version of modern alchemy. Seemingly I mentally regurgitated everything of substance contained within his presentation. Perhaps this is a result of his lecture clashing with my time worn degree in chemical engineering. I don't think that this was the case since I delight in new concepts and accept as apparent if not absolute truth nearly every statement which seems to be made in good faith.

My reactions to the presentation of this speaker raise an interesting point. To what extent should the organizer of a conference such as the Tesla Society check out the prospective speakers at the conference? When the conference concerns dubious subject matter an exhaustive evaluation by one who does not believe in the topic of the conference would result in a speakerless conference. While in some cases this might be a blessing it would thwart the dissemination and evaluation of potentially significant information and views. Would Mr. Cham-

panion have given his talk if it was previewed?

The primary "no show" at the Conference was Mark Hendershot - the son of Les Hendershot of Hendershot "coil" fame. To the best of the writer's knowledge no reason for his non appearance was ever announced. Many guessed that this was because he was unable to get one of the Hendershot devices operating. a pricey collection of copies of his father's notes was offered for sale at the conference.

It is easy to reach the conclusion that the Hendershot device does not work from the failure of Mark Hendershot to appear. Don't. The evidence that Hendershot devices did in fact perform is overwhelming. It also makes it clear that an individual who is "tuned" to the device in the sense that Uri Geller relates to an electronic device as he effects its operation is necessary to the start up of a Hendershot unit. Probably Mark Hendershot doesn't have and doesn't know any one having a functioning ability of this type.

Another type of problem concerned another chap - Dennis Lee - who apparently has a record including defrauding individuals by inducing them to invest in operative subject matter. Unfortunately the details of this history were not made clear to those such as this writer who were in the audience at the Conference. In any event, somehow or another, he got on the Conference program.

After a best forgotten talk seeking the support of the audience he announced that he was providing busses at the close of an evening session to take those present to another location away from the Conference where he proposed to demonstrate some of his accomplishments. Those the writer talked to who went on his safari were unhappy about going and seemed strongly undesirably impressed by it.

A further type of complication faced by the Conference organizers concerned an apparently loosely affiliated group who attempted to horn in on and misuse the Conference to promote their purely political views on the US Government and all of the related stuff commonly discussed in connection with various militia and other dissident groups. This minority apparently made little headway.

The majority of those present seemed to disagree with such governmental actions having an effect on the development and disclosure of technical knowledge as have been taken by the FDA and the DOE and seemed to attempt to politely avoid these extremists so as to escape being associated with them. The writer concurred in such escapist conduct so as to avoid unnecessary conflict.

A conference on essentially technical subject matter is not the place to get into unrelated political action. It is grossly improper to subvert and bring unnecessary contention upon a bona fide effort to stimulate questionable technology by associating such technology with purely political beliefs.

Unfortunately at times it is impossible to avoid getting into subjects having political overtones in a meeting such as the ExtraOrdinary Science conference. This is illustrated by speakers at the conference who were armed with valid reasons why both fluoridation of water and dental root canals should be banned. Dr. Huggins was refreshingly effective on the latter topic. Unfortunately both of them conjured up mental images of medieval knights with shining teeth emulating Don Quixote in attacking the world using these reasons as weapons. This is inherently unfair to these

men. Both of them appeared to be well qualified and to be acting in the utmost sincerity.

Seemingly they overlooked one factor - probably nothing is absolutely "safe". Even the FDA recognizes this by approving the use of all sorts of medications as "safe" as required by law with full knowledge that on occasion one or more persons will have adverse reactions to these compositions. If we are required to have an FDA or equivalent, the law governing the activities of such an agency should make it clear that the approval for the use of a specific material or procedure should evaluate both the anticipated benefit and detriment from such use. We should never forget that a coin has two sides.

When all factors are considered, do the detriments from fluoridation and from root canals exceed the benefits? Long ago as a patent lawyer I learned that it was prudent in argument to spend as much time dealing with an opponent's real or anticipated position as was scheduled for directly pushing my client's cause. Hopefully this is a positive suggestion to these speakers.

According to my possibly inaccurate notes, one of the dental speakers indicated that the American Dental Association (ADA) is apparently taking a very interesting position on its "approvals" such as appear on tooth paste and the like. As I understand it someone who believed that such an "approved" product had caused injury or damage named the ADA as a co-defendant in a tort actions. In defending against liability the ADA is believed to have argued that its approval of a product is not a representation that it evaluated the product and considered it okay to market as being safe and effective. This needs to be clarified.

Sonne Ward was one speaker who deserves much more attention than he received. If awards were handed out at the conference for potentially significant new developments he would have received one.

His work on implosion technology was delightfully intriguing. Hopefully it will be made publicly available to a greater extent than could be disclosed in the time allotted at the conference. In the writer's opinion his work holds much promise for the future and must be further investigated. It provides what appears to be a way of getting rid of wastes we do not know how to handle by passing them off on an alternate reality.

The same laudatory remarks made with respect to Mr. Ward's work can be made relative to the disclosure of a Magnetic Resonance Amplifier (MRA) by Joel McClain and Norm Wooten. Although the lectures on this device could be classified as having the aura of old time pitchmanship they gave every impression of being completely on the level and of being well along the road to a material development of virtually unlimited importance. The relationship of their work to _ may help open presently closed minds to a recognition that long forgotten religion and history are applicable to today's developments.

Unless the writer was misled and is mistaken we can all expect to hear a great deal more about their work as time goes on. It was described in the issue of the Tesla Society's magazine which appeared soon after the conference. Their work is disclosed on the Internet at: <http://www.iinet.net.au/~steveb/mra/mraintro.html>

As one might expect lectures such as were given on the MRA device stimulated mental activity - but not always in the expected manner. This is easily illustrated. In mentally reviewing a talk by

John Pickard entitled "Tesla Turbine Research. Tesla's Way!" the writer got a mental image of the discs of a Tesla pump being located on a shaft so as to form an assembly which could be substituted for the paddle wheel of a shallow draft river boat or ship. The use of this type of drive might turn out to be more efficient than the use of paddle wheels or propellers, particularly in situations where weeds are present or there is a significant chance of a propeller being damaged by contacting rocks, logs or the like.

Was this mental image of a Tesla disc drive based on a specific disclosure by Mr. Pickard or was it the product of mental activity resulting from a consideration of a Tesla turbine or pump? While the stimulation leading to a concept such as this is desirable in a situation such as the present it is even more desirable to know who is to be or should be affiliated with the concept.

Much more can be and probably should be stated relative to the Conference. In spite of the fact that the ExtraOrdinary Science Conference was well organized, to many the evening discussions over wine and snacks were probably more educational and stimulating than any of the speakers. These group gatherings should be a permanent part of future conference formats.

The fact that certain of these speakers have not been specifically mentioned in this discussion is not to be taken that their presentations were in some manner or another "impaired". The omission of these unidentified speakers is a reflection of the writer's interests and abilities to effectively comprehend some subject matters better than others. Or it may be an indication that some demonstrated uncommon skill in promoting sleep through the use of hypnosis. ■

BORDERLANDS ONLINE

Borderland Sciences Research Foundation Archives

Connect to Borderlands
on the Internet!

Check out our new home page at:

<http://www.asis.com/bsrf>

Send E-mail to: bsrf@asis.com



TELESCOPES
BINOCULARS &
SCIENCE FUN

(707) 937-3335
P.O. BOX 1010

45050 MAIN STREET
MENDOCINO CA 95460

MUSIC AND NATURAL RESONANCE

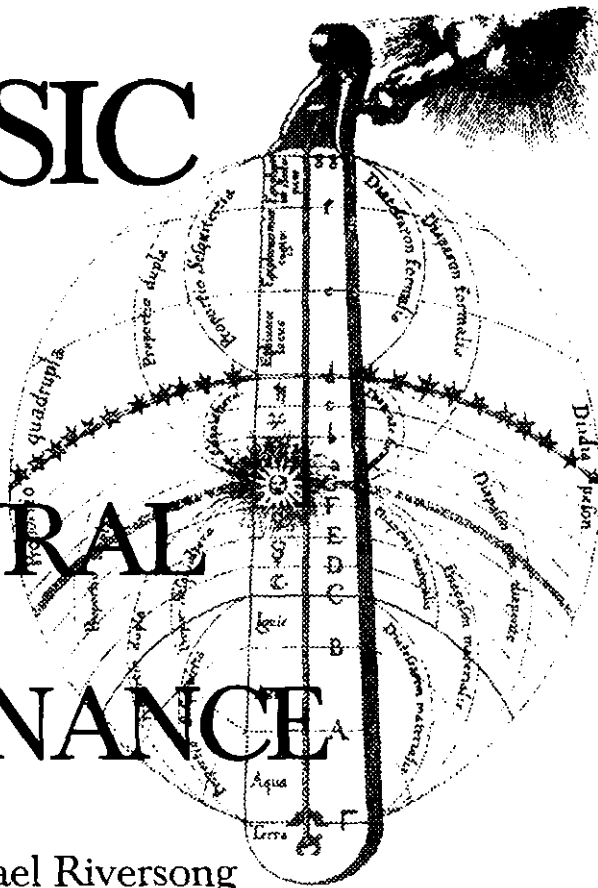

© 1995 by Michael Riversong

MUSIC is a manifestation of resonant principles in Nature. It is an expression of the artist's understanding of natural principles, in all cases. As such, music can create a broad range of effects which express natural laws we are just beginning to understand.

TESTING

Between 1982 and 1985, and inspired by Dr. John Diamond's book, *Your Body Doesn't Lie*, I embarked on a project which resulted in doing an informal kinesthetic arm test on about 200 subjects while listening to music. The test itself is simple, involving putting pressure on the subject's arm as the subject tries to hold it straight out (there are hazards to this test, so doing it indiscriminately is not recommended). Notes were not kept, basically because the results were so uniform, that any departures from the normal were quite memorable. Most of the tests were performed on members of social service clubs and churches around Denver, Colorado, as part of a presentation I worked up which covered how people are affected by music. Early in the project, I prepared a short cassette tape which included examples of several music styles, and took this to all the presentations.

The test tape began with a one-minute section of a Baroque Classical work by Telemann. Then, there was about twenty seconds of "Voodoo Child" by Jimi Hendrix. Neutral selections were represented by a clip of Merle Haggard and some Tamburitzen music from Yugoslavia. Each test began with a pre-test,

checking strength before any music was played.

With only two exceptions, everyone tested strong on the Telemann piece. With one exception, everyone was weak on the Jimi Hendrix piece. The reaction set in within one-tenth of a second. Interestingly enough, many subjects became angry during the Hendrix piece. Everyone was neutral, meaning the same as the pre-test when no music was playing, during the Merle Haggard piece. At the Tamburitzen selection, results were widely variable. No one tested weak, but responses ranged from neutral to extremely strong. After a while, I began to inquire about the ancestry of the test subjects. I noticed there was a slight tendency for people who had some Slavic background to be among those who tested strong on the Tamburitzen music. This was something which I would have loved to pursue further, but a lack of funding precluded continuing the research along those lines.

Exceptions to the general pattern of test results are worthy of note. One person who tested weak on classical music was a close friend, who told me that while in elementary school, he had a very strict teacher who demanded her students go limp whenever classical music was played.

Out of two hundred subjects, one person tested weak on classical music and strong on Jimi Hendrix. He was a "street person" who was attending meetings of an informal science club in Denver. We had a few conversations as a result of this. He told me he was living under a bridge because he was angry at his father, and wanted to prove to everyone what a bad father this man really was. His greatest desire in life, he said, was to be locked up in a library, to study science all the time. He has not been seen in Denver in several years, and I hope he got better eventually.

LIMITATIONS

Music which is limited in scope, as in some of the harsh albums available today in most of the urbanized portions of this planet, shows a non-existent understanding of natural principles. The lowest understanding of nature can be seen in acts of criminal mischief, drug use, and revenge. Music which revolves around these activities is harsh, grating, and has only a limited sphere of tools available within its repertoire. In our present society, this description applies to Death Metal, Rap, and some Reggae Dub music. When tested on most people, music of this type will usually weaken them. The only people who may test strong on these kinds of music are generally those who are completely alienated from society and from good health.

Most music is somewhat neutral in character. It does not create any measurable physical effect on most listeners. Lyrics which accompany the music generally serve to reinforce social patterns



and reactive (or unconscious) mind scripts. The more people who share a particular script, the more popular the song tends to become. Sometimes this works the other way around, and an especially compelling song becomes popular enough to actually change the scripts of a lot of people. An noteworthy example of this is might be "Love One Another" by Jesse Colin Young, released in 1966.

Besides lyrical content, three characteristics of music work together to create effects on people. By carefully observing the balance of these characteristics in any piece of music, it is possible to determine for yourself what effect it will tend to have. This method of analysis can replace the kinesthetic arm test.

TONALITY

Tonality is the first characteristic. We can assume, for purposes of this discussion, that our physical evolution as a species is a crude parallel to spiritual evolution. This is a teaching of many spiritual traditions. If so, it follows that tones which emulate natural phenomena should feel somewhat comforting to us. This is one of the reasons why classical music tends to impart strength. All of its instruments can be traced back to natural Earthly sounds. Woodwinds emulate wind blowing through reeds. Percussion emulates things falling on wood or membranes. Stringed instruments, such as violins and harps, emulate sounds of plants held taut. Brass

instruments constitute the most radical departure from natural sounds ordinarily found in classical music, but they can be traced to mineral phenomena and wind in caves.

Now, there are also some synthesized sounds which create good effects. Our explorations in space have shown that all celestial bodies emanate sounds. Many which were recorded by NASA have been cataloged and released to the public by Dr. Jeffrey Thompson. The sounds from nearby planets, as picked up by transducers aboard space probes, are similar to sounds generated by synthesizers which are known to be healthy.

Many of these sounds resemble Tibetan bowl bells, which are made of special alloys according to ancient traditions. Another good type of sound is one which has precisely calibrated interval harmonics in thirds, fifths, or sixths. This also can be heard on some of the planetary sound recordings.

Harsh tones in music often come from an attempt to integrate obnoxious acoustical products of technology. Several classical composers even tried to do this in a formal manner, with varying degrees of success. Hoenneker once composed a piece which exemplified train sounds. Varese would use sirens as a recurring motif. And John Cage actually built whole compositions around random noise. The fact that many readers have probably never heard the works of these composers speaks for itself. Now, "heavy metal" has come along, which completely integrates harsh technological noise into its fabric. This form of music was actually invented in 1932 by Antonin Artaud, while he was in an insane asylum. At the time, he called it "Theater of Cruelty", which aptly describes the nature of much of this work. For many of the most popular acts, theatrical trappings actually overshadow the music itself.

RHYTHM

Rhythm is extremely important. Dr. Diamond had found that one particular rhythm, found predominantly in "hard rock" music of that time (1975) would always produce a negative effect, even when simply tapped out by itself without other instruments. This rhythm is counted "one-and-TWO pause". It is literally the reverse of the human heartbeat. Think of getting on a carnival ride. Your body is subjected to strange motions and sensations, which are disconcerting but interesting. A few minutes later, it's over. Now imagine getting on that ride, and the operator walks away, leaving you trapped on the ride. A long time later, you're going to be in pretty bad shape. That's the effect generated by this negative rhythm.

Rhythmic patterns have been extensively cataloged and worked out by members of the Yoruba culture of Nigeria. Many other African groups have similar systems, of varying degrees of complexity. In many cultures of that region, rhythm is in itself a spiritual teaching. Natural forces, known generally as Loas, are said to completely take over people who dance intensively to certain rhythms. It is a common practice among many Africans (and some inhabitants of Haiti and Brazil) to take on the character of Loas during rituals. Within the context of these cultures, this has a great therapeutic value. In other cultures, mild variants of these rhythms can be useful to generate effects. Further research on this subject is in progress.

MELODIC SEQUENCE

The most technical point of music is the actual melodic sequencing. This is always specific to a culture, and can be seen as a defining point which differentiates one culture from another. The dominance of a certain melodic scheme when transferred from one culture to another can often indicate the extent to which a culture has come to dominate another.

In India, the most highly refined set of tonal sequences on this planet has been developed, called "ragas". This system contains over 80,000 possibilities, many of them precisely classified as to emotion, time of day, and season. As you can imagine, tonal sequencing is an extremely technical study. The possibilities for application to the fields of medicine, architecture, and spirituality are vast.

Western music, which we are probably more acquainted with, is based on a system developed by Pythagoras. In this tightly structured system, eight tones make up a scale from one harmonic point to another, called an octave. Each tone is the starting point for seven possible sequences of intervals between the tones. Later, twelve tones between an octave were set up, but the basic scheme remains the same. Each tone can have a certain characteristic, and each sequence of tones can create a harmonic manifestation in the listener which can enhance a particular characteristic of life. By using this system consistently in concerts and on tapes over a number of years, the expression of these characteristics has been observed.

There is no ethical way to do any research which completely isolates one characteristic tonal sequence from all others and force it on a listener. Therefore, the observations are informal, and always subject to modification. When in a concert situation, the audience is always the primary consideration, and their responses to each piece of music are carefully observed in order to determine the best sequence to use at any time.

BRIDGE BETWEEN THE UNIVERSES

When considering the effects of music, science and spirituality inevitably meet. Whether this becomes an alliance or a collision depends strictly on the viewpoint of the observer.

Completely secularized science has certainly not had a good record for itself, having brought our species to the brink of total destruction through toxic waste, radioactivity, and genetic experimentation. Therefore combining the two needs to be tried before we get ourselves into an even worse situation on this planet. One good point about spirituality is that many traditions, having come from extremely diverse origin points, have major points of agreement. For the remainder of this paper, only these points of agreement which transcend a number of traditions will be considered. We are looking at a commonality of practical characteristics, rather than trying to quote specific scriptural passages to prove a point.

Most spiritual teachings agree there is a material universe and a spiritual universe. The two operate by completely different sets of laws. In the material universe, laws have been observed and to some extent codified as science. These involve the existence of natural forces, matter, space, and time, and the interplay between these. Operations in the spiritual universe center more around the simultaneous individuality and unity of all spirits. Laws which

apply in the material universe are only relevant if a member of the spiritual universe has decided to agree with these laws. Many spirits have, and are now embodied as humans, living strictly by the laws of material manifestations. Some spirits in human form move back towards the spiritual universe through study, practice, and devotion. Music can facilitate this process, and has been used for this purpose everywhere in the world.

Many teachings say that an archetype is created in the spiritual universe, which then can manifest in the material universe, according to agreed-upon laws. Music is said to be the most directly accessible archetype. This is true because resonance is actually a force of nature in itself. Resonance means that one thing, tuned to another, can vibrate in sympathy across a distance. This is an observed phenomenon in the material universe.

Resonance operates in the spiritual universe as well. No other natural force from the material universe seems to operate in the spiritual realms. In fact, most traditions which have addressed this problem at all agree that forces such as gravity, electromagnetism, and conservation of energy specifically do not apply to the spiritual universe. It has often been said in certain scriptures that even time itself means nothing in the spiritual universe. Thus resonance is the only force which most agree operates simultaneously in both universes (it may be possible for electromagnetism to create a resonant force in the spiritual universe. If so, this is an extremely dangerous operation and should not be supported).

Two souls in resonance with each other will always manage to arrange a meeting, in spite of any material circumstances. Many spiritual traditions on this planet are dedicated to the process of creating a resonance between the souls who are participating, and the ultimate Source of the whole Universe. Music is almost always a part of these traditions. Harmonious music will invoke vibrations in living bodies, which then are transmitted into the spiritual nature of the bodies. So music is actually an interface between the spiritual and material universes. This is why it has such profound effects on people. Music also becomes a doorway through which we can learn to create direct effects on the material universe through the medium of sound. This process is called Harmonic Chemistry, which is covered in another work.

REFERENCES:

Dr. Jeffrey Thompson, *NASA Space Recordings*, 204 N. El Camino Real #E116, Encinitas, CA 92024.

Halpern, Steven, *Sound Health*.

Joachim-Ernst Berendt, *Nada Brahma - The World Is Sound*, Destiny Books, 1987.

Kay Gardner, *Sounding the Inner Landscape - Music as Medicine*, Caduceus, 1990.

MICHAEL RIVERSONG has a degree in Chinese language from the University of Colorado, and is a recognized expert on the design art of Feng Shui. He has been a musician since childhood. Since 1984, he has recorded over 13 albums of his original music on harp, flute, guitar, and other instruments. He is the author of *Design Ecology* (available from BSRF), a compendium of information and techniques for dealing with environmental situations. Michael currently travels extensively, performing, writing, and providing design consulting services.

Did you miss something?

BORDERLANDS originated as Meade Layne's **Round Robin** in 1945 and was changed to **The Journal of Borderland Research** in 1959, finally becoming **BORDERLANDS** in 1992. **BORDERLANDS** backissues are available from 1990 to the present with very limited quantities of early original issues. Single issues are \$6.95.

☐ THE JOURNAL OF BORDERLAND RESEARCH

Vol. 46, Nos. 3 & 4, May-June-July-August 1990 (56 pp.)

- * THE IRON ROD OF MARS - Alison Davidson
- * HOMEOPATHY: A Vibrational Perspective - Dr. Donald R. Beans
- * LIFE FORCES AND PHYSICS - Buryl Payne, Ph.D.
- * EDGAR CAYCE & THE RADIAL ACTIVE APPLIANCE - Phil Thomas
- * BIOCIRCUITS: New Technologies In Holistic Health - Terry Patten
- * OZONE IS GOOD AND NATURAL - Ed McCabe
- * RADIONIC MACHINERY TO REGULATE EARTH VEINICS - Gerry Vassilatos
- * NOXIOUS EARTH ENERGIES - Kathe Bachler
- * EFFECTS OF 6-10 Hz ELF ON BRAIN WAVES - David S. Walonick
- * PHYSICS AND TECHNOLOGY OF THE PHENOMENON OF SPACE POWER GENERATION - Paramahansa Tewari

☐ THE JOURNAL OF BORDERLAND RESEARCH

Vol. 46, No. 5, Sept.-October 1990 (32 pp.)

- * THERE IS NO "FREE" ENERGY - An Anonymus Friend
- * MAGNETIC ENERGY TAUGHT ME BASIC NEW CONCEPTS - Larry Spring
- * THE COIL/ORAC EFFECT - Nicholas A. Reiter
- * VIKTOR SCHAUBERGER'S BIOLOGICAL SUBMARINE - Albert Zock
- * UNDERSTANDING THE CONTINUOUS UNIVERSE, preparing for transmutation - Rhetta Jacobson Baumgartner
- * AMERICA'S AMAZING ALCHEMIST - Vincent H. Gaddis
- * QUICKSILVER - MERCURY'S LIQUID METAL - Alison Davidson
- * OMENS, SIGNS AND THE ENERGIES OF TIME - Eugenia Macer-Story
- * CONDUCTING CHLOROPHYLL ENERGY OVER WIRES - Dr. T. Galen Hieronymus

☐ THE JOURNAL OF BORDERLAND RESEARCH

Vol. 46, No. 6, Nov.-December 1990 (32 pp.)

- * JUPITER AND TIN - Alison Davidson
- * JACK DERBY - MR. FIX-IT/NEW AGE INVENTOR - Harry Davis
- * APPARATUS FOR DETECTING EMANATIONS FROM PLANETS - Buryl Payne
- * MAGNETIC ENERGY TAUGHT ME NEW BASIC CONCEPTS, Part II - Larry Spring
- * PHANTOM ARMIES OUT OF TIME - Vincent H. Gaddis

☐ THE JOURNAL OF BORDERLAND RESEARCH

Vol. 47, No. 3, March-April 1991 (32 pp.)

- * OPERATION CLINCHER - A B.R.S.F. Special Report
- * SACRAMENTAL THINKING - Joel A. Wendt
- * URANUS AND THE RADIOACTIVE METALS - Alison Davidson
- * THE WORLD RUNS ON AC - Larry Spring
- * THE SPIRAL COIL MULTI-WAVE OSCILLATOR, Part II - Louis A. Schad

☐ THE JOURNAL OF BORDERLAND RESEARCH

Vol. 48, No. 3, May-June 1992 (32 pp.)

- * BORDERLAND QUAKES! - Michael Theroux
- * ON THE TRAIL OF THE LAKHOVSKY M.W.O. - Jorge Resines
- * VIEW FROM THE BORDERLANDS: Some MWO/RCO Questions Answered - Tom Brown
- * M.W.O. ROUNDUP - Peter A. Lindemann
- * EXISTENCE OF ABSOLUTE TIME - Dorotheos C.E. Cody
- * FIZIX CORNER - Peter A. Lindemann
- * A ROUND PEG IN A SQUARE HOLE - Larry Spring
- * FIELD GENERATORS - R.F. Directo
- * SCIENCE FICTION REVIEWED - Michael Theroux

☐ THE JOURNAL OF BORDERLAND RESEARCH

Vol. 48, No. 5, Sept.-October 1992 (32 pp.)

- * TUNNELS OF THE TITANS - Vincent Gaddis
- * PRE-COLOMBIAN GEODESICS - Jorge Resines
- * ANCIENT COSMOGRAPHY AND THE CROP CIRCLES - Michael Theroux
- * THE CIRCLEMAKERS - Book Review
- * MUSIC, ALCHEMY, AND PROJECTIVE GEOMETRY - Michael Theroux
- * DESIGN ECOLOGY - Michael Riversong
- * FIZIX KORNER - Peter Lindemann
- * AIDS/SYPHILIS UPDATE - Peter Lindemann with Joan McKenna
- * THE UNION ESPIRITISTA CHRISTIANA DE FILIPINAS - Harvey Martin

☐ THE JOURNAL OF BORDERLAND RESEARCH

Vol. 48, No. 6, Nov.-December 1992 (32 pp.)

- * CHACO CANYON - Great Wonder of the World - Alison Davidson & Tom Brown
- * RECORDING TELLURIC SIGNALS, Part I - Gerry Vassilatos
- * ASTRONOMICAL CORRELATIONS FOUND IN CROP FORMATIONS - Colette M. Dowell, N.D.
- * FIZIX KORNER - Peter Lindemann

☐ BORDERLANDS - The Crossroads of Science and Spirit

Vol. 49, No. 1, 1st Quarter 1993 (52 pp.)

- * THAT WHICH IS ETERNAL IN US MUST BE AWAKENED - Tom Brown
- * DEVELOPING THE KOLISKO APPROACH - Nick Kollerstrom
- * I AM ENERGY - Larry Spring
- * A POSSIBLE ALTERNATIVE TO BATTERY POWERED VEHICLES - Ed O'Brian
- * DESIGN ECOLOGY, Part II - Michael Riversong
- * RECORDING TELLURIC SIGNALS, Part II - Gerry Vassilatos
- * THE PAPER DOCTOR - Book Review by Peter A. Lindemann
- * THE LAKHOVSKY MWO: BACK TO SQUARE ONE - Peter A. Lindemann

BORDERLANDS - *The Crossroads of Science and Spirit*

Vol. 49, No. 2, 2nd Quarter 1993 (52 pp.)

- * THE MYSTERY OF QIGONG - Dr. G.K. Knowlton
- * CHAOS, ORDER OR NATURE? - Michael Theroux
- * SCHAUBERGER VS. ARCHIMEDES - Albert Zock
- * INTERACTION OF MAGNETIC FIELD AND POWER CURRENT IN SPACE POWER GENERATION - Paramahansa Tewari
- * FIZIX KORNER - Peter A. Lindemann
- * ELECTRO-THERAPEUTIC APPLIANCE - U.S. Patent 412,196, John S. Mellon
- * Paradigm de Jour GREY ALIENS BITE THE DUST - Alison Davidson
- * DESIGN ECOLOGY, Part III - Michael Riversong
- * SCIENCE & HEALTH and THE EARTH & OURSELVES: Books by Georges Lakhovsky - Reviewed by Jorge Resines
- * ANOTHER POSSIBLE ALTERNATIVE TO BATTERY POWERED VEHICLES - Ed O'Brian
- * EXPLORATIONS IN GRAND CANYON: Mysteries of Immense Rich Cavern Being Brought to Light - "Phoenix Gazette", April 5, 1909

BORDERLANDS - *The Crossroads of Science and Spirit*

Vol. 50, No. 2, 2nd Quarter 1994 (52 pp.) *Riley Hansard Crabb Memorial Issue*

- * SHED NO TEARS FOR RILEY - Trevor James Constable
- * FLYING SAUCERS AND AMERICA'S DESTINY - Riley Crabb
- * THE MEANING OF THE WORD PSYCOGRAPH - E. D. O'Brian
- * DECIPHERING THE MOST MYSTERIOUS MANUSCRIPT IN THE WORLD - Michal Theroux
- * EIDETIC GEOCENTRISM - Part I - Gerry Vassilatos

BORDERLANDS - *The Crossroads of Science and Spirit*

Vol. 50, No. 3, 3rd Quarter 1994 (52 pp.)

- * TZOLKIN - John Major Jenkins
- * THERMODYNAMICS AND FREE ENERGY - Peter Lindemann
- * COMMUNICATION AND THE HIDO-DENDRITIC EXPERIENCE - Michael Theroux
- * INDUCING THE URPLANZE - Dennis Klocek
- * EIDETIC GEOCENTRISM - Part II - Gerry Vassilatos
- * EARTH'S CENTER OF GRAVITY - UP OR DOWN - Ray Palmer

BORDERLANDS - *The Crossroads of Science and Spirit*

Vol. 50, No. 4, 4th Quarter 1994 (52 pp.)

- * THE FIFTH SUN - Aymon de Roussy de Sales
- * SEISMOLOGY IN BRIHAT SAMHITA - Dr. E. A. V. Prasad
- * THE ETHER-WORLD OF THE PLANETARY SPHERES - Dr. Guenther Wachsmuth
- * EIDETIC GEOCENTRISM - Part III - Gerry Vassilatos
- * KONG JING - EMPTY FORCE - Dr. G. K. Knowlton
- * FOLLOW THE SUN - Larry Spring

BORDERLANDS

The Quarterly Journal of Borderland Research

Vol.51, No.1, 1st Quarter 1995

- * UNKNOWN ITALY - Jorge Resines
- * THE MARS REDHEAD LINK II - MARS DISTRIBUTION PATTERNS IN REDHEAD POPULATIONS - Judith A. Hill
- * SCORPIONIC AMERICA - David Solte
- * THE NATURE OF THE ETHERIC WORLDS - N. Meade Layne
- * THE ALCHEMY OF CAPACITANCE - Dennis Klocek
- * EIDETIC SPACE - THE GROUND OF BEING - Gerry Vassilatos
- * ON THE DISSIPATION OF THE ELECTRICAL ENERGY OF THE HERTZ RESONATOR - Nikola Tesla
- * FIZIX KORNER - Peter Lindemann

BORDERLANDS

The Quarterly Journal of Borderland Research

Vol.51, No.2, 2nd Quarter 1995

- * THE FARNSWORTH FUSOR: THE MOST NOTABLY FORGOTTEN EPISODE IN "HOT" FUSION HISTORY - Gerry Vassilatos
- * BARCODES: "MARK OF THE BEAST" - Peter Lindemann with Ajna Luminaria
- * THE MARS REDHEAD LINK II - MARS DISTRIBUTION PATTERNS IN REDHEAD POPULATIONS, PART II - Judith A. Hill
- * UFO MIND GAMES - Eugenia Macer-Story
- * REVERSING THE AGING PROCESS - Dr. G.K. Knowlton
- * ON PROPHETS AND PROPHECIES - Jorge Resines
- * THE GEOLOGICAL COLUMN - Thomas J. Brown

BORDERLANDS

The Quarterly Journal of Borderland Research

Vol.51, No.3, 3rd Quarter 1995

- * TESLA'S "SELF-ACTING" ENGINE - Peter Lindemann
- * EARTH ENERGY AND VOCAL RADIO: NATHAN STUBBLEFIELD - Gerry Vassilatos
- * MYSTERY STONE OF NEW MEXICO - William Peavy, Ph.D.
- * EARTHQUAKES AND ASTROROLOGY: THE REGIONAL FACTOR IN PLANETARY SEISMIC CORRELATION - Judith Hill
- * THE REDISCOVERY OF VRIL: AN INTERVIEW WITH GERRY VASSILATOS - Conducted by Michael Theroux
- * AQUALITHIA REVISITED - Haroldine
- * IMPROVING SEX THROUGH QI GONG - Dr. G.K. Knowlton

Not all backissue titles are listed here.

Most titles back to 1990 are available.

Please order the Borderlands Table of Contents for a complete listing of backissues from 1945 to present (\$6.95 + p&h).

All titles subject to availability.

Order any 10 issues and receive 25% off!

All prices subject to change without notice.

To order call (707) 825-7733 or write:

Borderland Sciences Research Foundation

P.O. Box 220 ★ Bayside ★ California ★ 95524 U.S.A.

<http://www.asis.com>

The **Ray-X Button**™

Inexpensive relief from computer related fatigue

From **VrilTek**

Computer "strain" or "fatigue" is a familiar experience for those who work with computers on a daily basis. While experts seek the true cause of these fatigue related sensations, few of the highly priced systems actually afford any reasonable relief.

Several recent discoveries have provided a simple and cost effective means for eliminating the fatigue syndromes associated with exposure to computer monitors. These discoveries have led to the development of the **Ray-X Button**™. The **Ray-X Button**™ is based in part on the researches of Georges Lakhovsky, inventor of the Multiple-Wave Oscillator. It is constructed with a proprietary material which attracts, absorbs, and transforms monitor related emissions, rendering them harmless to living systems. The **Ray-X Button**™ produces results you can actually FEEL. The **Ray-X Button**™ is THE cost effective way to eliminate monitor or television related fatigue.

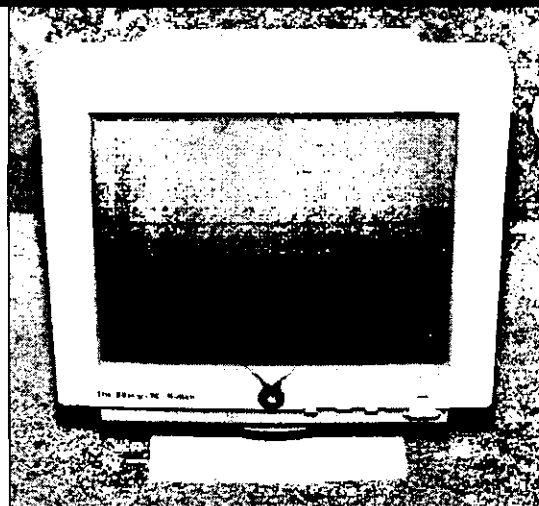

Read what satisfied users say:

My husband bought a Ray-X Button for my computer 2 months ago. I was skeptical about the benefits but put it on my monitor anyway. Then, just in the past two weeks I realized that I have been working up to six hours a day at my computer. Before the "button", I could only manage a couple of hours before burning out. I'm convinced the noticeable effects are from the Ray-X Button.

— N. Simpson, Houston, Texas

Computers have always made me feel sick. Three hours use resulted in 3 days of "jet lag" and horrible eye strain, despite my glare screen. Since installing my Ray-X Button, I have no more fatigue and no more eye strain — in fact I have more energy!

— Judith Hill, Portland, Oregon

The **Ray-X Button™ Available from Borderland Sciences Only \$19.95**

Please include \$3 for postage & handling



P.O. Box 220 ★ Bayside ★ California ★ U.S.A.
Postal Zone 95524

ADDRESS CORRECTION REQUESTED

BULK RATE
USA POSTAGE
PAID
Providence,
Rhode Island
Permit No. 2475