

CANADIAN
UFO REPORT
F
O

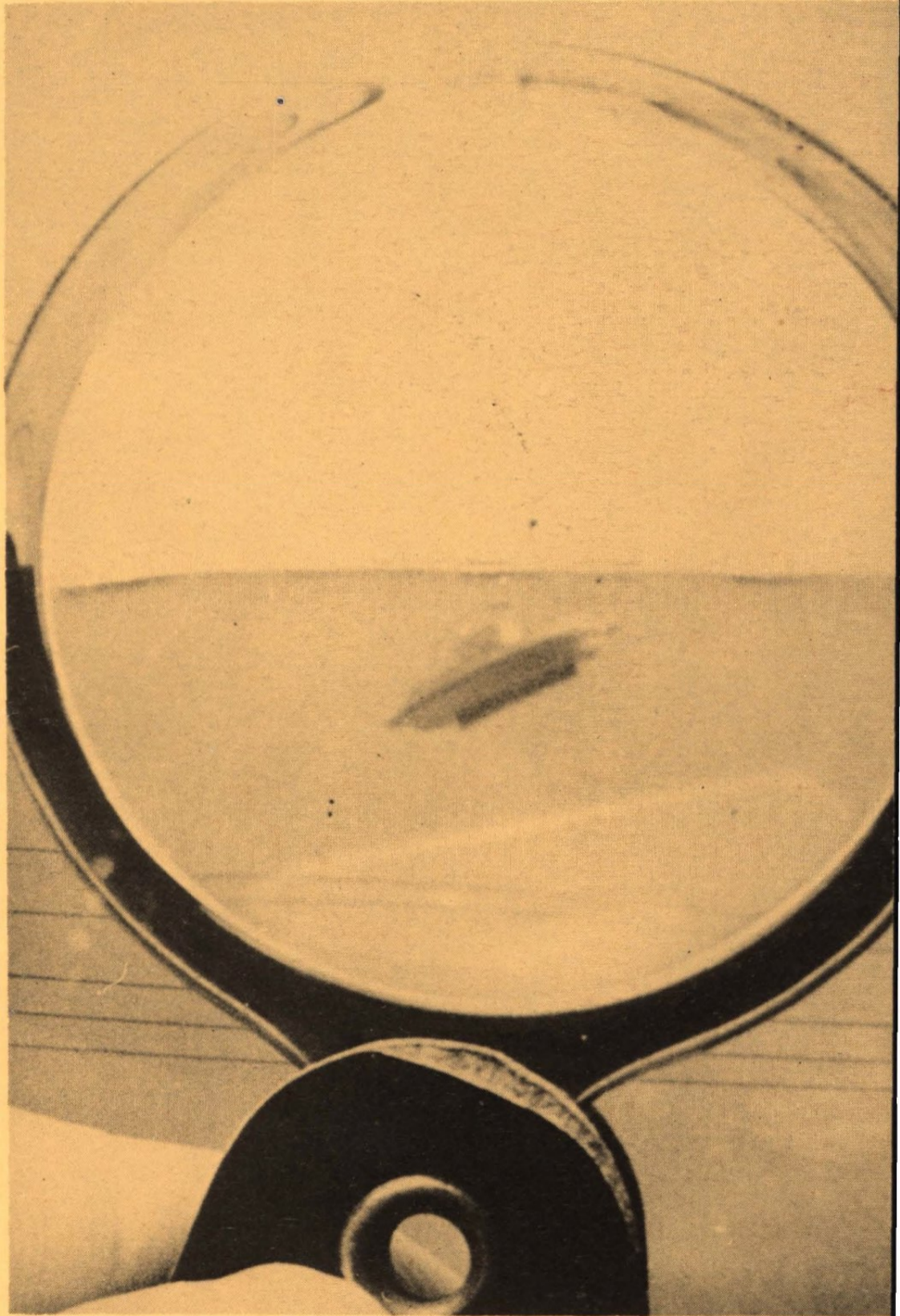

**A STUDY OF FLYING SAUCERS
&
OTHER AERIAL PHENOMENA**



This May Be The Best UFO

Photo Ever Taken

(SEE COVER STORY)

**CANADIAN
UFO REPORT
Vol. 2, No. 4
(Whole No. 12)**

Price: \$1.00

**CANADIAN
UFO REPORT**
Vol. 2, No. 4
(Whole No. 12)

*(Second class mail - registration
no. 2564. Return to Box 758,
Duncan, B.C. if undelivered.
Postage guaranteed.)*



CONTENTS

"Flying" Cars	1
Roadside Visitors	5
Badland Rovers	7
"Planets" at Large	9
That Well-Made Look	11
Cover Story	12
Nothing in Press?	14
From Dr. McDonald's Files	16
Flying Blocks of Ice	25
Camera Clues	26
For Your Bookshelf	27
Letters	30
Meetings	35
Announcements	36

EDITOR & PUBLISHER:
John Magor

CONTRIBUTING EDITOR:
Brian Cannon

U.S. CONTRIBUTING EDITOR:
Hayden Hewes

PHOTO ANALYST:
Richard Horsfield

ARTISTS:
Lesley Footner
Hal Crawford

ADVERTISING & CIRCULATION MANAGER:
D.H. Potts

FIELD AGENT:
Daniel Radford

Address all correspondence to:
Canadian UFO Report,
Box 758, Duncan, B.C. Canada

©J.F. Magor, 1971

Material from this publication may be reprinted
without written permission provided credit is
given at head of article to Canadian UFO
Report.

Printed by Rapier Press Ltd.

COMMUNICATION? YES!

Perhaps because the names Magyar and Magor stem from the same tribal origin, this line in Erich von Daniken's book 'Return to the Stars' (see For Your Bookshelf) caught our attention:

"When the ancient Magyars buried a dead man, they said farewell to him with the words: 'He will disappear into the constellation of the Great Bear.' "

Von Daniken's point here was to develop his — and others' — theme that in ages beyond record Earth was colonized by travellers from other worlds and that ancient man knew them as his ancestors. While that by itself is a subject of enormous interest, reference to the Great Bear reminded us of an interview in our first issue that touched on a separate, often asked question: Why don't they communicate with us?

In that early interview young Marina McReedy, living in the Yukon, said one night she and other children saw a strange star in the middle of the Big Dipper (or Great Bear). The light disappeared, only to return to the same position before finally blinking out.

In later interviews there were other, though less striking, references to night-light movements around the Big Dipper and other familiar star patterns until we wondered if those maneuvers were an intended means of UFO communication. Knowing the star formations we look at most often, had our visitors chosen this safely remote way to establish contact? Going a bit further, were they actually showing us where they were from?

Now, in Dr. Hynek's newly published book 'UFO Experience' (also see For Your Bookshelf) we are given another strong hint that the UFOs are sending us visual signals — again, significantly, with Ursa Major as the setting. This case involved two competent observers who noticed two "stars" in the Big Dipper revolving about each other like lights on a pinwheel. Finally stopping in a "roughly north-south orientation," they moved away from each other until the one going south halted as the other continued on its way.

If we were trying to show our place in the sky to an uninformed alien world, we would do exactly the same thing — first the elaborate eye-catching movement, then the pointer. There are many other cases on record of nocturnal lights acting in strange concert as if determined to be noticed, so now the question is how long has this been going on without anyone paying attention?

In the case cited by Dr. Hynek no follow-up was made despite efforts in that direction — and, sadly, even among those of us concerned with the UFO puzzle, "night lights" rate low on the interest scale. This is the category where pranksters proliferate, where witnesses end up chasing Venus and where the objects themselves rarely contain any significant detail.

But it may be precisely this category that holds the main clues to the UFO mystery.

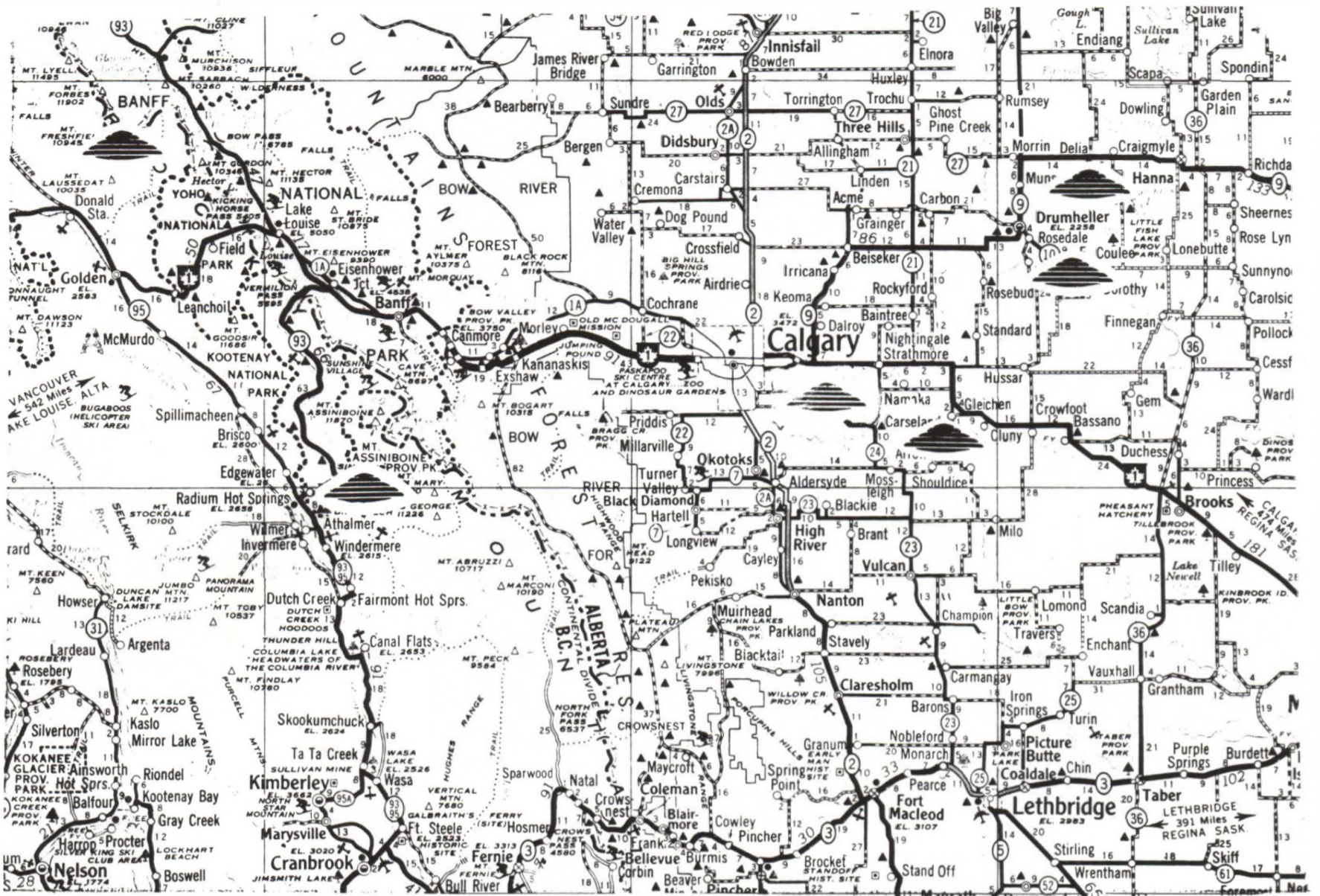

UFO PLAYGROUND



STRANGE CASE OF "FLYING CARS"

(Information on the following two cases was taken from recorded interviews kindly made available to us by W.K. Allan of Calgary who until recently conducted a radio series on the UFO question. Allan also provided tapes on the occupant sighting in Rosedale and the Joe Klimek incident, both also reported here, which we supplemented with our own inquiry. We are indebted to him for his help.)

Perhaps because it is one of their favorite convention centers, flying saucer operators in western Alberta are given to sportive antics. True, mischief is part of the ufoccupant character, but in this particular area their sense of fun is sometimes so boisterous it scares victims out of their wits. Ask Wilton Raw Eater and his wife, Rosalin, of the Blackfoot Indian Reserve near Gleichen.

The date was May 14, 1971.

"I went to the bar and had a few beers," Raw Eater said, "and then we started coming home. It was at night. Then just up the hill we passed a few houses and all of a sudden see this bright light. It hit us just like lightning, on the right side of the car (a 1962 Pontiac Tudor). We went on a little way and I didn't notice anything for a few seconds until the wife told me 'The car's off the ground.'

"Well, I kept steering the car while we stayed on the side of the road. It didn't bother me. We went for about a quarter of a mile. I had the lights on. Then all of a sudden the car hit the ground. I could feel the wheels when they hit. Then we drove home right away and went to my brother's place. We told his wife about it and waited for my brother and told him about it."

Explaining points raised by Allan, Raw Eater said he did not really steer the car during this strange flight. He just held the wheel and the car stayed over the road. After his wife spoke, he could see through his wide window they were in the air. Meanwhile, he said, the speedometer showed 40-45 mph.

One might decide the whole experience could

be traced to Raw Eater's "few beers." His calm feeling as he floated along could suggest just a pleasant alcoholic mood. But to his wife it was nothing of the sort.

"At first I didn't really care," she said. "I thought it was just the speed, because he always speeds. But then I noticed it because we have rough roads and can feel the bumps. This was just like driving in a new car and our car isn't that new. But then I looked down and our car was off the ground."

Mrs. Raw Eater told Allan she thought the car was about two feet in the air. She didn't remember how long it lasted because she was "too scared." Then she felt a bump and knew they were back on the road.

"You can always tell when you're on the roads we've got. They're real bad."

The strange light went off "just like that" when they landed, she recalled.

"Then I told him to drive a little faster because I wanted to get home to my kids. I thought that was the last time I was going to see them. It really scared me, so we took the kids in the car and I told him 'Let's go over to your brother's.' That's when we went over to his brother's place."

Mrs. Raw Eater's remark about being "scared" was an understatement. She was so terrified by what happened that for two weeks she refused to go out in the car.

If the notion persists that those beers are still the answer, consider the case of Mrs. Barbara Smythe, a schoolteacher at Craigmyle, just 50 miles northeast of the Blackfoot Reserve. The date was Feb. 18, 1969.

Driving to school that morning, which she described as "beautiful," Mrs. Smythe saw something above a hill to the right she couldn't believe. It was a "gigantic, bright, bright pinky-red thing with two layers" which was three times the size of a granary of 14-foot diameter. The object was revolving. It contained two huge flashing white lights and was surmounted by something "like a tent with flames on top" and sides "going in and out."



Photo by Yvonne Allan

Mr. & Mrs. Wilton Raw Eater

After driving a few hundred yards, the young school teacher noticed the object had jumped abruptly to another hill and simultaneously her car was floating along at about 20 mph, after she had shifted it into high gear at 30.

"I didn't seem to be steering it," she told Allan, "or hit any bumps. And there was no noise, nothing . . . the car just seemed to keep on going down the road. I didn't seem to be able to get my foot off the gas and put it on the brake.

". . . I kept thinking, what if I meet somebody? But I didn't meet anybody. The car was floating along OK, so I looked back at the thing, I was so hypnotized by it. But as for the rest of my body, I'm sure it didn't move. When you're driving, your hands move a little bit, but mine didn't. I just sat like that."

To establish that the silence around her was "unnatural" which would help confirm the floating sensation, Allan asked Mrs. Smythe if she usually heard the sound of the car.

"Oh, sure," she replied, "I hear the bumps, because it's bumpy out there. I steer through bits of ice and ruts and stuff. I just kept my hands in the same place and the car just seemed to float along on the ground. It was horrible!"

Allan then asked how many times she looked at the object.

"Well, I was more or less staring at it all the time. Maybe three minutes, but I wouldn't bet on it."

After she had floated along to the end of a one-mile stretch of road, she saw the flashing object disappear behind the hill. Although she

did not explicitly say so, presumably at that moment her weird experience ended. In any case, she continued on to school, driving normally.

An incidental note of the interview was that at school Mrs. Smythe had declared herself a non-believer in flying saucers. This came about a short time before when some of her pupils said their mothers had seen them.

"Oh, it's impossible," she told them. "There is no such thing. It's just imagination. Then they argued with me, 'but my mother saw it,' I said 'I don't care. There is no such thing.'"

"But now I've seen one!" she exclaimed.

Note that Mrs. Smythe mentioned being "hypnotized" by the object. Evidently she meant this in the sense of having her attention held by it, but in both these cases there is a strong clue that all three subjects were truly hypnotized, and the clue is: none of them said a word about hearing the roar of their racing motors. If the cars were really free-wheeling in the air, the engine noise would have been overwhelming, just as it is when the accelerator is applied in neutral gear. (Mrs. Smythe insisted she could not get her foot off the gas, yet she heard absolutely nothing; and Raw Eater said his speed continued to show 40-45 mph - an unlikely observation, by the way, if he were really in the air since a speedometer is governed by wheel-action on the road - yet he and his wife too heard nothing.)

So we are faced with another possibility: instead of physically launching the two cars in flight, the UFOs enveloped the three subjects in a mood where everything seemed smooth and easy. In other words, the cars were not in the air but conditions of flight were simulated. We think this is the more likely explanation.

A contradiction, of course, is the fact that Mrs. Raw Eater said she looked down and saw they were two feet off the ground. But remember, her first impression was that the bumps had gone. Consequently she had a sensation of flying even before she looked. Then peering down in the darkness and perhaps dimly seeing the gravel road flowing past, she decided for sure they were in the air . . . as her husband did, too, when she told him about it. Emerging from their trance and feeling the bumps again, and hearing the usual noises, they might readily have thought they had landed back on the road.

As for Mrs. Smythe, she never did say her car was in the air. Instead, it "just seemed to float along on the ground." Being in bright daylight and fully alert, she was in a better position to

see what was really happening than the other two.

Note that both drivers kept their hands on the wheel and thus could maintain control, even though subconsciously. Remember also that creating a sense of well-being is part of the UFO bag of tricks. Perhaps the unseen operators of these two flying saucers thought they were giving their subjects a pleasant thrill, though in fact they were giving two women a very bad scare. (With Raw Eater they had more success. Obviously he enjoyed the unexpected ride.)

All that seems to be a fairly pat answer, but in ufology there is no such thing. After all, there are instances of car levitation, in some cases involving an instantaneous change of position over hundreds of miles.

And that's more than can be said for little guessing games like this which usually end up where they started.

HIGHWAY SNOOP

Although it simplifies things to label the Rocky Mountain foothills as UFO country and have it account for flying-saucer activity for hundreds of miles around, this broad assumption may not be justified. In fact, Mrs. Smythe and the Raw Eaters may not have been in the domain of the foothills crowd at all but at the entrance to another nest of activity which apparently exists for a very special reason . . . to explore the Drumheller "badlands."

An incident along the highway into Drumheller one summer evening in 1967 deserves mention here because it seemed almost to mark the boundary of that nest.

A principal witness was Mrs. Ruth Pears, then of Calgary and now living at Radium Hot Springs, B.C. where her husband is postmaster. In a recent interview Mrs. Pears told us she was helping to drive a group of choir-girls from Calgary to give a recital at Drumheller. Her group was in the second of two cars.

They had stopped at a railway crossing outside Drumheller, she recalled, when a brilliant object appeared directly over the car in front.

"It was a fluorescent blue, sort of vapory, and it had an orange tail like a jet," she recalled. "But it wasn't any plane. It was smaller than that and shaped something like a torpedo. It

seemed to be no higher than the top of the telephone poles."

As the first car moved on, the object flew deliberately toward Mrs. Pears' car and repeated its hovering manoeuver. Seconds later it streaked out of sight, leaving the girls far more excited about its performance than the one they themselves were soon to give. Unknown to them, a similar object had just escorted another car for 10 miles along the same highway, terrifying its occupants.

Had the ufoperators, for some reason of their own, chosen that particular time and method to show their possessive rights to the ancient marine-beds of Drumheller?

ROADSIDE VISITORS

Although Drumheller and Rosedale are located in the "badlands" of Alberta, the implication that they are surrounded by ugliness is misleading. Like other such areas around the world that were scarred by escaping seas as the earth's crust buckled, this part of Alberta has the bleak, timeless look of a lunar landscape. But, just as men on the moon have discovered, it has a raw beauty of its own, a fascinating one that seems etched forever in the hollow of the coulees and the colored layers of stratified rock.

It was here on the night of June 7, 1971, that three small strange visitors came to call in a box-like craft that seemed to arrive from nowhere and leave the same way. The witness to this startling event was Miss Esther Clappison who for many years has shared a house on the outskirts of Rosedale with her brother Bill.

"It was the night of a full moon," she recalled, "when I noticed a light coming through one of our windows. I couldn't see what it was all about so I went around to the front of the house where there is a porch. With me was my old yellow dog called George.

"I was surprised when I got there to see a rectangular-shaped lighted object down on the ground near an intersection of two roads." (The intersection of these two small dirt roads is about 200 feet from the house.)

Although startled and uneasy, Miss Clappison quickly began taking in details of the unexpected scene. The end of the object facing her appeared to be wide open, exposing some of the interior and allowing a white opaque light to

illuminate the road. In its glow she could see three human-like figures, all appearing to be under five feet in height. Two were inside the object and the third was busy with something across the road.

Sensing the object had indeed come literally from the blue, she remembered in the same instant one of Bill Allan's UFO broadcasts in which he urged witnesses to look for the instrument panel.

"So the first thing I did was look for one," she said, "and I saw something that looked like a panel at the far end of the object. But one of the men, if that's what they were, seemed to have realized someone was looking at them and he had covered as much of the panel as he could by standing with his back against it and stretching out his arm. He continually kept looking backwards to see that his arm was covering whatever was in front of that craft."

As Miss Clappison watched, not daring at first to move, she saw this crew-member (Allan later suggested he may have been grasping one of the controls, ready for a quick take-off) motion to the second one inside the craft who was standing to the right of the entrance, leaning out slightly as if to catch the attention of their colleague across the road.

"The man out there was obviously picking up samples," Miss Clappison continued. "I guessed it was rock, not dirt, because he was picking, not scooping. After a moment I tried to get closer and have a real eye-full but the old dog wouldn't let me. He was scared to death and he pushed me right back. That was quite a push, you've got to admit. Well then, I came in but to be honest I wasn't that fussy about getting much closer to that thing.

"Anyway, I came in to attract my brother's attention. Then I looked through the window to see the object again, and what they were doing, but there wasn't even the light. When I returned with my brother there was nothing there, and so help me I hadn't been drinking. I'm not a drinking woman."

But there was something there. Next day when Miss Clappison and her brother walked over to examine the area, they discovered a scorched imprint at the edge of the road where the object had been. Twenty feet long, the blackened imprint on the roadside weeds had a narrow rectangular shape as if the object had been only partly off the road.

Four months later the mark was still plain enough for Allan to make an exact measurement, and three weeks after that we saw



Clappisons at landing spot (partly seen, lower right).

it for ourselves.

As for the other dimensions of the craft, Miss Clappison estimated it was eight feet high and five feet wide. The panel in front seemed to occupy the full width of the interior.

Of special interest, of course, were the three occupants. According to the witness, they wore a close-fitting uniform of olive or drab green and snugly shaped headgear of the same material. Their faces were also covered but apparently by some sort of fabric through which they could see (a detail of dress noted in other occupant sightings).

Miss Clappison particularly noticed the occupants' wrists which she said were thin and flexible. She thought they were wearing a kind of "pointed mitten" with a long, slender thumb.

While the stones and small rocks at the roadside were of a common variety, our guess is that those humanoids believed they were gathering something considerably more important than a random assortment of rubble. The area around Drumheller is one of the great preserves of nature's relics and scientists have dug there for some of the finest fossil discoveries ever made. So it is not as a joke that the town features giant relics of ancient mammals as a tourist attraction.

Evidently our UFO visitors have also discovered the area's scientific value and, just as our astronauts have sought out the lunar highlands, so these visitors focus attention on "badlands" like Drumheller's to learn more of this planet's natural history. Perhaps after examining those stones from Rosedale, the

members of that particular craft will, like our astronauts, find it necessary to come back for more and dig deeper . . . or maybe they know how to obtain all their information from surface residue.



Clappison house seen from landing area.

BADLAND ROVERS

Less than four months after the Rosedale incident, Joe Klimek, an oil company employee operating out of Drumheller, and two others came upon a remarkable sight suggesting space visitors in that area are, like earth's astronauts, not always content with just scratching the surface. In fact, comparison between what they saw and what an Apollo landing craft would look like in a lunar crater is uncannily close.

Klimek, who has been with his company 15 years, is in charge of all its metal construction work in the Drumheller oil-fields. One can imagine his surprise, therefore, when he saw a totally strange metallic structure down in a coulee — one of the dead-end canyons cutting through the countryside — where his company's equipment was operating.

His remarkable experience occurred about 4:30 p.m., Sept. 23, 1971, as he was taking his sister and brother-in-law to see a rare fossilized oyster-bed found in that particular coulee.

"We had just driven out there," he said, "when we saw an object on the opposite side of



Overlooking canyon of Klimek sighting.

the canyon that I had never seen before. We kept looking at it but there was no movement of any kind so we drove down to the oil-field at the bottom of the canyon to get a better look at it. But still there seemed to be no movement."

Klimek described the object as somewhat squat and squarish-shaped, measuring perhaps 12 by 12 feet at the base and standing about 10 feet high. It had a "pointed top beveled on one side" which, we gathered, meant the sloping upper surface angled out slightly on that side. The object was a metallic "bluish-gray."

As there was no sign of life and no ready way of climbing the cliff to have a closer look, the mystified witnesses finally returned to their car and drove off.

But next day they were back, this time driving through a farmer's field on the other side of the canyon to a point directly above the ledge where the object had stood. It had gone.

"There is no way a thing of that size could have been lifted out of there without making it a major operation," Klimek said. "Even if a helicopter had managed to do it, there would have been tracks all over the place, getting the thing hitched up. But there was nothing like that at all. If it didn't fly off under its own power, I don't see how it got away."

As it turned out, there *were* tracks but such unusual ones they only increased the mystery. Klimek, now wearing stronger boots, discovered them when he climbed down into the coulee to have a better look and also bring his sister a promised oyster.

Studying the clay slope just above the spot

where the object had stood, he saw "about six" oval-shaped marks, each about six inches long, leading to a grassy bank above the ledge where they disappeared. The marks were spaced about 30 inches apart and proceeded in a straight single-file line to the bank. The depth of the prints, less than an inch, was about the same as Klimek's own heel-marks.

Klimek's impression was they must have been made by someone climbing up the hill. This leaves us awkwardly trying to visualize someone with tiny club-like feet, and the stride of a tall man, firmly mounting that sharp incline with the precision of a tight-rope walker.

Perhaps it was such a person who made those marks. But perhaps it was something else — equally strange but fitting closer to a pattern of other UFO mysteries. To explain what we mean let's go back to a case related by M.B. Gaunt in Canadian UFO Report vol. 1, no. 4. Gaunt told the documented story (see also 'This Baffling World' by John Godwin, Bantam Books, 1971) of strange tracks that appeared overnight across the snow-covered countryside of Devonshire, England, in the winter of 1855. The tracks, somewhat oval- or hoof-shaped, and slightly convex in the center, proceeded in a straight line for about 100 miles over all obstacles, including water and buildings. Though widely reported and speculated on in the press, the mystery was never explained.



*Devon prints reproduced in
'London Illustrated News'
March 3, 1855.*



We were reminded of this case recently by a UFO-landing report in 'Spaceview' published by Paradise at Vidor, Texas. The incident occurred during 1965, at Custer, Wash., and involved an observed object that left a circular print in the snow. The report continued:

"Leading away from the UFO imprint were tracks — oval-shaped about eight inches long and the same distance apart in single file. These tracks led from the imprint in the snow toward a road about 75 feet away, stopped at the barbed-wire fence, made a straight line across an open field for several hundred feet, made an acute right angle turn and disappeared into a clump of evergreens. The tracks were unique; they were not an impression in the snow but appeared, instead, humped up as though the snow had been sucked up into a vacuum tube oval in shape. The next morning a geiger count of the incident was made and the tracks and circular imprint were far above the normal background count of the area. It was also noted then that the tracks had approached the fence uninterrupted, in a straight line, and equidistant in spacing. They had lifted up to clear the fence and returned to the snow on the field across the road."

Note the distance between prints — eight inches. This was precisely the distance between the mysterious prints made 117 years ago in the snow of Devon. Considering also the convex oval pattern in both cases (though the English prints were about half as long), the exact single-file sequence and the weird ability to surmount obstacles, it seems likely that some sort of mechanical contraption strikingly unchanged over the years, rather than a living creature, was responsible for both sets of prints. Although the spacing was greater at Drumheller, other details were basically similar so this seems to be a third incident of the same variety.

Since in the two contemporary cases the tracks led from an observed object, it would appear they were made by a secondary device for maybe just the same exploratory purpose that Apollo crews drive their rovers on the moon. Stretching our imagination a bit, we can picture the device as a single wheel with traction-giving pads projecting from its rim and its balance maintained by gyroscopic effect. In motion it might resemble a flying saucer rolling along on its edge.

For clearing obstacles there might be a small thrust system more compact than the mothership's anti-gravity equipment. Finally, a ufoccupant may be crouched in the hub, driving the thing. If he is true to UFO form, he will do

his trickiest best to leave us wondering whatever made such peculiar tracks.

Bringing back a fossilized oyster as promised, Klimek returned to the cliff-top also carrying a small L-shaped brass rod he found near the site. It was pointed at one end and sawn straight through at the other, with the saw-marks clearly showing. It was an ordinary-looking bit of metal that might have been dropped by one of the oil-workers.

But Klimek can't see what it's for, so he's keeping it just in case . . .



Joe Klimek, holding rod found at site.

"PLANETS" AT LARGE

SAN DIEGO, Calif. (AP)—Astronomers have discovered a strange object sandwiched between a galaxy outside earth's and a Quasar, says Prof. Geoffrey Burbidge of the University of California.

It is not a star "but what it is, we don't know," Burbidge said here.

A photograph of the object was taken six weeks ago by the 200-inch Hale telescope at Palomar Observatory by astronomer Halton C. Arp of the California Institute of Technology.

Burbidge said he and his colleagues are "thoroughly baffled."

His wife, Dr. Margaret Burbidge, a noted astronomer also at the University of California at San Diego, has been trying to identify it at California's Lick Observatory. She refers to it only as a "nonstellar object."

Burbidge said the photograph showed it between Galaxy 455 and one of the quasi-stellar objects known as Quasars. His wife estimated the galaxy is about 100 million parsecs from earth. A parsec is an astronomical measuring unit roughly equal to 19.2 trillion miles.

Burbidge, a world renowned cosmologist, is a professor of physics at UC's San Diego campus.

If flying saucers really do exist, why are they never seen by astronomers? As everyone interested in the mystery well knows, that is a favorite question of the skeptics. The answer, of course, is that flying saucers—or, at any rate, celestial objects without a fully acceptable explanation—are indeed seen by astronomers, and the above case reported by Associated Press, Oct. 2, 1971, is not an isolated one. Here is another, reported in Circular No. 2303 of the International Astronomical Union:

On the morning of Jan. 22, 1971, C. Roger Lynds of Kitt Peak National Observatory in Arizona had an unusual experience while working at the 84-inch reflector. The instrument was pointing toward the constellation Sextans when he became aware of a moving object that resembled a star of magnitude 10½ or 11.

Dr. Lynds kept the object in view for several minutes as it traveled northeastward among the stars. . . Its motion was roughly estimated as two seconds of arc per second of time. According to the announcement, "the object was stellar in appearance and less than 1.5" in diameter.

The object has been tentatively classified as a fast-moving asteroid. But, if that is correct, it is puzzling why an asteroid of such prominence was not among those already charted.

Another more celebrated case occurred on Aug. 7, 1921, when a curious happening in the sky was seen by a group gathered at the Lick Observatory on Mount Hamilton, California. The incident was announced in this message:

"Star-like object certainly brighter than Venus three degrees east, one degree south of Sun seen several minutes before and at sunset by naked eye. Five observers. Set behind low clouds. Unquestionably celestial object. Chances favor nucleus bright comet, less probably nova."

Later it was made known that when the sighting occurred, Observatory director W.W. Campbell and his wife were entertaining guests at the director's residence. One was Henry Norris Russell, director of Princeton Observatory. Another was World War I flying ace Capt. Eddie Rickenbacker. Also there were Major and Mrs. Reed Chambers.

From the house porch they were watching the sunset when Major Chambers asked the identity of a star he saw left of the sun. Then, in Campbell's words, "Captain Rickenbacker said that he had been watching that star for several minutes but had not mentioned it because he supposed it was well known. Major Chambers said that he had seen it at least a minute or two and had not spoken of it for the same reason.

"Mrs. Chambers, Professor Russell and Director Campbell saw the starlike object immediately. Mrs. Campbell went into the house to secure a pair of binoculars. Within a minute she had handed them to Director Campbell who saw the object in the binoculars



William Wallace Campbell



Henry Norris Russell

not more than two seconds before it disappeared behind the horizon cloud stratum.

"The five observers agreed that the object was starlike. Director Campbell remarked that it was probably Mercury, but Professor Russell said at once that it was entirely too bright for Mercury. . .

"Russell and Campbell agreed that the object observed was brighter than Venus would have been if seen in the same position and circumstances as the strange body. The observers had no reason to doubt that

the object was genuinely celestial, as in the binoculars its diameter still seemed stellar. It seemed to partake of the diurnal motion of the stars in that it moved down toward the lower cloud stratum and disappeared behind it. To imagine an object in our own atmosphere which would have supplied all of the phenomena described seemed entirely too difficult."

It was obvious from all this that the witnesses were looking at something of planetary proportions. Yet just as obviously it was not a planet. As news of the sighting spread, other reports of the same object came from various parts of the world. An English observer said that while studying the same area that same evening with his binoculars, "I alighted upon a bright object, which I at the moment thought was Jupiter, but the next moment I saw was not a planet at all; neither did I think it was a star. It was elongated in the direction of the Sun, and was of a distinct reddish tinge."

After a while the guesses about its being a nova or the nucleus of a comet began to seem just as unlikely. For one thing, it was never seen again, which virtually eliminated the nova theory. Also its position was wrong both for a nova and for membership in the family of sun-grazing comets whose courses are well known.

So we are left with the mystifying thought that one evening 51 years ago a great unknown body appeared briefly above earth's horizon — behaving like a star but not a star, the size of a planet but not a planet. Now we wonder how many other strange objects of such huge dimension are coursing the freeways of space and for what purpose — and who, if anyone, is aboard?

That Well-Made Look — Plus Occupants

UFO Review published by the California UFO Research Institute, of which nuclear physicist Stanton Friedman is director, always contains items of substance. Here is one from a recent issue. It caught our attention because of the solid, precisely-tooled quality of the object observed and because, as the Review pointed out, there were said to be many witnesses.

The following sighting report was received from Mr. Mills Grantham of Texas on November 11, 1971. This sighting is specially interesting due to the number of witnesses purportedly involved. The report is quoted verbatim as follows:

"In November, 1959, coming from Abilene, Texas, southeast on highway 36 at 3:00 p.m. about 30 miles from town to the Denton Valley community and the Denton Valley Atlas missile site on FM 604, driving U.S. Army Carry-all 5480, and employed by the Corps of Engineers (Military), about 100 cars headed each way were stopped and most of the people were out looking up. This was about one-half mile from the flasher at FM 604 intersection and two and one-half miles from the

missile site. I stopped my vehicle in the road near the center of the group of cars and got out and looked up (leaving the Carryall running). Numerous cameras were taking pictures in the group of about 300 people present.

"The reddish-orange flying saucer appeared to be 30 feet in diameter with the pronounced circular ring on the bottom. The straight circular walls appeared to be 8 feet tall with round portholes of plexiglass, with yellow-orange, two inch trim around portholes (and) around the bottom and top of the wall. The saucer appeared to be about 200 feet above the center of the highway and was completely stationary and emitted no sound. No one knew how long it had been there.

"After about 10 minutes I went on to my missile site and called an electrician named S., (and asked him) to get his binoculars and we climbed the 50-foot spoil-pile. We watched about ten minutes when we saw a jet fighter from Dyess AFB come through the notch in the hills.

"The saucer went the long leg of the triangle and crossed in front of the jet in the direction of the town of Winters. The jet had about 4 miles to go to head-off the saucer which had about 6 miles to go to cross in front of the jet. They appeared to be about a half-mile apart but the saucer had so much speed it left the jet like it was standing still.

"The saucer did not spin or emit any visible exhaust as we watched through the binoculars. The incident was not in the Abilene papers.

"This same report was sent to Colorado University, I think in 1967. The reply was that they could not use the information."

In response to a letter requesting more information the following reply was received on December 7, 1971:

"(In response to your questions). . . There was no glow at any time and the reddish-orange color was dull on a metallic surface which was smooth. The object had its bottom to the ground with straight sides at right angles to the ground. It didn't change its attitude to the earth when it was in motion, neither was there any whirling or rotation. Portholes were noted on three sides, about eight feet apart and two feet in diameter. Trim was bright yellow-orange.

"Sighting was made on Wednesday near the middle of November, 1959. Weather was clear with no clouds in sight and plenty of sunshine. U.S. Army vehicle I drove had no radio. Had receiving and transmission set at missile site, but climbed spoil-pile to watch with binoculars. My vehicle was running all the time and so were a number of other cars. It had no effect on my speedometer or my watch.

"Hold a plate above your head. Note the rim it sits on when on the table. It did spark out and appeared to be exactly the same as the plate and twelve feet across. Could even see a large portion of the top rim.

"All vehicles going in each direction were pulled off the pavement, and onto the shoulder except mine which I stopped in the middle of my lane. No other car arrived from either direction while I was on the highway."

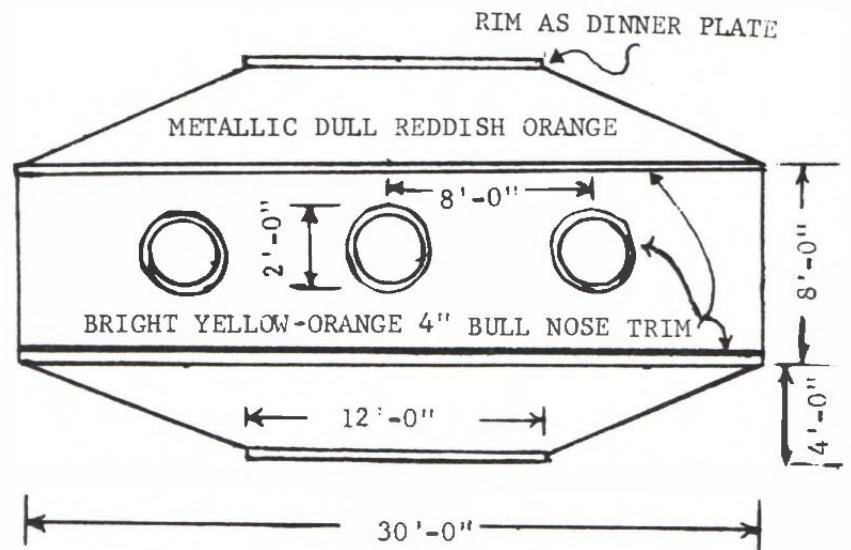

UFO AT ABILENE TEXAS
1959

In a back issue of UFOIC Newsletter published in Sydney, Australia, we happened recently to come across a report of another highway incident involving a solid, tooled hovering object. But in this case something new was added – occupants. It will be noticed one of them spoke to the witness in a way he understood and we assume this was by some means of telepathy, a facility sometimes noted in UFO reports.

Under the heading "Brazilian Landing" this is the account carried by UFOIC Newsletter:

The following cases were investigated by Dr. Methodios Kalkasliet and Dr. Max Berezavsky, on behalf of Professor Flavio Pereira and the Brazilian Commission for the Confidential Investigation of Unidentified Flying Objects.

A highway patrolman, whose name has been withheld, was on duty on Kilometer 124 last November (1968), when he witnessed what he thought at the time to be a plane crash. On drawing closer to the grounded object, he noticed to his surprise that it had actually stopped in midair 50 metres above the ground and was totally unlike any conventional aircraft. He described it as being "as high as a fifteen-storey building and elongated". It seemed to be made of aluminum, showed outward riveting and apparent hatchways and appeared to be spinning. Just as the patrolman was about to leave for assistance from his patrol post, the strange object emitted an extremely powerful aura of lights with a glare like welding torches, only "millions of times brighter". A very loud humming noise began to vibrate also, and the patrolman, sensing a headache coming on, ran to his car. Terrified, he discovered that it would not start. In the distance the lights of the police cabin had flickered off when the object was nearby, but came on again as it rose higher in the sky. The patrolman found that he was now also able to start his car. The policeman hurriedly reported the incident to the policeman on duty, and the two drove back to the scene of the incident. All that could be seen was a very bright light high up in the sky.

Two nights later, at 2:30 a.m. on November 28, the same patrolman experienced a similar sighting involving what seemed to be the same object. Seeing the object in the night sky, the policeman hurried from his car and hid himself in a bushy ditch with his loaded revolver near at hand. He was hidden from view as the object drew near and hovered about 30 metres above the ground, 50 metres away from the patrolman. He did not know whether to fire or not, and while pondering on the thought, watched as two "frogmen" emerged from a hatch on the underside of the craft. Illuminated by dull light, they wore skin-tight clothing with wide belts around the waist which glittered with lights in various places and seemed by their gestures to be aware of his presence in the bushes by the ditch. One of the beings

spoke to the patrolman, telling him to put his gun away, since they meant no harm and would be returning to the spot later. After hearing this the patrolman got up to leave and found that he could not control his legs which felt weak beneath him. Meanwhile, the object took off and disappeared. The patrolman eventually reached his car and later submitted an official report to the Commandant of the Highway Police in Sao Paulo.

UFOs of enormous size like this are an imposing part of our visitors' armada. A year before this incident a craft of similar dimensions was seen landing in the Cariboo country of British Columbia. Witnesses said it was at least equal in size to "a spacious office building." (Vol. 1, no. 6)

COVER STORY OUTSTANDING PHOTO

"At 8:30 a.m. Sunday, February 27, 1972, Mr. Les Roll obtained two color photographs of an unidentified flying object near his home in Mart, Texas, showing considerable detail."

This terse opener to a press release sent out by International UFO Bureau of Oklahoma City (of which CUFOR contributing editor Hayden Hewes is a director) was our introduction to a picture containing perhaps some of the finest UFO detail ever photographed.

(While Hewes did not have a copy of the other photo — first of the two taken — for release, his Bureau had an analysis report on both Polaroid prints from Tommy Blann, its representative in Texas, who had made an on-the-spot investigation of the incident and was satisfied no trickery was involved. In a talk later to the Bureau's Third Annual Symposium, Blann reaffirmed this view.)

The Bureau's statement, based on Blann's findings, continued:

"Based upon precise measurements and estimates, the size of the object was determined to be 50-60 feet in diameter and its altitude was calculated at 700-800 feet. The height of the object as pictured is between 17-20 feet and its rim extension is about three feet. The black section underneath, apparently circular, is about 25 feet in diameter. It does not appear to be centrally positioned, according to the angle at which viewed. This, however, might indicate that the dome section on top is not in the middle.

"Based on sunlight reflection, the object appears metallic in nature and may have been in an electro-magnetic field. It was noted that there were animal reactions. Sheep would not eat the following day and dogs were restless."

The Bureau added these two possibly significant points:

Further investigation revealed there was a local power failure about 20 minutes after the object was sighted. The power failure lasted for 15 minutes.

Les Roll informed Bureau investigator Don Garcia that the FBI told him not to release the original Polaroid color photos.

In his written report, Blann gave these further details:

Magnetic bearing of the object from Roll was 55 degrees, elevation 32 degrees. Bearing of the sun was 102 degrees, elevation 10 degrees.

Day was clear with 15 percent cloud coverage. Temperature 52 degrees F.

In reference to the photo shown here Blann said:

"It will be noticed that at the top of the object to the left there is a small light which could be a reflection through some type of lens on the object. Or it could be a defect in the emulsion of the film. There is an arc above the dome section which seems to contain sections instead of being a smooth metal arc. On the dome section there is a bubble-like protrusion to the right, indicated by the reflection of sunlight. In the middle of the object (just left of the light reflection) is a darker portion which cannot be made out clearly as to what it is.

"The rim around the craft apparently is a one-piece construction, for it is smooth, showing no indication of two pieces being joined together. Otherwise there would be a little shadow play there.

"The camera used was a 60-second Polaroid, color photos."

Although Tommy Blann has carefully considered reasons for disagreeing with our views, and explained them to us at the Bureau's Symposium, we respectfully question whether the section on top reflecting sunlight is

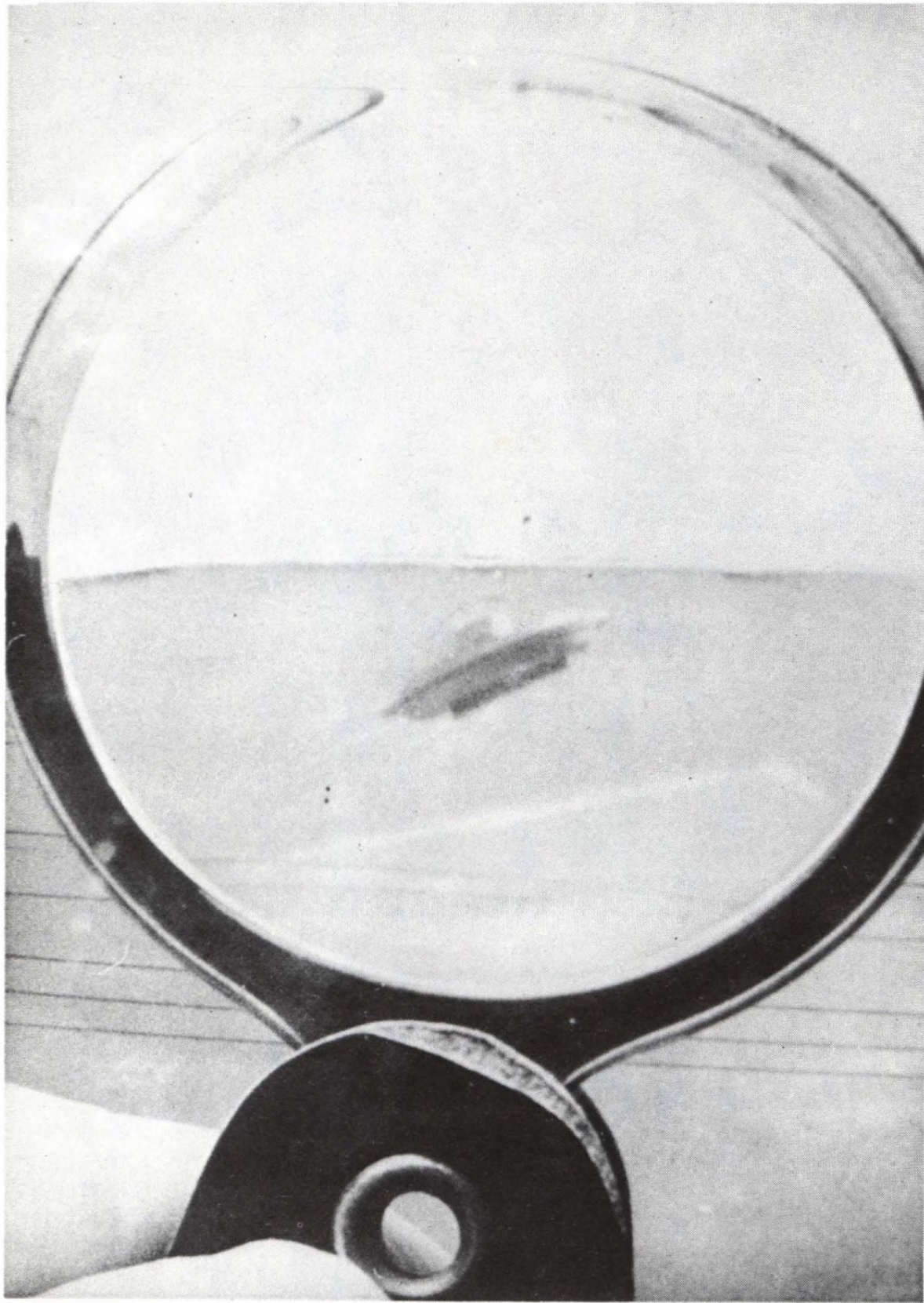

No, this is not shot of unidentified submerged object taken through porthole. It is remarkable UFO photo described here as seen through hand-held magnifying glass. Horizontal line through middle is top edge of print. Parallel lines underneath are power-lines, and light squared area is reflection from glass.

really the dome as he has indicated. We suspect it is the instrument panel, and the arc above is a transparent dome outline which for some reason looks shortened on the right-hand side.

We favor this view because:

- *A transparent canopy is often noted on UFOs of this type.*
- *There are two dark marks on the upper part of the section in question which could well be instrument faces.*
- *A glass-like dome might account for the light mark to the left as an additional point of reflection.*
- *The instrument panel has been noted as a dominant feature in this type of UFO.*

(In vol. 1, no. 7, witness Doreen Kendall reported the same type containing a panel exactly as it would look in this photo. Miss Kendall and others have described seats in front of the panel. Could that dark mark be the back of just such a seat? Although almost lost in reproduction, there is one other dark mark — maybe two — to the left of the main one, just poking above the metal body of the craft. Is it an instrument or another seat or, by some extraordinary chance, a ufoperator's head?)

As intriguing as the panel — if that's what it is — is the dark section at the craft's bottom. It is surely too large to be just a landing pad. We suspect it is the power plant and that within that single piece lie many of our visitors' most vital secrets.

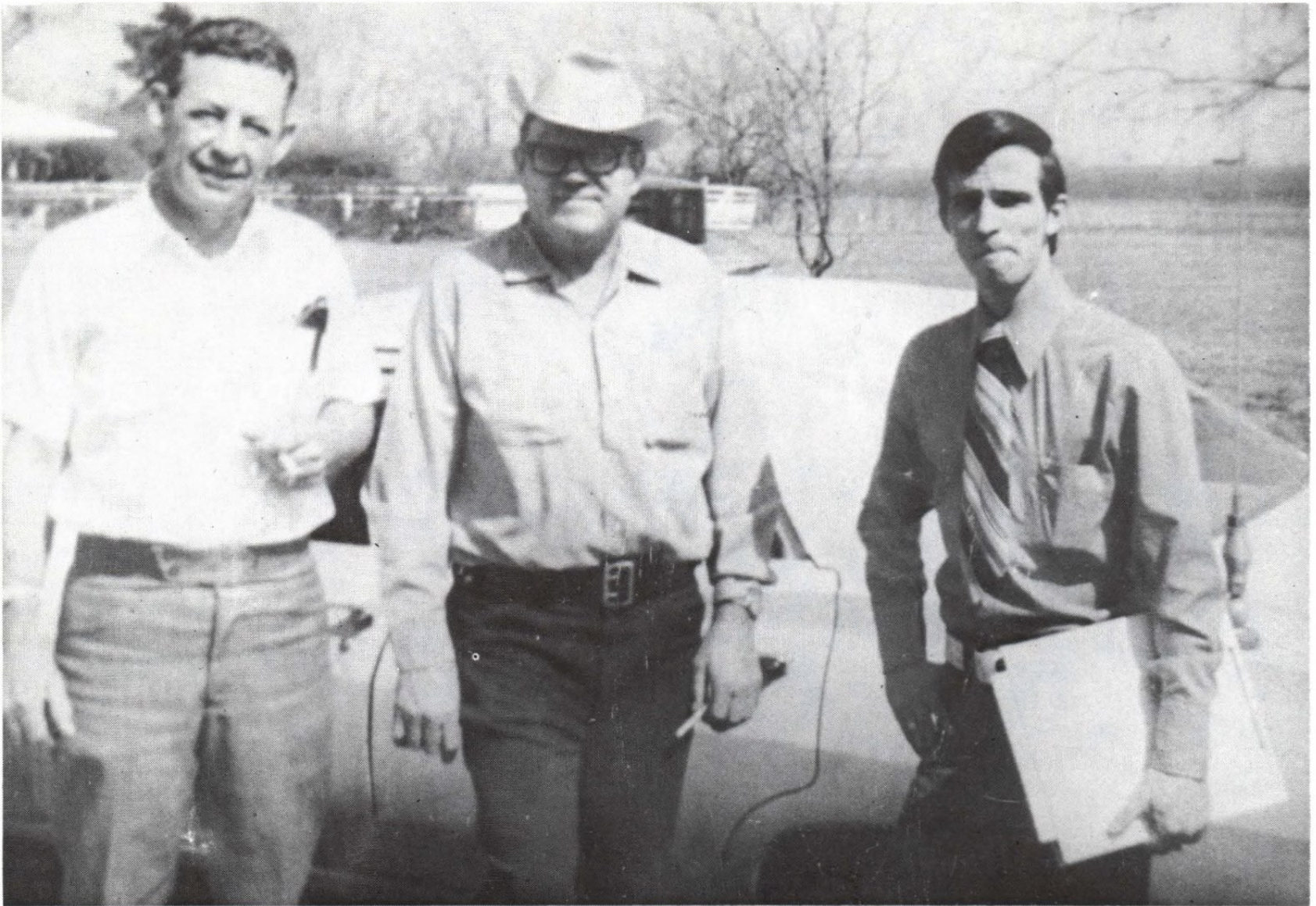

Les Roll (left), who took picture on preceding page, said object was zig-zagging silently across sky and was obviously not plane or helicopter. With him are Haskel Fife, chief of police in Mart who reported case, and Tommy Blann, UFO investigator.

NOTHING IN PRESS?

One usually reliable measure of UFO activity around the world is the volume of press coverage it receives. To judge from the excellent clipping service provided by Rod Dyke of the UFO Research Committee in Seattle, Wash., activity is at a high level.

Two examples are not nearly enough to show what is going on, but we carry the following because of their unusual nature. It will be noted in the second story from England that an attempt was made to explain away a strange light as St. Elmo's Fire. But note the spokesman did not use the witness' exact words. She spoke of being "held in a tube of light," an experience noted before in UFO activity. Her comments were not precisely mentioned in the attempted explanation.

The first story is noteworthy because it concerns one of the comparatively few cases where occupants' voices may have been heard.

Santa Ana (Calif.) Register (Dec. 12, 1971)
By Lawrence Kirsch

The claim of three Santa Ana hunters that they saw a flying saucer land on a rugged plateau in the Lucerne

Valley and its mysterious occupant emerge to explore a portion of the Mojave Desert is being probed by the National Investigation Committee on Aerial Phenomena (NICAP), a spokesman for the organization said Saturday.

"We're right in the middle of the investigation at this point, so I can't really make a statement about how valid the sighting is," Mrs. Idabel Epperson, chairman of the Los Angeles branch of NICAP, said in a telephone interview. "I will say, though, that the three men who reported it seem pretty firm in their belief that they actually witnessed the landing and saw someone or something leave the space vehicle."

The incident occurred on a hunting trip in the Lucerne Valley last month, Mrs. Epperson added.

In an exclusive interview with The Register, the three men, who prefer to remain anonymous because they fear ridicule, told their story.

"It sounds crazy, I know," one of the three said. "And if I hadn't seen it myself, I wouldn't believe the story. I never even thought about flying saucers before.

Now I'm a believer."

His hunting partners nodded in assent.

"It was a Saturday—Nov. 13—and we had been hunting all day," the second man said. "It was getting dark and we decided to set up our camp just below a ridge in the valley."

The third hunter interrupted: "That's when we saw the first saucer. It came out of nowhere and was hovering over the San Bernardino Mountains. It was the brightest thing I've ever seen and about the size of a car."

All three men agreed that the UFO was disc-shaped and disappeared after a few moments.

"Then we saw another one," the first hunter said.

Mystified by the objects, the three men climbed a ridge near their campsite to get a better view of the valley.

After approximately 10 minutes on the ridge, the Santa Ana men said they saw a self-luminous, football-shaped object dropping from the sky.

"It descended very smoothly to mountain-top level," one of the men recalled, "continued down the contour of the mountainside, across the desert floor and finally settled on a small plateau.

"The next thing we knew, something got out of the craft and started scanning the area," said another of the hunters. "It wasn't walking on the ground like a human, but was gliding above the brush."

The first hunter picked up the thread of the story.

"It seemed like only a few minutes, but already the thing was almost up to the hill we were on," he said. "At this point we wanted to signal it with a flashlight, but we were scared and began running in the opposite direction toward camp."

Sitting with their guns pointed at the ridge, the three men waited.

"Within a few seconds we heard branches crackling, but didn't see anything. All of a sudden there were two unintelligible cries — at least they were unintelligible to us."

The hunters spent the night huddled in their sleeping bags.

"At sunrise, we started to hike where we thought the saucer had landed," one of the men continued. "About 30 minutes later, after searching two plateaus, we found something. There were five round impressions in the ground. Three of them formed a triangle. The other two were together, 10 feet off to the side."

The three believed the impressions were made by the saucer when it landed.

"It's bizarre, but it's true," said the first hunter.

The hunters have returned to the plateau twice, once with NICAP investigators.

"It'll be some time before we conclude our investigation of the sighting," Mrs. Epperson said. "But if the reports we have are accurate, it may become a classic example that flying saucers do exist."

Sunday Express, London, Eng. (Sept. 26, 1971)

by Robert Chapman

Nothing, it seemed, could ever disturb the sleepy riverside village of Shaldon, Devon . . . until it reeled under the shock of 50 million volts.

One moment all was afternoon stillness and silence. The dark cloud drifting overhead seemed harmless. Then suddenly the whole village was scared by a violent flash of lightning and thunder echoed down the valley.

People collapsed in pain. High plumes of water were seen to spurt out of the River Teign. Two women were enveloped in shrouds of fire. Electrical instruments abruptly burned out.

Some people had to have medical treatment for mysterious aches and partial paralysis—and were still going to their doctor weeks after the lightning struck.

A village doctor said: "I had, four patients with symptoms attributed to the flash." He thought there were many others who did not seek medical help.

Today, more than a month later, there are people in Shaldon who are not convinced that the flash was due to ordinary lightning.

Was it, they wonder, caused by a large meteorite—or something even more sinister from outer space? Did it have any connection with sightings of Unidentified Flying Objects reported from different parts of Britain the week before?

Village ironmonger Mr. Tom Underhill said: "There was just one flash and a bang coming together. It wasn't like ordinary storm lightning with the thunder following after an interval.

"There was no rain and nobody saw anything drop from the skies. But some people say they saw the river spurting up as though something had fallen in it."

Market gardener Mr. Lovis Peterson, 62, was one of those who visited his doctor after the lightning flash knocked him to the ground.

He said: "I felt a terrible pain. When I recovered I was still shaking all over and since then I've not been able to keep my balance properly. My neck aches and I can't use my right leg normally."

Housewife Mrs. Betty Connell was one of the two women who found themselves "trapped" in a circle of brilliant light.

"I didn't feel anything," she said. "But I was aware of being held in a tube of light. It took me several days to get over the shock."

An expert on lightning who does research for the Central Electricity Generating Board said yesterday: "The flash was caused by electricity building up in the dark cloud and then abruptly spilling over. It could have had the force of 50 million volts or more.

"As for the glowing shroud that enveloped Mrs. Connell and the other woman, these were almost certainly examples of St. Elmo's Fire caused by air in their vicinity becoming ionised — electrified — and appearing to burn."

But still in Shaldon they wonder.

FROM DR. McDONALD'S FILES

A few months after our first issue appeared in 1969 Dr. McDonald, professor of meteorology at the University of Arizona and an outstanding ufologist, expressed interest in Canadian UFO Report and generously began sending in material, including studies of his own, that he thought would be useful for reference. And so it was. We greatly valued this association.

Now, going through the material again after his saddening death last June, we feel there is a great deal of it that should be kept for the printed record. Accordingly from time to time we shall publish portions of his work that we have on hand. The following is part of an address he made in March, 1968, to an astronautics symposium held at Montreal by the Canadian Aeronautics and Space Institute. Some of the incidents mentioned will be familiar to readers but we suggest they have a place here because Dr. McDonald singled them out for special attention.

One of the conclusions one must draw from studying UFO reports from all parts of the world is that there is an essential similarity in the types of unexplained phenomena reported from all parts of the globe. Discs and cigar-shaped objects dominate; nighttime observations are most common; and highly unconventional performance characteristics are described by observers in widely varying geographical areas, and by observers of quite diverse cultural backgrounds (primitive groups as well as more advanced groups). To bring out certain of these points, a small number of specific cases will be briefly summarized next.

Case 1. BOAC Stratocruiser, Seven Islands, Quebec, June 29, 1954.

A famous case in UFO annals that has an appropriately international flavor occurred near sunset on June 29, 1954, over eastern Canada, when crew and passengers of a British Overseas Airways Corp. Stratocruiser, outbound from New York to London, observed, for a total period of *18 minutes* (about 90 miles of flight path) one large object and five or six smaller objects somewhat north of Seven Islands. The UFOs were sighted just aft of the port wing, at a very roughly estimated distance of 5-6 miles, maneuvering in unconventional manner. Capt. James Howard, the pilot, stated, after landing in London, ". . . they were obviously not aircraft as we know them. All appeared black and I will swear they were solid . . . There was a big central object that appeared to keep changing shape . . . The six smaller objects dodged about either in front or behind." When interviewed by USAF intelligence personnel at Goose Bay, Labrador, it was established that all of the crew had participated in the sighting, as did a number of passengers, a total of over 20 witnesses. A fighter plane scrambled from Goose Bay at Howard's request. Just before it reached their area, the UFOs moved out of sight towards the northwest.

The group of UFOs maintained relatively constant position, relative to the airliner, until their departure, and lay approximately five degrees to left of the just-setting sun. No meteorological - optical phenomenon (assuredly not a sundog) could reasonably account for the reported phenomena. The Stratocruiser was cruising at about 240 knots at 19,000 ft. on the southwest edge of a high-pressure center over Labrador, scarcely meteorological conditions favorable to ball lightning or any other electrical disturbances; and visibility was described by Capt. Howard as "perfect." To suggest that a natural plasmoid of any sort could keep pace with an aircraft at 240 knots for 18 minutes and 90 miles seems entirely unreasonable on a number

of grounds. The speed and motions categorically rule out meteors. The peculiar maneuvering of the smaller objects and the curious shape-changes of the larger object suggest no conventional explanation. It was First Officer Lee Boyd's impression that the smaller ones merged into the larger prior to departure, again defying obvious explanation.

At that time, Howard had 7500 flying hours; he is still flying with BOAC. In a recent interview, he corroborated details of the 1954 press accounts and even added interesting additional points. The distance of the objects precluded seeing any structural details, if any had been present; it is the performance characteristics and the pronounced shape-changes that mark this well-authenticated sighting as a puzzling UFO case for which no adequate explanation has ever been proposed, to my knowledge.

Case 2. Cressy, Tasmania, October 4, 1960

A half-dozen years after Case 1, and halfway around the globe from Quebec, a well-documented sighting bearing a certain resemblance to it (a number of small objects around a larger one), was made by two reliable witnesses. Rev. Lionel B. Browning, an Anglican clergyman, was admiring a rainbow as he and his wife looked out a window of the Cressy, Tasmania, rectory. It was 6:10 p.m., the sun was just setting in the west. A curtain of rain concealed Ben Lomond ridge off to their east and extended through the southeast and to their south. Mrs. Browning suddenly called Rev. Browning's attention to what they both first interpreted as a large aircraft emerging from a rain-curtain nearly due east. Although the Brownings never felt entirely sure of the range of this object, they estimated it at perhaps 3 miles, since the object seemed to be over an estate known to be at that distance. Their first guess that it was an aircraft was next modified to an aircraft stalling, since the speed of the object, crudely scaled from the subjective size-and-distance estimates, seemed to be not much over 50-60 mph.

I had an opportunity to interview Rev. Browning last summer and verified contemporary press accounts. He and Mrs. Browning quickly noted that the cigar-shaped object seemed to lack wings, had several vertical bands or ridges on its gray-colored surface, and some odd protuberance on its "forward" end. They watched it glide northward for about a minute before it suddenly stopped in mid-air and hovered over the ground at an altitude they very roughly guessed at 400-500 feet. Then, from out of the rainclouds farther east, there came about a half-dozen much smaller objects, of perceptibly discoid form, the Brownings stated. These smaller discs moved much faster than the larger cigar-shaped object, at speeds that Rev. Browning stated to me might have approached jet-aircraft speed. He stressed that these smaller objects "skipped like stones on water," a phraseology that I learned from associates of Rev. Browning did not originate from any previous study of UFO reports, since, prior to that October, 1960 sighting, Rev. Browning not only ignored UFO reports but took a very negative view of the authenticity of most such reports.

The Brownings next saw the discs seem to take up a "formation" around the cigar-shaped object, which had been hovering motionless during the approach and formation of the smaller objects (whose diameter the Brownings guessed at perhaps some tens of feet, in contrast to the perhaps tenfold larger length of the cigar-shaped object). Then, the entire assemblage started moving towards the south, back into the

MAN SOARS OUT...

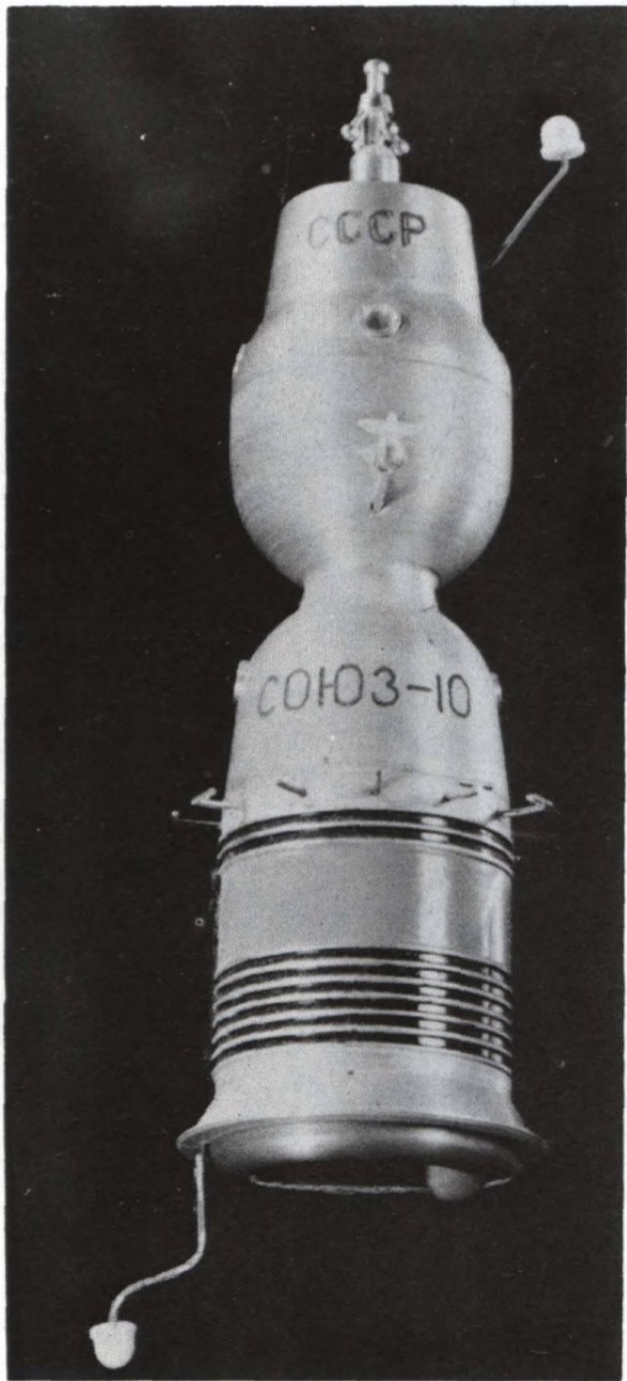
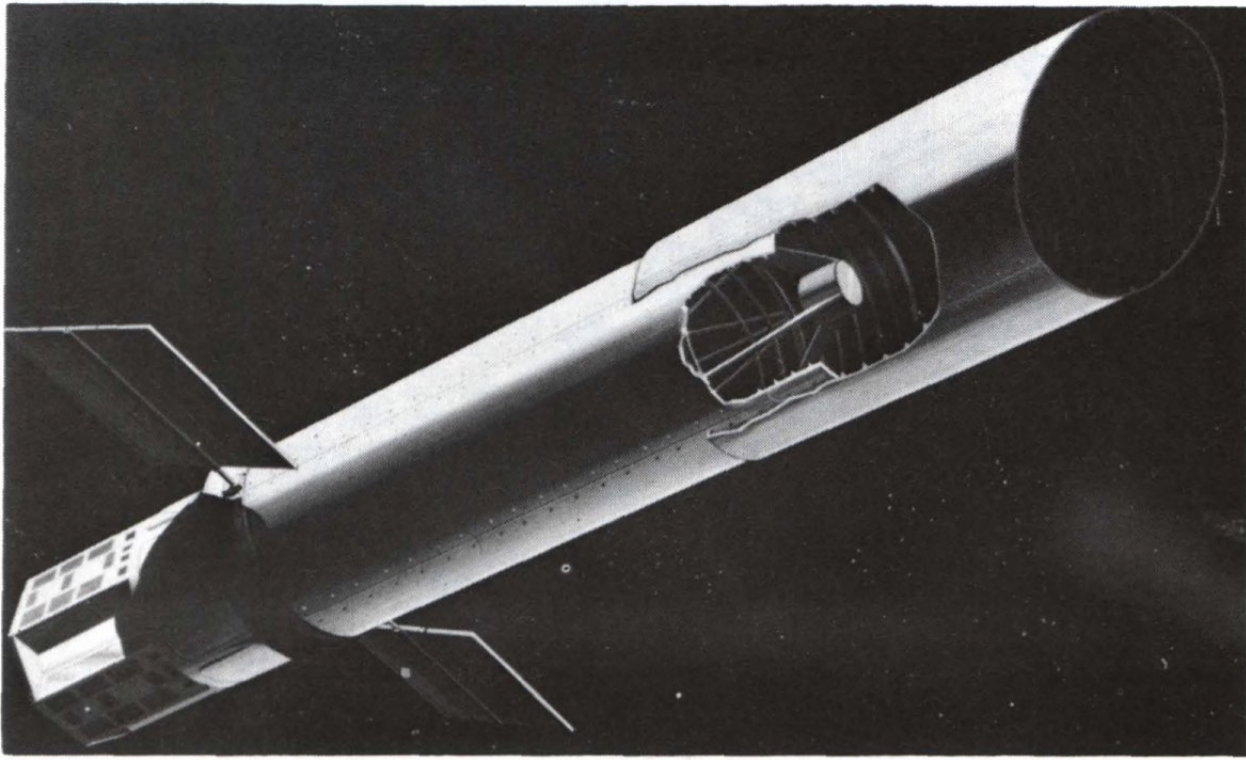

While visits from other civilizations may go back beyond recorded history, man is just starting on course that could enable him to see distant worlds. Large Space Telescope (above), with cutaway showing secondary mirror, is shown as artist's concept while plans proceed for operational launching by space shuttle in 1980's. Unmanned and free-flying, it is first spacecraft designed to be launched and serviced by space shuttle. (Left) U.S. and Russia have agreed to join forces in space study by docking USSR's Soyuz spacecraft, shown here, with U.S. Apollo spacecraft. (Below) Major NASA project is development of space shuttle to be test flown in 1976 and operational before 1980. Smaller craft shown is orbiter portion disengaged from booster portion. Orbiter continues flight while booster begins glide path down to earth landing. (All photos in this feature are from NASA.)

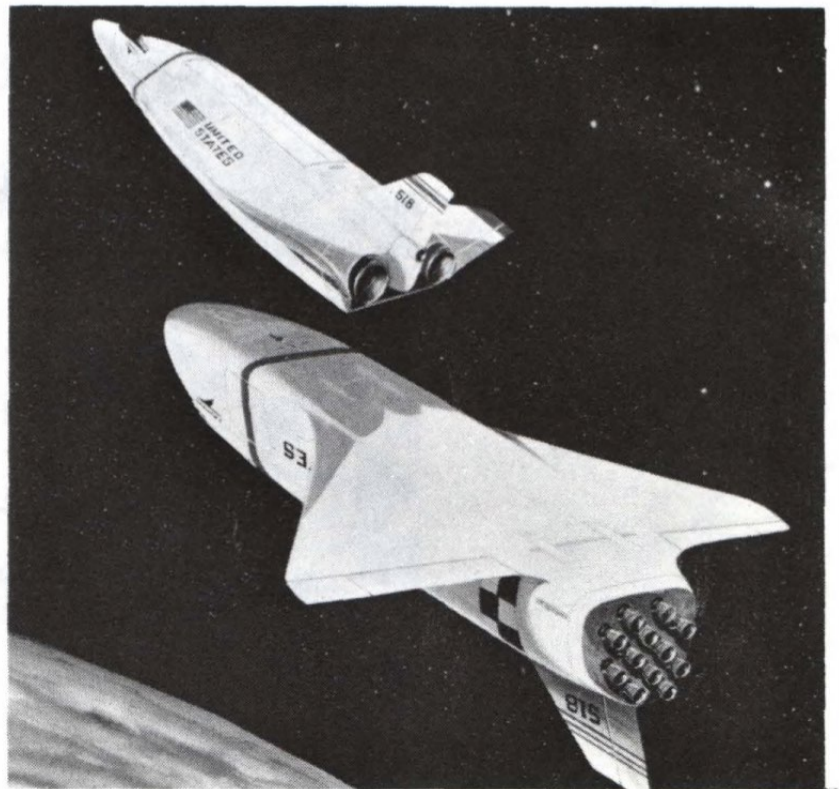

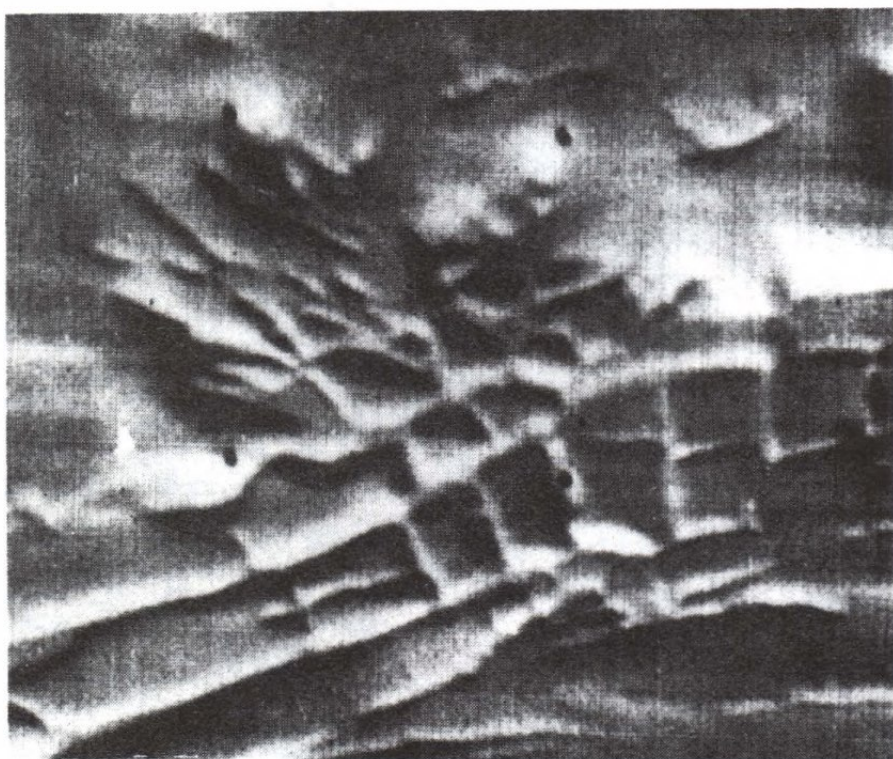
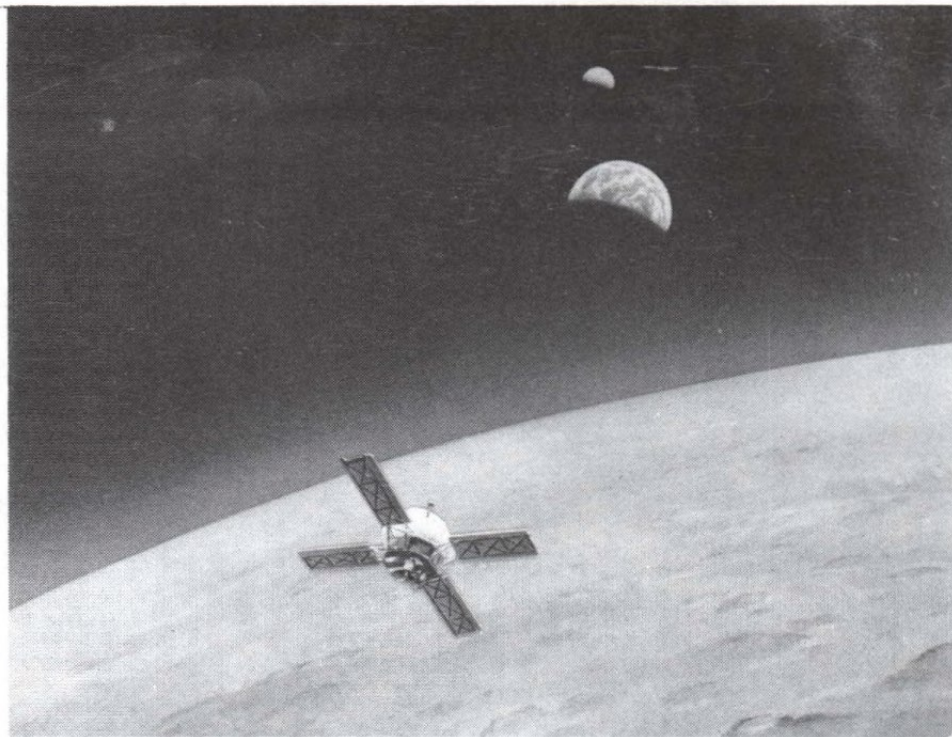

In this drawing (above), Mariner 9 is shown orbiting Mars, with Earth and its moon (much enlarged) in background. Mariner 9 is mapping more than 70 per cent of red planet's surface and studying its temperature, as well as composition and pressure of its atmosphere. Like ruins of ancient city (left) is this strange Martian feature pictured by Mariner 9 from height of 1,821 miles. Ridges, one to three miles apart, are assumed to be veins of wind-resistant material. But considering rarity of right-angle formations in nature, ancient city notion may not be so unlikely after all. Artist's concept (below) of Grumman High Energy Astronomy Observatory (HEAO). Preliminary designs for unmanned observatory indicate it will weigh 20,000 pounds. It will measure 30 feet in length and nine feet in diameter. It will be largest unmanned spacecraft ever launched by NASA.

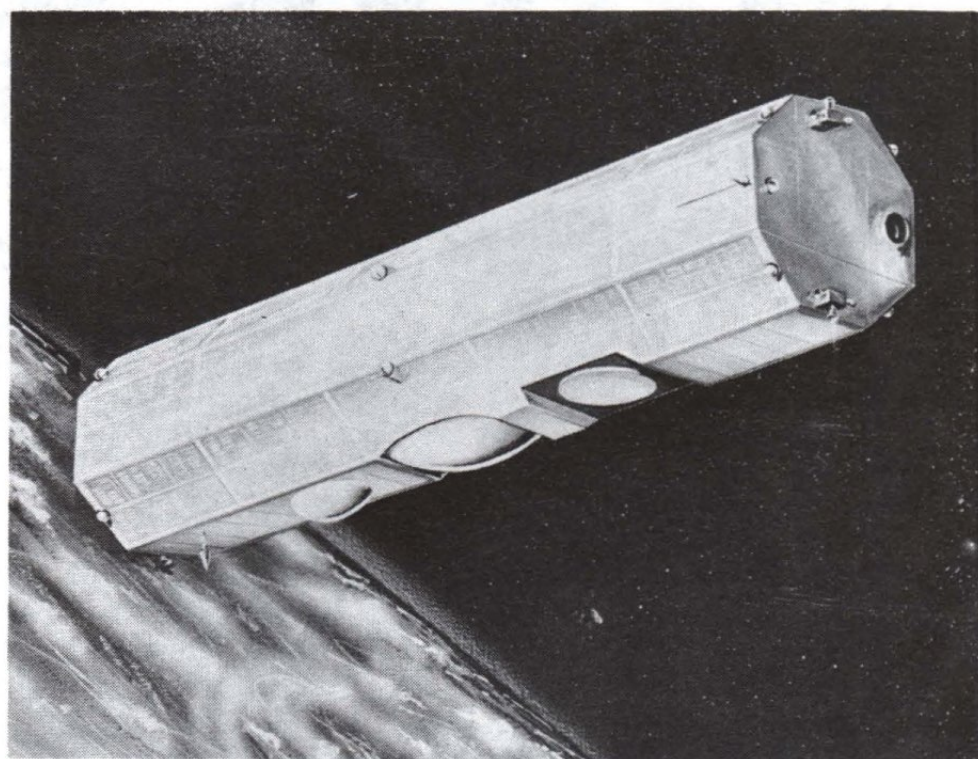

AND BEHOLDS...

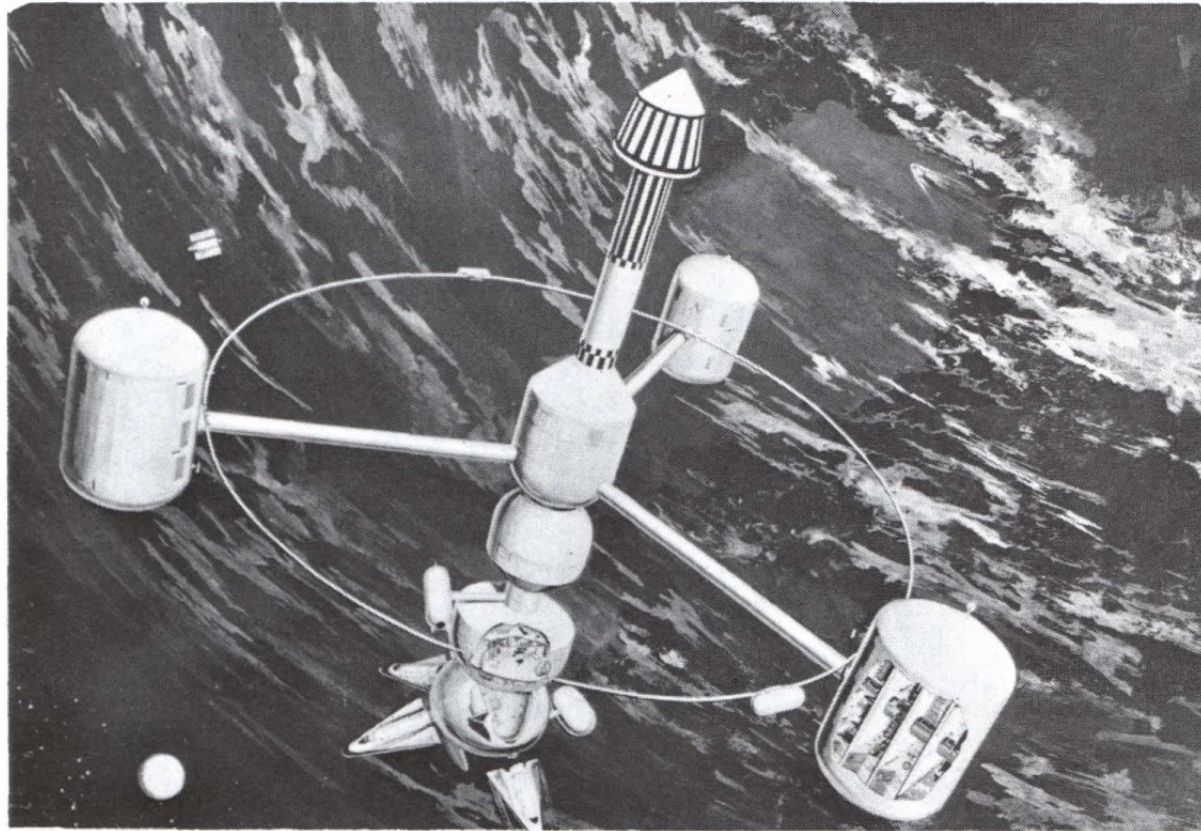

Artist rendering (above) of Grumman space station concept. This version is capable of supporting 50 to 100 people for long periods. Artificial gravity is maintained by centrifugal force in 33-foot modules out on 'arms.' Trolley track vehicles provide transportation between modules. At bottom of station, space shuttle vehicles can be seen in docked position. Astronaut Charles M. Duke Jr. (right), lunar module pilot of Apollo 16 lunar landing mission, collects rock samples during lunar surface activity at Descartes landing site. Picture taken by crew commander John W. Young. Parked lunar roving vehicle is in background. Note crater at left. Jupiter-bound Pioneer 10 (below), having just crossed orbit of Mars, has entered space never before visited by spacecraft from Earth. About July 1 it will reach asteroid belt and will take seven months to cross this 175 million-mile wide belt of rock fragments and cosmic rubble between orbits of Mars and Jupiter. Jupiter is 1,000 times as large as earth and has its own energy source. (All photos from NASA)

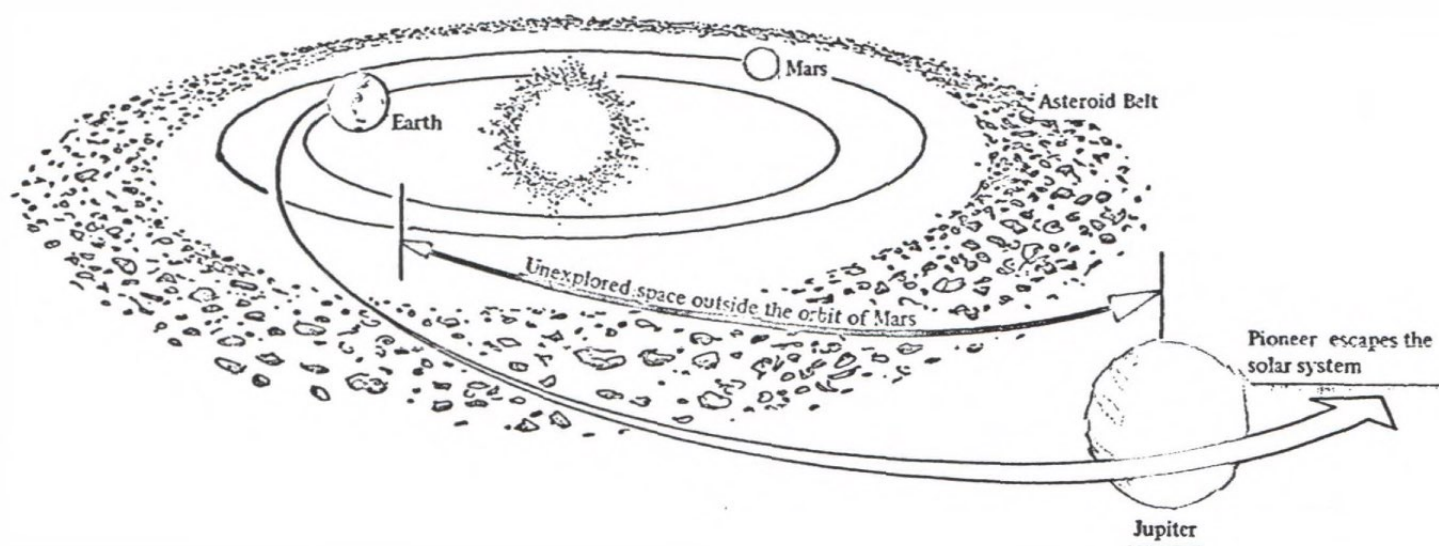
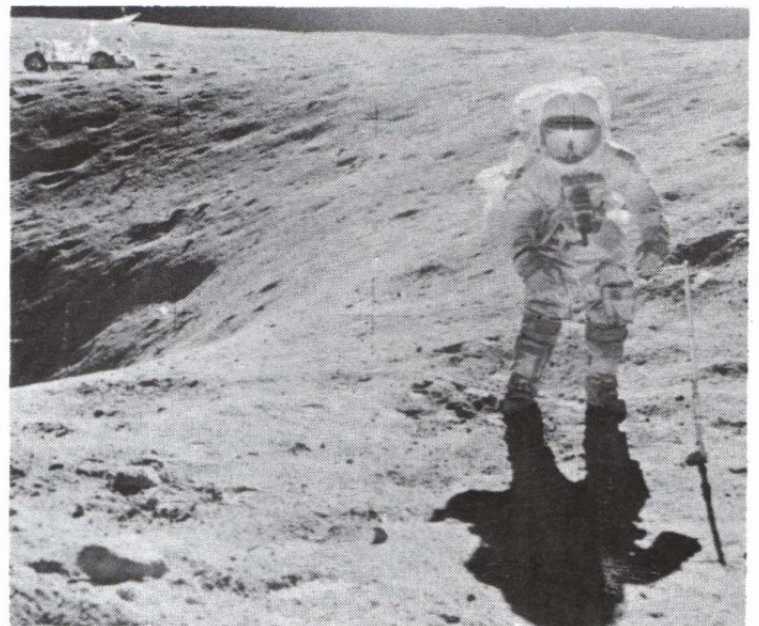

STRANGE SIGHTS...

Earth (right), photographed in far-ultra-violet light by Appolo 16 commander John Young, looks like spaceship it really is. High-level aurorae are visible on night-side. One strong patch is over south magnetic pole (lower cusp), and equatorial belt predicted from other spacecraft can be seen all around night side. Another auroral belt, inclined 30 degrees to equator, is as yet unexplained. Dune field of loose material (below) was pictured by Mariner 9 in floor of 93-mile wide crater in Hellespontus region of Mars. Dune field appears as black spot in wide-angle photo of crater (arrow). Dunes are about one mile apart, and similarity of size and direction indicates they were formed by strong winds blowing from consistent angle.

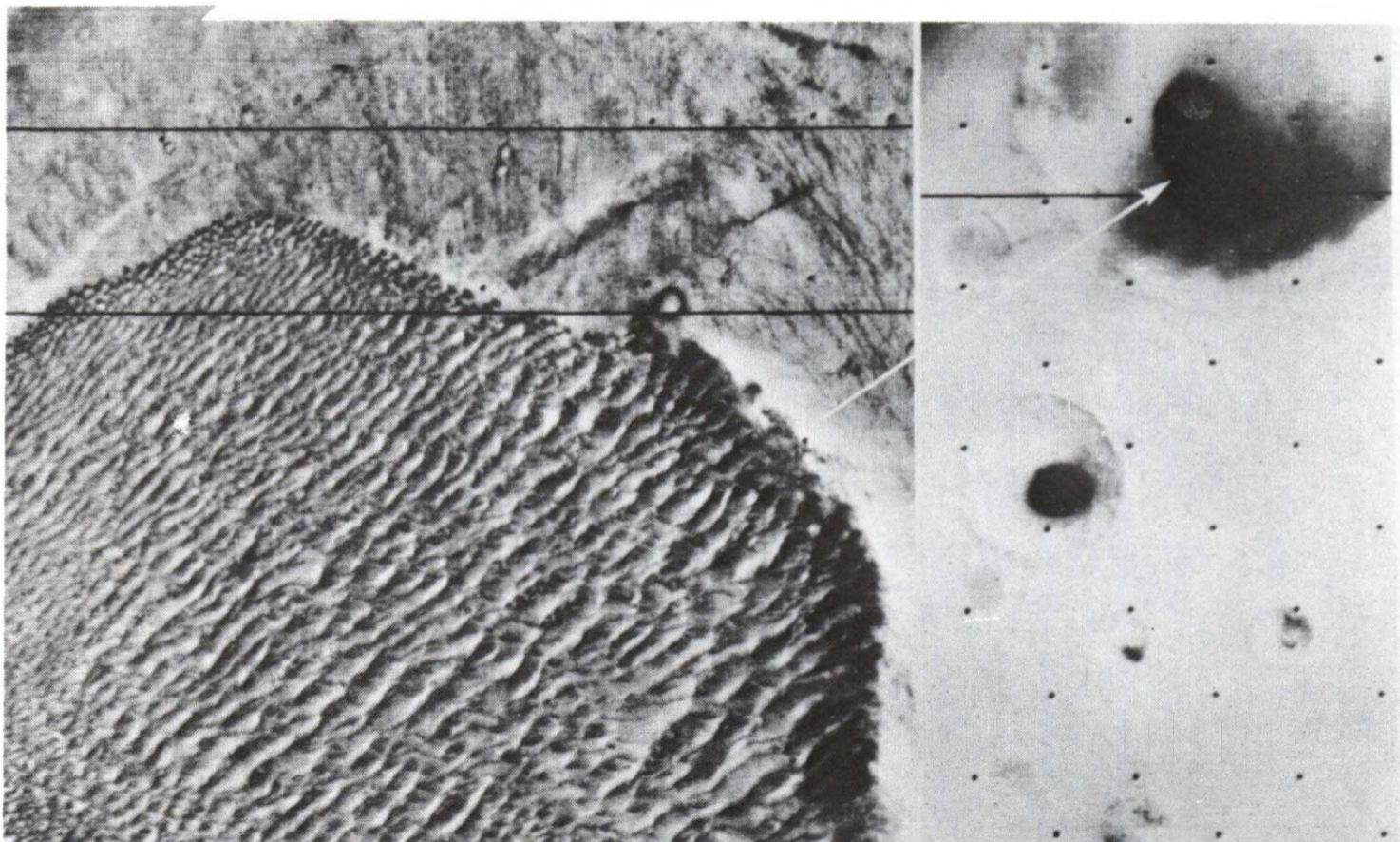

rainshower out of which the large object had first been seen emerging, whence the group was lost from sight, terminating the observation after a total elapsed time estimated by the witnesses as about two minutes, perhaps as long as three minutes.

These objects were illuminated by the setting sun, and Rev. Browning emphasized to me that there was a distinct difference in tone between the dull gray of the larger object and the shiny, metallic luster of the smaller disc-like objects.

The Brownings, after a brief discussion of this event (which by then they construed as "some Russian devices"), called the nearby airdrome to report it, which ultimately brought it to the attention of the RAAF. I have recently had a letter from the RAAF officer who did the interrogation of the Brownings. Wg. Cmdr. G. L. Waller states in his communication that the Brownings "impressed me as being mature, stable, and mentally alert individuals who had no cause or desire to see objects in the sky other than objects of definite form and substance." That impression is attested to by many others who know the Brownings personally, as I established by direct queries in Hobart and Melbourne last year.

My questions as to the ultimate public explanation which the RAAF put on the sighting elicited somewhat bitter comment from Rev. Browning, comment that I later found elaborated in press clippings made available to me by the officers of a very creditable private UFO group in Melbourne (Victorian Flying Saucer Research Society). The Directorate of Air Force Intelligence, RAAF, made official explanation early in 1961: "The phenomena was the result of the moonrise associated with meteorological conditions at the time of the sighting. On 4th October, 1960, moonrise (full quarter) at Cressy would have been visible shortly after 1800 hours and in an ESE direction. The objects apparently seen were near the sky-line in an easterly direction. The presence of "scud" type clouds, moving in varying directions due to turbulence in and around the rain squall near which the objects were sighted, and the position of the moon or its reflections, produced the impression of flying objects."

Such an "explanation" has a curiously familiar ring to anyone who has studied large numbers of USAF "explanations" of UFO sightings. One can quickly establish that the moon was full on the date of the Cressy sighting and that it would have risen not in the ESE but a few degrees north of east. And, still worse for the official explanation, there was not only a dense rain storm obscuring all the eastern sky as seen from the Cressy rectory, but the highest mountain range of Tasmania lay behind those dense clouds to further obscure the just-rising full moon. (Ben Lomond, summit 6160 ft, lies to ENE of Cressy, and the ridges extend off to south and north from that summit point.) From my own viewpoint, as one interested in atmospheric optics and in unusual refractive and reflective anomalies, the official suggestion that "scud" subject to turbulent motions could (had the moon not been wholly obscured by rain and mountain) be optically distorted into anything remotely resembling the phenomena reported by the Brownings seems entirely out of question. (Because USAF explanations have many times asserted, as has also Dr. D. H. Menzel in his writings on UFOs, that the sun and the moon can be "reflected" off sides or tops of clouds, it may be well to state that nothing in decades of meteorological optical observations supports such a notion, save for the phenomenon of the "undersun", which involves specular reflection off tabular ice crystals falling in completely *non-turbulent* air, and visible only from an aircraft or elevated vantage point. Sun and moon do not yield anything like distinct images by reflection off the walls of clouds; all UFO explanations invoking such optical absurdities are unreasonable. It might be added that Menzel has repeatedly erred in referring to sundogs, i.e., parhelia, as resulting from "reflection", since that familiar optical effect is caused by ice-crystal refraction.) In asserting such a meteorological explanation as was issued by the RAAF intelligence office, little evidence of scientific knowledge

was exhibited, unless that office felt that the essential features of the Brownings' account had to be simply disregarded as unreliable. Yet the interrogating RAAF officer, Wg. Cdr. Waller, evidently had no such inclination to disregard these witnesses' description of their observations, nor do I.

Case 3. Fukuoka, Japan, October 15, 1948

From Air Force Project Bluebook files comes the material summarized here for this officially UNIDENTIFIED case involving airborne-radar and air-visual observation of an unconventional "bullet-shaped" object. At 11:05 p.m. LST, a USAF F-61 Black Widow fighter, with crew of pilot and radar observer, flying near Fukuoka, obtained a radar pickup on an unknown target at an altitude of around 6000 ft, and an initial range of about 10 miles. The total encounter, occupying a period of about ten minutes, is too complex to describe in full detail here. The Bluebook file on it, about a quarter-inch thick, contains a number of different intelligence reports that are not mutually compatible on certain quantitative details (closure distances, etc.). Briefly, a total of six radar passes were made, and each time the F-61 closed to about 4000 yards, whereupon the unknown accelerated suddenly from about 200 mph to an estimated 1200 mph. The original report from Far East Air Forces intelligence sources states that the unknown "had a high rate of acceleration and could go almost straight up or down out of radar elevation limits. . . There was sufficient moonlight to permit a silhouette to be discerned although no details were observed." The F-61 crew thought it possible that the six passes might have been made on two separate unknowns, but this was inferential.

Another portion of the official file includes a FEAF followup report, describing some other points: "When the F-61 approached within 12,000 ft the target executed a 180° turn and dived under the F-61. The F-61 attempted to dive with the target but was unable to keep pace. . . It is believed that the object was not lost from the scope due to normal skip null-zones common to all radar equipment. The pilot and observer feel that it was the high rate of speed of the object which enabled it to disappear so rapidly." And still another document in the Bluebook file on this UNIDENTIFIED describes the visual sighting made at one juncture: "At time of only visual sighting target was on a level with observing aircraft. Under night visibility all that was visible was a silhouette. Type of tail stabilizers is unknown. General classification — very short body giving a stubby appearance. Canopy, if present, was formed into aircraft body to give the object cleancut lines and was not discernible." The estimated size was 20-30 feet, and an accompanying sketch shows it as having a sharply cut-off tail ("bullet-shaped"). No exhaust was seen. The moon was nearly full on that night, and the airmen saw the outline against a moonlit cloud, they stated in their report, USAF ground-radar stations at Shigamo-Shima and Fukae-Shima had the F-61 on their scopes intermittently as it moved in and out of ground clutter, but at no times obtained a radar-return from the unknown.

Ruppelt (E. J. Ruppelt 'Report on the Unidentified Flying Objects') states that the Fukuoka sighting was one of the first UFO cases where an UNIDENTIFIED was seen on a radarscope; but many have since attained that distinction. Indeed, when one reads the full text of the 1953 Robertson Panel, one of the arresting points is the evident concern with the large number of "radar fast-tracks" already on record by that date. Despite the existence in USAF records of a number of UNIDENTIFIEDS seen on radar (often with both airborne and ground radar and sometimes also with ground- and air-visual sightings in accord), members of a Congressional Armed Services Committee investigation, inquiring into the UFO problem after the 1966 Michigan "swamp gas" episode, were told on April 5, 1966, by the USAF Bluebook officer, "We have no radar cases which are unexplained," when Congressman Schweiker raised that

pertinent question.

Case 4. Gulf of Mexico, December 6, 1952

Just to cite briefly another example of a radar-visual sighting in the official UNIDENTIFIED category, one might mention the December 6, 1952 air-borne sighting by the crew of an Air Force B-29 flying over the Gulf of Mexico at 18000 ft in bright moonlight. (See 7 for further details.) A total of over a half-dozen separate unknowns, seen on the B-29 radarscopes and by crewmen watching out side-blinders, passed at high speed (some speeds roughly estimated at 5000 mph from blip displacements). Some of them were seen *below* the flight altitude, and others maneuvered in most unconventional patterns (sudden course-reversals). No meteor explanation would fit the visual sightings, and ground-return effects are essentially out of the question by virtue of the high altitude and by the features of the atmospheric lapse rate at the time and area of the unusual sighting. It remains an UNIDENTIFIED in USAF files.

Case 5. Washington National Airport, July 19 and 26, 1952

Many more Bluebook file reports that are in the "explained" category also involve radar-tracking of intriguing nature, but have been tagged with a variety of other identifications. One of the most famous is the 1952 episode near Washington National Airport (July 19 and 26, 1952). I shall not give an account of it here (see for example Ruppelt), but only remark that my own analysis of the radiosonde data for those two nights leads me to diametrically opposite conclusions from those that have remained the official views for fifteen years. There were only very weak inversions and moisture gradients present on those nights, incapable of causing the striking radar and visual effects reliably reported. I have recently interviewed five of the CAA controllers and four pilots involved in that sighting and can only say that it is a case of extremely great interest — fully deserving the national-headline treatment it got in 1952.

Further measure of the limited knowledge of the actual history of UFO investigations held by the USAF personnel charged with UFO responsibilities can be found in the same April 5, 1966 testimony previously cited. (See H.D. 55, Hearing by Committee on Armed Services, HR, 89th Congress, 2d Session, 4/5/66, p. 6075). Congressman Stratton asked Bluebook Officer Quintanilla: "Was there not a sighting, back it seems to me in 1947, when an object was observed on radar, either at National Airport or Bolling, both coming in and going out? It seems to me there was also a visual sighting that went along with that. . . Is this in your records at all?" Now, almost anyone who had attempted a serious study of UFO history would immediately recognize that Mr. Stratton, albeit confused about his recollected details, was asking of the famous Washington National sightings of July, 1952. Yet the incumbent Bluebook officer replied, "I am sure that if the sighting was reported to the Air Force it is on record, but I am not aware of this particular one, sir."

It is, I fear, such casual failure to really close with the puzzling nature of the UFO problem that has left it in limbo for twenty years. And all of that time, Pentagon press statements gave repeated assurances that real expertise was at work proving the correctness of the Air Force position as to misidentified natural phenomena. It is a very distressing and a very unbelievable story, which is only faintly hinted by the brief remarks that can be made here. But from the point of view of deserved international scientific attention to the UFO problem, candid criticisms of the USAF handling of this problem seems necessary to make clear that there has never been any in-depth UFO study within the U.S. Hence, I now wish to put myself on record once again as characterizing most of the past 15 years of Bluebook work as scientifically incompetent and superficial. Yet it has done the trick: it has kept all of us unconcerned about the UFO problem.

Conspiracy? No, not as I see it, Foulup.

Case 6. Near Barcelona, Spain, September 10, 1967.

Over the past twenty years, airline pilots and flight crews have been a continuing source of scientifically puzzling UFO reports. One of the earliest, still carried by Bluebook as one of its UNIDENTIFIEDS, is a July 4, 1947 UAL sighting near Boise. When some months ago I interviewed Capt. E. J. Smith, pilot of the DC-3 from which the sighting was made at sunset, shortly after takeoff, his opinion that the two formations of disc-like objects that he, his co-pilot, and a stewardess had seen 20 years earlier were no conventional aircraft seemed as strong as it had been when he was interviewed by reporters in 1947. From Capt. Smith's sighting down to the present, the class of airline-pilot reports has remained a most important class because of obvious observer-credibility factors. Let me recapitulate a much more recent one.

Just before sunset on September 10, 1967, four crew members of an Air Ferry Ltd. DC-6, bound for England from Majorca, sighted an unconventional airborne object about 60 miles NW of Barcelona, at 16,000 ft. A brief report appeared in the Sept. 11 edition of the London *Daily Express*, independent British investigators assembled further information, and one of the crew, F/L Brian Dunlop, submitted a summary account to VFON headquarters (Volunteer Flight Officers Network, a clearing-house in Denver for meteor, vehicle-reentry, and other aerial-sighting reports).

When first sighted, according to Dunlop, the unknown was about 30° to the left of their northbound flight path, heading towards the west at an altitude slightly above theirs. Its initial estimated distance was put at a number of tens of miles as it crossed to their right, turned towards them, and then approached after an apparent deceleration and a descending motion. The shape of the metallic-appearing object resembled an inverted ice cream cone, with a rounded base and pointed top. Dunlop stated, "There was a definite solid object the like of which none of the four crew that saw it had ever seen before, and we had been quick enough we could have got a good photo of it." Capt. F. E. C. Underhill stated in another interview that the UFO "must have been under control. . . it definitely altered course substantially." The course alteration brought it on a head-on approach, but it passed *under* the DC-6's starboard wing and disappeared to their south. The crew did not alert any of the 96 passengers aboard in the total viewing time of about 2-3 minutes, not wishing to alarm them. Estimated speed of the object was 600-700 knots, whereas the ambient wind at flight level was only 10 knots from the north. A check with Barcelona flight controllers indicated there were no known aircraft in the area, but reports do not indicate if radar coverage was available.

The shape, the veering path, the passage under the aircraft's flight level all rule out meteoric phenomena. That it was not a balloon was indicated not only by the shape, but its reported motions do not match balloon behavior in any obvious way. It would seem to be one more airline-reported unidentified flying object.

Case 7. Peruvian coast, December 30, 1966

South America has been a source of extremely large numbers of UFO reports. I have never been in a good position to evaluate the credibility and credentials of witnesses in these reports and hence pass no present judgment on most of them, but stress that they warrant searching study. One rather interesting case that has been cross-checked sufficiently to appear well authenticated involves observations by the 6-man flight-crew of a Canadian-Pacific Airlines DC-8, who sighted an unconventionally behaving airborne object over the Peruvian coast as they headed northwest at 35,000 ft. altitude on the indicated date early in the morning (0300 LST). A report to VFON, and other reports in the press and elsewhere, give salient features of the event.

Capt. Robert Millbank's report stated that the unknown was

first spotted 70° to the left of their flight path, at an estimated elevation angle of about 10°. There was a clear sky, with stars visible. At first detection, the unknown seemed to consist of a pair of lights of high luminosity, hovering for perhaps a minute, and pulsating. It next moved down towards the plane, and assumed a position off their left wing, seeming to pace the DC-8 for another minute or two.

All six crewmen took turns looking at the unknown through various windows to be positive that window-reflection effects were not involved. As the unknown paced the aircraft, it appeared to be a pair of bright lights, separated by 3-4°, and with some vaguely perceptible structure joining the lights, according to some of the crew's accounts. Others felt that no interconnecting structure was discernible, in the estimated 1-2 minutes that the object lay off the port wing (at a distance that could not be reliably estimated, but was felt to be of the order of perhaps a mile). A V-shaped pair of thin light beams emanated from the object, pointing upwards initially, but downwards later, according to Millbank's account. All passengers were asleep, and no photographs were made.

Millbank stated that "in 26 years of flying I have never seen anything like this before." Second Officer J. D. Dahl said, "... in my opinion, the only answer to this sighting is a craft with speed and controllability unknown to us." Other sighting details will be omitted here. After a few minutes of pacing to the DC-8's port side, the object was seen to accelerate, pull away, and climb rapidly out over the Pacific to the west, where it was lost in the distance.

Here, as in such a disturbingly large number of commercial airline UFO reports that have been ignored or explained away during the past two decades, one is hard put to give any conventional explanation. Clearly, unless one throws out most of the sighting details provided by the six crewmen, it will be quite unreasonable to call this unknown an aircraft, a balloon, a meteor, a plasmoid, an hallucination, or any of the other frequently-invoked mis-identifieds.

Case 8. Corning, California, July 4, 1967

At about 5:15 a.m., PDT, on the morning of July 4, 1967, at least five witnesses (and reportedly others not yet locatable) saw an object of unconventional nature moving over Highway 5 on the edge of Corning, California. Hearing of the event from NICAP, I began searching for the witnesses and eventually telephone-interviewed four. Press accounts from the Corning *Daily Observer* and Oakland *Tribune* afforded further corroboration.

Jay Munger, operator of an all-night bowling alley, was drinking coffee with two police officers, James Overton of the Corning force and Frank Rakes of the Orland force, when Munger suddenly spotted the object out the front windows of his bowling alley. In a moment all three were outside observing what they each described as a dark gray oval or disc-shaped object with a bright light shining upwards on its top and a dimmer light shining downward from the underside. A dark gray or black band encircled the mid-section of the object. When first sighted, it lay almost due west, at a distance that they estimated at a quarter of a mile (later substantiated by independent witnesses viewing it at right angles to the line of sight of the trio at the bowling alley). It was barely moving, and seemed to be only a few hundred feet above terrain. The dawn light illuminated the object, but not so brightly as to obscure the two lights on top and bottom, they stated.

Munger, thinking to get an independent observation from a different part of Corning, returned almost immediately to telephone his wife; but she never saw it for reasons of tree-obscuration. At my request, Munger re-enacted the telephoning process to form a rough estimate of elapsed time. He obtained a time of 1-1.5 minutes. This time is of interest

because, when he completed the call and rejoined Overton and Rakes, the object had still moved only a short distance south on Highway 5 (about a quarter of a mile perhaps), but then quickly accelerated and passed off to the south, going out of their sight in only about 10 seconds, far to their south.

Many skeptics reasonably enough ask why there are not many good photographs of UFOs. This is a difficult question to answer; certainly it is true that when hoax photos or dubious photos are excluded, one seems to have left a dismayingly small number of good UFO photos after 20 years of UFO sightings. A factor that may often be involved is that even those witnesses who do have loaded cameras nearby may not recover from their surprise before the object is gone. Officer Overton stated to me in my telephone interview that he had binoculars and a loaded camera in his patrol car, only a few tens of feet from the parking-lot spot where he stood gazing at the object, yet he was so stunned by the unprecedented nature of what he was seeing that it never occurred to him to run for his camera. Munger's phoning-time check suggests that this failure to think of his camera lasted over an interval of about a minute and a half.

Paul Heideman, of Fremont, California, was driving south on Highway 5 at the time of the above sighting, along with a friend, Robert King. I located Heideman and obtained from him an account of his observation made from a point on the highway north of Corning. He saw the light from the object, and had it in sight for an estimated three minutes, as it headed south, and then veered east (a turn not seen from the more restricted viewing point of the bowling-alley parking lot). Heideman said that, when first seen, it lay almost straight down Highway 5, serving to check the estimate of the other observers that the object lay only a few city blocks to their west.

The weather was clear, no haze, no wind, according to the witnesses. Munger's concise comment was, "I've never seen anything like it before." He estimated its "diameter" at perhaps 50-100 ft, and its vertical thickness as perhaps 15-20 ft, with some kind of edge (band) perhaps 5-10 ft thick. No sound was ever heard. Overton stated to me that he had no idea what it was, but that "there was no doubt it was a craft of some sort."

Here one has a daylight sighting by at least five witnesses from two viewing points, lasting for many tens of seconds. The object exhibits opacity plus light-sources. Its motion varies from near-hovering to high speed. It is seen over an azimuthal range of almost 90° by the three observers who got the closest look, yet no wings or empennage is seen. What is it? Lack of sound at as close a range as a quarter-mile and in the quiet of the early morning in a small town rules out a helicopter; lack of wings rules out a conventional aircraft. Balloons, meteors, meteorological-optical effects, and the rest of the constellation of frequently-invoked explanations do not appear to fit such a sighting. It appears necessary to describe the object as an unconventional machine-like object — or reject the witness' testimony. The scientifically embarrassing point here is that *many* other such hard-to-explain observations of machine-like objects are not on record — and being ignored.

Case 9. Kansas City, Kansas, August 12, 1961

Another such case, involving very much closer-range observation of a craft-like object, is to be found in Bluebook files as an UNIDENTIFIED. (USAF has repeatedly asserted, for 15 years, that in their unidentified cases lies nothing that defies explanation "in terms of present-day science and technology." *Not so*, I am obliged to say. I am making a special study of Air Force UNIDENTIFIEDS, and would stress that there is a very large body of phenomenology in those UNIDENTIFIEDS that most certainly defies explanation in terms of today's science or today's technology! Indeed, this is the principal conclusion of the studies of all serious students of the UFO problem.)

At about 9:00 p.m. on August 12, 1961, two college-age

boys living in Kansas City, Kansas, became involved in a close-range sighting of considerable interest. I have recently interviewed both of these witnesses, T. A. Phipps and J. B. Furkenhoff. They were driving towards Furkenhoff's home in Phipps' open-top convertible near Old Mission High School on 50th Street. Furkenhoff sighted the object first and had been watching it for some time before he called it to Phipps' attention. It seemed to be hovering, by that time, at perhaps 50-100 ft altitude over a point only a few city blocks away. It appeared to have lights all around its lower edge, and made no sound then or later.

They drove almost directly under it and looked up at its base, where it hovered over houses whose residents were evidently unaware of the presence of the object, since no other persons were seen out of doors by the two boys. No wings, tail or propellers were visible, and no exhaust or noise was perceptible. The lights around its underside were yellowish and had a neon-glow character, according to Phipps. It was the complete lack of sound that eventually made them uneasy after a total viewing-time that they estimated at several minutes. They did not get out of the convertible, from which they had a quite adequate view. Phipps could not recall whether he stopped his engine.

The size was estimated as that of "a football field" when they were interrogated by USAF personnel in 1961 (Bluebook file account), but when I interviewed them in early 1968, they put it at more like 100 ft across. It was opaque, solid, and obscured the sky above, which was cloudless according to the Bluebook data. The Bluebook file report indicated that its shape was compared to that of a "sled with running boards", yet neither witness, when I questioned them, had the slightest idea how such a description was filed by the interrogating personnel. Their recollections differed as to shape: Phipps recalled it as disc-shaped, while Furkenhoff recalled it as a rounded cylinder.

After about 3-4 minutes of observing the silently hovering object, their uneasiness was broken by the sudden departure of the object. It accelerated from a stationary position and climbed away out of sight in a time of only a few seconds, each witness agreed. The precise climb-out path was recalled somewhat differently by the two witnesses. The 1961 Air Force interview recorded the climb-out as beginning with a directly vertical ascent followed by an inclined departure path to the east.

They each told their parents, and Phipps' mother asked a friend who was on active Air Force duty, a Maj. John Yancer, to phone the Richards-Gebaur AFB near Kansas City. He was told that an unidentified had been seen on radar, and so he urged that the boys be interviewed by USAF personnel. Telephone interviews were accomplished the next day, but no further USAF interrogation in the ensuing half-dozen years was ever carried out. This, despite the fact that it was put in the UNIDENTIFIED category at Bluebook. Such lack of followup of even the most intriguing UNIDENTIFIED cases is almost the rule, not the exception; this systematic failure to pursue UFO reports is only one of many disturbing facets of the USAF investigations since 1953.

The August 1961 sighting is not readily explained. Economy of expression suggests calling the object an unconventional machine-like object exhibiting performance characteristics well beyond the state of the art. I must say it also seems to defy explanation in terms of present-day science and technology, to use the Air Force's threadbare phraseology.

Case 10, Moe, Australia, February 15, 1963

To maintain a certain international tone, in keeping with the title of my remarks, I close with another interesting sighting made in a distant area. With the aid of the Melbourne VFSRS group, I was able to interview Australian farmer Charles Brew and his son Trevor last summer. They operate a small dairy farm east of Melbourne, near Moe, Vic. My interview was carried out

in the milking shed where Brew and his son were working at about 7:00 a.m. on Feb. 15, 1963 when an unusual object swooped down nearby.

It was already light on this summer morning, although rainclouds lay overhead. Trevor was working in a part of the milking shed where his view of the eastern sky was obscured and he did not see the object during its short-duration passage nearby. Charles Brew, however, was standing in an opening, with a full view to the eastern sky when the object descended towards his shed and cattle-pens at an angle that he put at about 45°. The object might be loosely described as a domed disc, estimated by Brew at 25 ft in diameter, gray in color except for a transparent dome on top. Around the circumference of the object he saw an array of scoop-like or bucket-like vanes or protuberances.

As the object swooped down, almost as if to land on the hillside nearby, the cattle and horses reacted in violent panic which Brew described (in his own terms) as unprecedented. It descended to an altitude that he judged to be 75-100 feet, as estimated by the height of a tree near its point of minimal altitude. Then, after seeming to hover near the tree for a few seconds, it began a climb at roughly 45°, continuing on its westward course and passing up into the cloud deck again.

The dome was not rotating, but the central section and bottom portion appeared to be rotating at about once per second, Brew judged. The spinning motion caused the protuberances (Brew thought) to generate the swishing noise, somewhat like a turbine noise, that was clearly audible not only to Brew but also to Trevor, located inside the shed and not far from a Diesel unit powering the milking machines. The sound was even audible over the latter local noise-sources, Trevor stated.

It took some time to recover the animals that had bolted, and those already inside the fenced area were strongly disturbed for some time. Brew stated to me that it was many days before any of his cattle would walk over the part of the hillside pasture over which the object had momentarily hovered. Brew himself reported an uncommon headache persisting for a number of hours after the incident, but whether this was fortuitous cannot be concluded.

Brew has been interviewed many times by Australian UFO investigators without any reasons being found to discount his unusual sighting. My reaction to Brew was similar. It is unfortunate that the son was not in position to confirm the sighting, but he confirms the unusual sound ("like a diggerdoo", as Brew put it). The object is similar in its general features and size to that seen by a witness I interviewed in New Zealand, Mrs. Eileen Moreland. Her July 13, 1959 observation, like Brew's, and like that of many other UFO witnesses, is extremely difficult to explain in present-day scientific or technological terms.

The foregoing constitute ten UFO cases from fairly widely ranging geographical areas, and spanning almost two decades of time. They are intended to be illustrative but not "representative", since one of the baffling features of UFO reports (easily scoffed out of court by the skeptic) is the remarkable variety of shapes, sizes, and maneuvers reported. No mere sample of ten cases can give any feeling for that puzzling range of UFO phenomenology. Nor can a mere ten cases out of the thousands that are now on record in official or unofficial files convince a properly skeptical scientist that we are dealing here with extraterrestrial surveillance (the hypothesis that my studies suggest as most likely). One must carefully examine not tens but hundreds of such reports before the weight of evidence is seen in some perspective. The difficulty has been that very few scientists have carried out such examination to date, and hence the low *a priori* probability of extra-terrestrial surveillance leads most scientists to discount such a possibility.

Hence, the above ten illustrative cases are only intended to convey a general impression of the puzzlement that inheres in so

most certainly not convinced by the first ten good cases I had checked. But I was quite intrigued, and hence kept checking. Many more scientists must do the same and add the weight of their opinion pro and con the extraterrestrial hypothesis.

many UFO reports, to suggest that possibly we do have here a problem of considerable scientific interest. In my own opinion, the UFO problem may be the greatest scientific problem of our times; but I do not expect ten cases to convince doubters. I was

FLYING BLOCKS OF ICE

by

Michael Hervey F.I.A.L., B.E.M.

The term "Peripheral Ufology", coined by the editor of UFO Register, J.B. Delair, covers the more bizarre and unexplained events related to outer space. As, for instance, the blocks of ice that have mysteriously descended out of a clear blue sky from time to time.

Meteorological and aeronautical scientists in Britain are still puzzling over a strange phenomenon that occurred late in 1950 when a shower of big ice blocks crashed from the sky over various parts of Britain.

Many theories have been advanced and investigated, including one that the icy missiles were a bombardment from another planet. It was suggested that the missiles were launched from flying saucers, reports of which were particularly prevalent at the time. Whatever the theories and conjectures, there is no doubt about the facts.

During November and December, 1950, at least 12 cases were reported of these missiles, which ranged from a foot to a yard across, and weighed from a few pounds to several hundred.

One block of ice about a foot wide landed at Loudwater, near High Sycombe, in Buckinghamshire. The same day another crashed down at Vigo Village, Gravesend, Kent. A few days later another chunk of ice fell from the sky in London, near Tooting Broadway, striking a woman on the head as she was alighting from a tramcar. She happened to be wearing a thick scarf around her head which cushioned the impact, and she escaped serious injury.

A much larger piece crashed to the accompaniment of a noise like an explosion, through the roof of a garage belonging to Messrs. Fisher and Stacey, at Wandsworth, London. It made a hole in the roof more than two feet long, and narrowly missed a number of employees who were at work below. The ice in this case, according to the report, had a brown hue.

On November 9, blocks of ice weighing over 14 pounds were found scattered over a wide area of Exmoor. One of them had killed a sheep. Three days later a lump more than 12 inches long landed on the grass verge of a roadway

uncomfortably close to a Royal Automobile Club patrolman, D. Trunmore, at Braughing in Hertfordshire. He stopped a number of passing motorists to show them the frozen mass.

A Mr. Butcher, living at The Downs, Stebbing, near Dunmow, Essex, found outside his own door a large piece of peculiar-looking ice, which was later turned over to an Air Ministry inspector.

In quick succession reports came in from Chelmsford and Wandsworth of further similar bombardments from the sky. A huge chunk weighing more than 100 pounds also fell in Ardencaple Drive, Helensburgh, Dumbarton, Scotland, scattering jagged splinters of ice in all directions. Daird Patterson, who resided in the neighbourhood, was struck by one of the splinters.

All these strange incidents were investigated by the police and by meteorological experts. They established that the weather conditions prevailing at the time were not conducive to the formation of abnormally large hailstones.

An Air Ministry explanation was that the ice must have fallen from aeroplanes. It was suggested that water draining from a wash-basin in an airliner normally disappeared as spray, but in freezing conditions it was possible for it to form ice on the underside of the fuselage. If the plane then flew into a layer of warmer air, the ice might loosen and fall.

A weakness of that explanation was why hadn't blocks of ice descended from the skies in previous years, and also why should they only have dropped over the British Isles?

The matter was raised in the House of Commons toward the end of December by Sir John Mellor. The Parliamentary Secretary to the Ministry of Civil Aviation admitted no proof had been found for the assumption that the water outlet of aeroplanes was the cause of the blocks of ice falling from the sky.

The real explanation of this icy bombardment from above is still a mystery. True, many strange objects have fallen from the sky in various parts

of the world through the ages—frogs and fishes, for instance—and even reptiles. It has even rained blood and red snow.

In Limerick and Tipperary there were showers of a soft, fatty substance that resembled butter, which was of a dark yellow colour, and always fell at night.

Perhaps the most puzzling of all such fallout, however, was the strange food that fell from heaven in Biblical times to sustain the Israelites in their journey through the wilderness. What is it, they asked, or in their tongue, man hu? And so mankind came to know of the mystery of manna.

And Now . . .

FLYING ROCKS

An intriguing occurrence in ufology is to come across sighting reports which, though far removed from each other, have certain striking details in common. We have learned of two recent such cases.

One occurred in New Zealand where it was reported by The Christchurch Star of Nov. 1, 1971. Describing how a picture of a strange flying object was taken July 2 by Leslie Farrell, 17, of Toorooka, the Star reported that since April there had been more than 20 UFO sightings in that same region, called the Willi Willi area. It then quoted UFO researcher Frank Wilkes who was interested in young Farrell's experience:

"Les picked up a piece of slag near Willi Willi about 12 months ago. It was in open country and hot when he found it. Other rocks within a foot of it were also hot even though it was early on a winter's morning.

"The slag could not have fallen from a truck and no flying apparatus uses this type of material so there is no good explanation for it being there.

"Chemists in the university laboratory (of the University of Sydney where the specimen was studied) suggested that there are types of material that did heat up when wet, but this experiment was tried without success. We can only assume that the rock was hot when it landed.

"It is a very heterogeneous type of rock — tan-colored with horizontal black streaks of porous material. In fact, the whole piece is very porous and light — too light and too porous to be a meteorite."

At the time of the press report the university had not announced its findings. But the point to be noted at the moment is the description of the rock's light, porous quality.

Now consider this item on the other side of the world in The Daily Mail of Hagerstown, Maryland, June 14, 1971:

"For a while, Armintha Raypole must have thought

the sky was falling at her farm home two miles north of Ill. Rt. 143 on the Millersburg road. A smouldering object was found in her yard around 4 p.m. Thursday (June 10, just 12 days before the N.Z. incident) and about half an hour later more pieces of unidentified material fell from the sky striking her car and landing in a nearby cornfield.

"Just what the material was no one seems to know but it is thought that it might be 'space junk,' unwanted materials jettisoned by man during space exploration.

"Whatever it was it had a definite form after it came to rest in the Raypole yard but it fell apart and began to smoke and pop 'like a firecracker' when it was turned over.

"Enough of it remains to tell that it did have some definite shape and consisted in part of metal. The bulk of what remains is mostly light weight, porous, grey rock-like material.

"A portion of the material was taken to Greenville College where it is currently being examined to determine its make up but as of this morning it is only known that the object did an appreciable amount of radiation if indeed it did fall through the earth's atmosphere.

"To add to the mystery, it was reported Saturday morning that the material began smoking and sizzling again following a rainstorm."

It will be quickly noted there are differences in the two cases — the most obvious being that in Maryland the material heated up when wet and in N.Z. it did not — but the impression remains strong that they concern one and the same thing, the descriptions on at least two counts being identical, and that man-made "space junk" is not a sensible answer.

With metal attached, it would seem it was indeed manufactured . . . but not by us.

CAMERA CLUES

By Richard Horsfield

I have often been asked: "What is the best film to use in my camera?" The answer to that is a simple one. Load the camera with the film you have become accustomed to. By so doing, if you have been using the film correctly, you will have acquired a knowledge of what the film can do when matched up with your own camera.

I believe, however, that there is a tendency for many photographers to use film of a faster speed than is desirable for the subject that is being pictured. Black and white film in normal use is known as being panchromatic, which simply means that it is sensitive to all colours. Red, for instance, will show up in the finished

print, as being different in tone value, from either dark blue or black.

In my own case I use, almost exclusively, two makes of film; they are Ilford and Kodak, so we will in this short article concentrate on those two types.

ILFORD	Type	ASA Speed
Pan.F.	P.	25 uf
F.P.3.	P.	64 ef
H.P.3.	Pr.	200 mg.
H.P.S.	Pr.	400 mg.
KODAK		
Pan.X.	P.	25 ef
Plus X	P.	80 fg.
Tri-X	P.	200 mg.
Royal X	Pr.	670 mg.

Code: P - Panchromatic. Pr - Panchromatic with increased red sensitivity. uf - ultra fine grain. ef - extra fine grain. fg - fine grain. mg - medium grain.

I have chosen the above 35MM films because they are in common use and therefore well known to most people who make a hobby of taking pictures. It will be noticed at once that the slower the speed of the film, the finer is the grain of the emulsion that is to become the finished negative. Remember that the slower the speed of the film, a larger degree of enlargement can be made without unpleasant effects. Also the resulting image on a low-speed film has greater clarity and sharpness.

Slow films are rated as being from 20 to 40 ASA. Medium speed films from 50 to 80 ASA. Fast films from 100 to 200 ASA. Ultra fast films from 250 to 640 and above.

It will be seen from the foregoing that a wise photographer will choose his film speed according to the result he wishes to get and the size of the enlargement he will eventually make from the negative.

Slow films have many advantages but they cannot cope with bad lighting conditions nor with fast movement.

Medium speed films are suitable for all-round photography providing some care is given the condition of the lighting.

Fast and ultra fast films have very specialized purposes and should therefore only be used when the occasion demands it and nothing else will get the picture needed. Primarily their use is for high speed sports shots, poorly lighted interiors, stage shots. Fine effects can be obtained by using them for action night shots especially if the subject is a well lighted street with lots of neon signs. The best time for this is

after heavy rain when the wet road and pavements reflect the light.

For Your Bookshelf

RETURN TO THE STARS. Evidence for the impossible. By Erich von Daniken. Translation by Michael Heron.

The introduction to this book describes Swiss ufologist von Daniken as an "autodidact, which the dictionary defines as a man who is self-taught."

It continues: "The author of 'Chariot of the Gods?' (his first book) was barely nineteen years old when his curiosity first drove him to Egypt where he hoped to track down the real meaning of some cunieform inscriptions. Since his first journey in 1954, he hops on planes to clear up his theories the way we catch a bus."

For an autodidact and a ufologist (though we have not read anywhere that he calls himself one) von Daniken has come a long way. According to the publishers, 'Chariots of the Gods?' attained world sales of 750,000 in 1970. More recently a 1½-hour TV documentary on the book has been released which should boost sales well beyond that. (This documentary must surely rate as one of the most fascinating probes into antiquity ever filmed. We know of UFO skeptics who, having seen it, became believers just as completely as any diehard flying-saucer buff.)

But excellent as it was, von Daniken's first book had shortcomings quite apparent to anyone who has done much reading on the possibility of prehistoric visits from space. He left an impression of much second-hand information, perhaps involving good library research, but second-hand all the same. This is fair enough when there is no pretension otherwise - in fact, it would leave all of us in a very bad way if we couldn't "research" other works - but evidently von Daniken was disinclined to admit doing anything of the sort with the result that many of his supposedly on-the-spot observations seemed lifeless and unreal. Also he claimed as his own some ideas which certainly were not (that of mankind having ancestors in space, for instance - there must be half a dozen contemporary writers who can lay claim to a piece of this idea).

For reasons perhaps only the author knows, the approach in 'Return to the Gods' is entirely different which, in our opinion, makes it a far more readable book. While the original-thinker attitude faintly persists, and with some reason, there is no question of his personal knowledge of artifacts he discusses. As always, his conclusions about non-earthly workmanship are intriguing.

For instance, on stone balls in Costa Rica: "There hundreds, if not thousands, of artificial stone balls lie about in the middle of the jungle and on high mountains, in river deltas and on hilltops . . . I had heard about this sensation and because of it spent ten days in Costa Rica, a typical developing country (of Central America)

that has so far been shunned by the vast mass of students . . . One thing is quite certain. The balls cannot have originated without mechanical help. They are perfectly executed - absolutely spherical, with smoothly polished surfaces . . . I could not solve it but my suspicion increased that the prehistoric balls and all the pictures of them in reliefs and on cave walls are directly linked with the visit of unknown intelligences, of intelligences who landed on our planet in a ball."

On strange stone pipes in Tiahuanaco, Bolivia: "When I was able to examine the 'water conduits' . . . I found that what I had read about them was true. They had a completely modern shape with smooth cross-sections, polished inner and outer surfaces and accurate edges. The half-pipes have grooves and corresponding protrusions that fit together . . . Traditional legends and existing stone drawings tells us that the 'gods' met at Tiahuanaco, before man was even created. In the language of our space age that means that unknown astronauts constructed their first base on the Bolivian plateau . . . Looked at from that point of view, is it not more likely that the 'space conduits' were protective pipes for energy cables between individual buildings of the complex?"

Having said their piece in their first book, some authors have nothing to add in their second. Not so with von Daniken. More than ever we look forward to his third.

(This book first published in Great Britain 1970 by Souvenir Press Ltd., 95 Mortimer Street, London W. 1. and simultaneously in Canada by The Ryerson Press, Toronto 2, Canada.)

THE NEW FACE OF SCIENCE, By Fred Hoyle

In a recent issue (vol. 2, no. 1) Canadian UFO Report like two or three other publications carried an article attributed to astrophysicist Fred Hoyle which opened with these arresting lines:

"Human beings are simply pawns in the games of minds that control our every move. Our whole life and the complete existence of this universe is at the whim of these creatures that hold fantastic mental powers over us."

Did he really say that, and much more? Students of Hoyle were sure he did not and, as we reported, it seemed they were right when Hoyle's office described the whole story as "absolute fabrication."

But the thought persisted that these remarkable views in some way might be connected with his recent book, 'The New Face of Science.'

Now, after reading the book, we think the verdict favors the first opinion. Far from making any shattering metaphysical pronouncements, the book is a somewhat bland discourse relating scientific methods to social controls. Evidently it is based on papers that Hoyle has presented over the past several years, in no way suggesting the abrupt release of a radical idea.

But the verdict is not final, for there are faint hints of an inner stream of thought that is unlike what appears

on the surface. Here is an example, and with it we withdraw from the debate - until something else comes along:

"I am concerned with something coming through the walls (of our terrestrial box) that cannot be shut out, however much we might try - something that depends on the large-scale cosmological structure of the universe, something that comes from the *future*, not from the past . . . If it should turn out that you cannot engage in the simplest activity, like eating your dinner or smoking a cigar, without signals from the future as a controlling influence, then our whole philosophical attitude to the world outside the earth will be changed - markedly, I believe, over the next two decades. The issue, I believe, will be as important culturally as it is scientifically."

(This book is published by The New American Library, Inc. in association with The World Publishing Company. Published simultaneously in Canada by Nelson, Foster & Scott Ltd. First printing, 1971.)

HARMONIC 695. The UFO and anti-gravity. By B.L. Cathie and P.N. Temm.

Ever since reading his first book, 'Harmonic 33', we have been among those who believe that Bruce Cathie must be included among current UFO researchers most likely to ferret out a real clue to the mystery. Perhaps, in fact, he has already done so. He is a man capable of original thought - which this whole problem needs - and tremendous attention to questions at hand.

As his book-titles imply, Cathie's main approach to the enigma is via mathematics. Through this medium and a mapping of actual sightings, he has plotted a grid system which he believes provides guidance for all UFO activity around the world.

As he himself explains it:

"First of all, a geometric pattern of UFO activity was discovered which indicated a definite purpose in the presence of UFOs about our planetary surface. Having established the pattern of the grid, the next step was to break it down into mathematical coordinates. When this was done, it was found that all the values represented in the grid had direct harmonic relationships with the speed of light, gravity and earth mass.

"Once these relationships became clear it was possible to theorise on the method of propulsion employed by UFOs. It would appear that by setting up an harmonic imbalance of forces, the UFOs are able to reposition themselves in space-time; that is, the UFO moves from one point to another in order to restore the balance of forces caused by space-time geometrics . . .

"My findings led me to conclude, further, that volcanic activity, atomic disruption (nuclear bomb detonations) and earthquakes could all be related to the grid structure, an atomic bomb being a space-time geometric device, and volcanoes and earthquakes occurring on geometric points of the grid system, due to disturbances at these points."

There are questions about all this that nag us, such as how does Cathie plot a sighting when the observed object is in motion? Obviously he assumes it is pro-

ceeding from one point of imbalance to another, but when neither the beginning nor end of the flight is observed, how can he be certain these points fit into his grid? Also what about the thousands of reports from other countries that he never receives? Could these not provide a multitude of contradictions to his grid theory?

But let's not press the point. From the striking examples Cathie gives to support his theory, and his seeming prediction of incidents on the grid - including nuclear detonations - it appears he is on the track of something even though not all questions are answered.

The aspect of Cathie's work that to us does suggest a serious weakness is that he seems overly intent on making his grid account for every mystery that arises. As a result, he is apt to overlook important extraneous questions that should be asked in checking out a story. Surprisingly, because his new co-author Peter Temm is an experienced journalist, this weakness appears more strongly in his second book.

In particular, we have in mind a section he devotes to certain strange-looking wireless aerials observed on houses in Auckland, N.Z. Because these aerials resembled the polar patterns of his grid system and because their positions conformed with the grid, and were predictable on that basis, he proceeded to the remarkable conclusion they were part of a terrestrially-manned transmitting system for UFOs.

Aside from a Post Office check disclosing the aerials belonged to ham radio-operators and the discovery of a technical name for them, no other information is said to have been obtained about this gear with a "slick, sophisticated look." Apparently no excuse was found to question any of the owners, no attempt was made to find the manufacturer, no professional opinions were sought (except that of a U.S. specialist about a particular part of the equipment), and no inquiry was started to see if the aerials were located in other cities.

If it turns out the aerials are used in other parts of the world, Cathie will have the considerable job of proving a massive earth-bound organization exists to support operation of UFOs. If he succeeds, he will have the biggest news-story of the century. But if he fails, it does not mean the rest of his work also fails. In this business, guessing wrong is merely standard procedure.

(This book is published by A.H. & H.W. Reed Ltd., 182 Wakefield Street, Wellington, N.Z., or 51 Whiting Street, Artarmon, Sydney, Australia. First published 1971.)

FLIGHT TO THE STARS. An inquiry into the feasibility of interstellar flight. By James Strong, B. Sc. (Eng), ACGI, AGRAeS, FBIS.

In discussing space travel, some writers with a hard-headed engineering approach take the view it is better not to discuss it at all - or at least nothing that extends beyond our solar system. In their minds the problems of distance and time become so enormous they are soon presenting us with a tedious list of impossibilities and we are no better off for having picked up their books in the first place.

Not so with this author. Although far more cautious than a science-fictional type - sample quote: "yet even then, by A.D. 2140 or thereabouts, it would be

surprising if a propulsion system for star flight were to exist in embryonic form" - he presses forward into the imponderables and emerges with concepts like this:

". . . we have good reason to believe that a high proportion of the asteroids contain raw metal in the form of nickel and iron. Therefore, why not set up a fabricating plant (for a star ship) on the minor planet Ceres, which has a small gravity, no atmosphere, but lives at the very heart of the asteroid belt? Impossible? Well, remember this will not take place in the twentieth century, but the twenty-second, and interplanetary travel should be a whole lot easier by then."

Primarily this book is concerned with how to build such a star ship and then where to aim it. Naturally the selection of a goal must be quite vague at this stage, and well into the foreseeable future, so that Strong emphasizes this qualifying note:

". . . to arrive at a star, after wearying decades of flight, only to discover that none of its planets was suitable, would be a major disaster. The grim alternative - if there was one - would be to turn aside and head for the next star, possibly with similar results.

"Since mankind cannot afford to risk an abortive sortie of such a nature, we must face up to the problem fairly and squarely. Every interstellar expedition we send out must be capable of carving out for itself an artificial home, no matter how hostile the environment of whatever planets are available. No reliance should be placed on the finding of 'congenial planets' since, as we now suspect, their numbers are few and far between."

Strong's examination of stars that may invite exploration includes tables and diagrams which could serve as useful reference material to the student of space. While mainly occupied with man's efforts to launch his explorations, the author has the vision to concede others may have travelled the star route long before us. To quote:

"If we can assume that the majority of people know, or imagine they know, what a large interplanetary vessel would look like, this is a fair statement (in claiming instant recognition if they saw a star ship). We should expect a star ship to be much bigger, but it ought to conform to the shapes and sizes we associate with space-fiction illustrations. Again fair comment. Unfortunately this makes no allowance for what might be the end-product of a technological skill 500,000 years in advance of our own, and an interstellar vehicle belonging to such an era might be totally unrecognizable by today's standards. It could be a transparent bubble, twenty feet in diameter; it could well be a Flying Saucer! Sometimes it is a mistake to be too positive about something you have never seen."

(This book is published by Hart Publishing Company, Inc., 719 Broadway, New York N.Y. 10003, U.S.A. Price \$5.95. Copyrighted 1965.)

HYNEK BOOK PUBLISHED

In the last stage of preparing this issue we received a copy for review of Dr. J. Allen Hynek's keenly awaited book 'The UFO Experience.'

As all concerned with the UFO phenomenon well know, Dr. Hynek, chairman of the astronomy

department at Northwestern University, was official consultant to the U.S. Air Force throughout the existence of Project Blue Book, set up to receive and presumably investigate "flying saucer" reports.

In 'The UFO Experience' he says:

"Although my chief responsibility was as astronomical consultant, I concerned myself with all reports as they came in, each month reviewing current reports. Thus I became aware of some very interesting cases, most of which were submerged in a veritable quagmire of nonsense reports.

"The termination of Project Blue Book heightened my sense of obligation to set forth my experiences, many of them startling, with the UFO problem and with the Air Force over a period of more than 20 years. Now I feel somewhat like a traveler returned from a long journey through unexplored, strange and exotic lands,

who finds it incumbent upon himself to set down an account of his travels and of the bizarre antics and customs of the 'natives' of that strange land for the benefit of those who stayed at home."

Time is too short to discuss Dr. Hynek's fascinating and important experiences in this issue. We shall do so fully in the next, leaving our review on this note for the moment:

We are fortunate 'The UFO Experience' has happened in our time. Untold years from now other scientists who perhaps once thought of flying saucers as a joke will be moved to write a serious book on the subject. Dr. Hynek has anticipated them by just that much and given us the pleasure of seeing it done.

(This book is published by Henry Regnery Company, 114 West Illinois St., Chicago, Illinois 60610, U.S.A. Price \$6.95)

LETTERS

Sir:

I have read other UFO magazines besides Canadian UFO Report but yours tops them all. Enjoy it very much. So factual in every way.

Speaking of flying saucers or UFOs brings to mind an incident that I happened to witness many years ago in the Georgian Bay area of Lake Huron — Owen Sound to be exact.

Although it is still vivid in my mind, I do not recall the exact year. I was 11 or 12 years of age at the time so it must have been 1922 or 1923.

It was a warm summer night. The air was still and darkness had descended on our summer home. As on many another night, this particular evening I was outside on our porch listening to the night sounds and peering into the darkness when a sudden glow high in the sky directly overhead caught my attention. I moved to the edge of the porch for a better look and while I watched I saw there were clouds up there of varying density bathed in a yellowish orange glow.

My interest grew as did my curiosity and while I gazed I saw through a break in the clouds, and coming into full view, an oval-shaped orange-colored light, appearing flat on its bottom surface and moving in a northerly direction. There was nothing metallic in its appearance, no pulsating lights. Just a steady glow. It soon vanished and I thought no more about the incident.

As an afterthought, when one reads about government or government-financed investigating commissions and their findings regarding UFOs it sure makes one laugh the way they try to ignore the true facts regarding sightings by reliable parties.

Joseph Kovacs,
Hamilton, Ont.

Another early sighting in the same area was made in 1914 when a strange craft was observed with small humanoids aboard evidently drawing water from the lake. (See vol 1 no. 3. In the original report the lake was apparently named in error as Lake Ontario.) Also consider the similarity of the above description to this report carried in Norma Short's Skylook of last February concerning a photographer's recent experience in Poland: "A moment before I pressed the shutter release button, a gleaming

orange-yellow disc had sprung from behind the clouds, which at the time I had taken for the sun." The developed film showed a solid-appearing object.

Sir:

I have just been watching you on television and I thought I would mention an experience I had as a girl. It was in Downey, California, sometime around 1945. I don't remember the exact date.

It was just about dusk when I was on our farm feeding chickens. I looked toward the distant hills to the N.W. and saw a ball of fire moving slowly along the hills (they were about five miles away). It was so low and so slow that it couldn't have been a plane. I listened to the news and watched the paper for several weeks because my folks thought it might have been a plane on fire, but never heard a word about it.

It was so impressive that I have never forgotten it. I believe it was a UFO. But at that time I had never heard of them.

Mrs. J. Watson,
Cowichan Station, B.C.

Sir:

I have reason to believe there has been, and still is, a certain (maybe regular) amount of UFO activity going on near here for quite a number of years. Back in 1961 (Jan. 18 to be exact) about 10:00 p.m. I noticed some red lights behind some trees about one-quarter mile away to the east. They looked like the rear lights on a car, but they were bigger, and as they looked to be about three-quarters of the way up the trees through which I was seeing them, they could only be high off the ground.

The explanation at the time was an airport, and as Abbotsford airport is only about 14-15 miles, as the crow flies, from Langley, that explanation was accepted and from then on every time I saw these lights I automatically thought 'airport.' Until Sept. 23, 1970.

For the first time in quite a while I put my light out early, 10:20 p.m., and turned to look out of the window, and everything seemed to happen at once. I had just noticed the

lights when they seemed to quiver and began to grow bigger, and up over the trees appeared an oval shape which hovered for about two seconds then 'swam' off quite gently towards the N, or N.N.W. It was about the size of the full moon. I would say the basic color was the same as the moon's, but it was overlaid with a deep rosey glow which might have been caused by the glowing red lights which filled it. There was no fuzziness, the outline was clear and the whole sighting lasted about one and a half minutes.

I saw no more until March, 1971, and then for four nights (9th to 12th) I saw the red lights but nothing else. Then about Nov. 11, 1971, I was tired and had gone to bed about one hour earlier, 9:30 p.m., and as I looked out of the window I saw the same (or one similar) UFO 'swimming' back from the N, or N.N.W. It hovered over the same trees, sank down behind them, and there were the red lights again!

They were not there the next night and I haven't seen them since though I'm still watching. But on the morning of Dec. 11, 1971, at 3:15 a.m. I had to go down to the bathroom. On the way back I looked out of the front door window and there, in a different position, hovering way up above the far trees, was another oval UFO — same size, same shape, color more orangey and no red lights. It seemed to twinkle, but this could have been because I was viewing it through a leafless tree near to the house. It was still there when I got to sleep again but it was gone when I got up at 6:30 a.m.

All the same I couldn't get it out of my mind and, in between getting breakfast, I kept looking out of the window where I had first seen it. At about 7:30 a.m. when it was barely light enough to see the outline of the mountains, I noticed a broad, faint, pink glow in the direction the UFO could have gone. I got our binoculars and, focussing on the glow, I saw what can only be described as a glowing golden object sinking into either a very large open space surrounded by trees or down into a valley between two hills. (Having looked at the spot more than once since, I'm inclined towards the latter explanation.) Half an hour later there was nothing to be seen — except the mountains, of course.

I have seen nothing since in either direction but am keeping my eyes open every night without fail. I have no witness to the above and wondered if you had heard from any other subscriber describing the same or similar type of UFO. It would be nice to know I'm not the only one seeing these objects.

Anonymous,
Langley, B.C.

The writer has identified herself and the area concerned for our own records. We are satisfied she writes not to create a mystery but to find if other readers have had a similar experience, as indeed they have. The following letter is an interesting example, among others we have carried. Also we are now looking into the case of a reader who has seen not only a continuation of unexplained lights, but possibly "occupants" as well.

Sir:

My husband and I enjoy your magazine very much. It is very interesting reading, especially the editorials and drawings are good. I told you two years ago (see Letters, vol. 1, no. 5) when I saw a UFO between the peaks of Mt. Arrowsmith in 1962.

Meanwhile—but that is two years back—in May 1970 both my husband and I saw something that we at the time didn't think worth mentioning to you because my husband claimed it could have been a weather balloon. I will let you decide about it as it doesn't leave my mind.

We are living adjacent to the Englishman's River Falls Park. Our next neighbor to the north is 1½ miles off. From my

living-room window I am looking toward the south at the sidehills of Mt. Moriarty. I know when I look in that direction there might not be another human being before the Olympic Mountains (as the crow flies).

One night around 11 o'clock I looked out from a small room off the kitchen toward south-west and there I saw a red ball gliding along. It looked like a shining red round lamp. Nothing undulating, no noise — and it seemed to glide just above and between our fruit trees, very slow. I wasn't alarmed, I felt nothing. When I got my husband off his TV I just saw it disappearing behind a big tree. Very disappointing for me because I wanted my husband to see it.

The next week at around the same time I came into the kitchen and there the same ball was hanging between some cedar trees about 100 yards from the house, this time north-west. The first time I saw it it was flying from east to west. I was running in and out from kitchen to living-room, thinking "if I call Jack it will just have disappeared" and I waited for at least a half-hour before my husband came out (without my telling him). He burst out "What's that?" and now we watched that "lamp" for about five minutes and then it just seemed to fade away. My husband claimed it had something bluish while disappearing, but I couldn't see that. Funny thing, though, that we both had no feeling of fear or alarm being so alone out here in our wilderness. When I looked in daytime I thought it could of course have been much further away and much bigger than about the size of a football.

Another time in daytime and bright sun, around one o'clock, we both saw from the car a very bright nearly blinding light in those sidehills. We looked towards south, just passing our neighbor, and the sun was standing in that direction. I said "Maybe there is a logging road and the sun is shining on the windows of a truck," but my husband claimed that couldn't be possible.

Well, I have been reading about power stations for UFOs and all kinds of speculation, but don't you think that those advanced beings wouldn't need our electricity? That they on the contrary should know everything about us, as long as they seem to have been with us, maybe thousands of years? I really believe that the "sons of God" mentioned in the Bible came with those flying saucers. And that the universe can have so many far advanced civilizations that we see different kinds of vehicles and beings, maybe good and bad. . . for how can we explain attacks on people otherwise? If we were able to fly around the universe in the low state of advancement we are in now, wouldn't it be terrible for beings on other worlds?

I often have been wondering if telepathy is not really involved, even in our case here. I was so deeply disappointed when I saw that "lamp" flying through our garden (as it seemed) without my husband seeing it, and after I had been looking every evening again and thinking how wonderful it would be if he could see it, it came back and waited until my husband did see!

But why out here in this wilderness, if it really was a UFO? It was definitely not an airplane, the way it was moving very slow and quiet, and the next time just hanging between those trees.

Thanks for very thought-provoking reading. We wouldn't miss your Canadian UFO Report at all.

Mrs. Jack Graepner,
Errington, B.C.

In our first installment on the Canadian "flap" of 1967 (vol. 1, no. 6) we said: "Obviously a basic part of our space visitors' roving-eye equipment is the comparatively small ball of light, usually reddish in color." In one instance witnesses described a glowing blood-red object about the size of a soccer ball "moving so slowly there was plenty of time for many of us to see it." The

similarity between this account and Mrs. Graepner's speaks for itself.

Sir:

Your work is searching and encompassing and I hope through magazines like this we will eventually come to a closer understanding of this aspect of our existence . . . especially now, a very important one I think.

For years I have been interested in UFOs and other subjects dealt with in your magazine. Of specific interest is your current concern with UFOs in the Rocky Mountain Trench area. I, too, had an unforgettable sighting in the famous year of 1967 (August) over the Rocky Mountains. I saw five circular objects, definitely manufactured, clear and distinct, flying over the Rockies . . . one leading and four following in perfect diamond shape formation.

I wish there was someone in Vernon or in the Okanagan Valley I could speak to about this and other things that have come to my attention.

Chris M. Sissons,
RR No. 1, Northcott Dr.,
Vernon, B.C.

Sir:

In the remote northern region of Lac St. Jean, Quebec, the summer nights are cold due to piercing humidity, and so they were in June, 1971. But above, the sky was beautiful and cloudless, full of wonders.

My wife and I were then camping in the well-known national park, Val-Jalbert, which attracts many campers. One afternoon we visited the small town of Roberval, situated some five miles west from where we camped, on highway 55. After we had done with our visit, we decided to walk back since the skies were so magnificently full of falling stars.

The time was about 11 p.m. with not much traffic to be seen. We were amazed by the silence. All we could hear was crickets and our own footsteps.

At two or three miles from camp, a huge falling star, in the east, captured our curiosity. It wasn't any ordinary star because instead of swooshing across part of the sky and disappearing from view, it remained bright and moved much too slow. It went from one side of the sky to the other.

As the object passed above us, I noticed that it issued an orange pulsating dim light. I asked my wife if she saw any colors in particular besides the bright white glow. She said, "Orange seems the closest color I can relate it to!" I decided then that the object was not an airplane for to my knowledge planes do not carry lights of that color. Planes, too, are not as brilliant as this was.

The object, or star, seemed to glide as if on slippery oil, wavering from side to side, as it crossed the moon in the background. We heard not a sound whatsoever. In fact, the silence was spooky. The shape of the object wasn't clearly visible since its light was so brilliant. But I got the impression that it possessed a dome shape, which agreed with my wife's impression.

We watched the object cross the sky from the remote east corner until it disappeared towards the far west. As it disappeared, we were left there with our questions. Then continuing towards camp we heard the roar of an airplane crossing the sky—and it produced noise, unlike the object we had just seen. Also the plane was carrying red flashing lights, whereas the object had orange pulsating dim glows.

So the question still stands: "What was it?"

James Richards,
Jonquiere, Que.

Sir:

Last Dec. 14 at approximately 9:00 p.m. I was travelling by auto north on Interstate 17 between Phoenix, Arizona and Black Canyon (the sky was good for astronomical observations and I had stopped a few minutes earlier to look at nebula M31 through my binoculars) when I noticed what looked like a low meteor in the upper left of my high windshield.

A few seconds later, maybe three or four, another one came from the right, arced down to the lower left, made a horizontal swing forward and then slowed down, apparently heading toward the shrubby brush on the left of the four-lane freeway. That was my impression, but I did not slow down for a search because of the cold, and it was late.

Now the event seems peculiar to me. Meteors have a blue-white light, as the first one did. But the second started with a dim reddish light and lit up blue-white as it changed direction. What is more it appeared to be only 1,000 feet ahead of my car. It reminded me of the flight of certain birds when they become curious about a moving object.

The object could not have been a shot from a Very pistol because the wind was blowing gently in the opposite direction. It landed against this gentle wind, so to speak. I estimated both objects to be three or four inches in diameter.

M.V.,
Vancouver, B.C.

Sir:

There is a very interesting book from Germany, for German-speaking readers. I educated my children by it when they were younger. It is 'Aus fernen Welten' ('From distant Worlds') by Bruno Buerge; 559 pages, with sketches, photos, tables. Editor and Publisher: Ullstein Verlag, Berlin, Germany. It is a very stimulating book about the heavens — "Outer space for everybody."

By 1939 over 100,000 copies were printed. Then by re-arrangement it was published by Deutscher Verlag, Berlin. After the war there was a re-opening of the publication house, Ullstein Verlag.

This is a book for everyone, for all ages.

Mrs. Hildegard Lindeman,
Vancouver, B.C.

Does anyone know if this book is still being printed or if copies from the original printing are still available?

Sir:

I've just come to live and work in Vancouver and I was glad to see your magazine. I'm among friends.

For nearly two years now I have been studying My Contact with Flying Saucers by Dinó Kraspedon, the Brazilian. I have taken the book to various authorities and have been unable to obtain any satisfactory answer except that the ideas propounded in the book conflict with theories accepted by the majority of Earth's scientists.

I have written the Soviet Academy of Science seeking confirmation that they published in 1957 a paper on the Repulsion of Solar light. I have had no reply. I have written a Major Seversky who patented the Ionocraft in the early sixties, a craft similar I believe to the one described in the book. I have had no reply. I have been to the Dunsink Observatory in Dublin asking them to look over the book and also tell me if there was any unusual activity in the Cancer area of the sky; the direction in which the second Sun is to come. I was told the book was preposterous and that I should not waste my time. I have written to the Chinese Communist Consul in London seeking

information on a new hormone called gibberellin being used to fertilize Chinese plants: the existence of such hormones is described in the book. I have had no reply.

The only confirmation I have had about the book's contents is a one-page section on sleep-learning which has been described by a noted authority on the subject as true.

I believe myself that the book is true and have endeavoured to live by it and in doing so I have broadened my understanding of our milieu.

I would like to know if any of your readers have read the book and what progress they have made with it.

John Roughneen,
Vancouver, B.C.

In UFOs: Operation Trojan Horse author John Keel says of My Contact with Flying Saucers: "It was first published in 1959 and was largely dismissed as just another piece of crackpot literature. However, a careful reading reveals a thorough knowledge of both theology and science, and many of the ideas and phrases found only in the most obscure occult and contactee literature appear here. Among other things, the book also discusses an impending cosmic disaster in lucid, almost convincing terms: the same kind of warning that is passed on to every contactee in one way or another."

Keel relates that in a telecast in Brazil, Kraspedon predicted the assassinations of Martin Luther King and Robert Kennedy. But later he was arrested for being ring-leader in an outbreak of violence which he also predicted! His real name was revealed as Aladino Felix and he claimed to have had personal contact with visitors from space.

We would welcome any further comments about this man or his book.

Sir:

As I was checking and rereading through my back copies of the Flying Saucer Review (published in London, Eng.) I came across a very unusual and extraordinary article printed in the Sept.-Oct., 1955 issue. I have made a photostat copy of the two-page article and I am sending it along to you.

Nicholas Nestor,
Cleveland, Ohio

Written by Meade Layne, then president of the Borderland Sciences Research Association of San Diego, Calif., the article discusses a theory that people identified as Etherians construct a space craft by first "isolating a cube of space, or ether, to a very low vibration frequency. This etheric substance is then given the desired form. . ."

The article continues:

"When the 'ship' is completed, it is positioned by mental means — 'teleportation' — in any desired location, as, say, in the vicinity of our earth. So far, neither the ship nor any of these operations would be visible to us. But if the frequency of the etheric matter is then converted to other specific rates, the ship will, or may, become visible and tangible to our senses. But there is NO 'crossing of space' involved at any time. There is simply a change of location—and this is equivalent to a change of frequency or a conversion of vibratory rates.

"This last principle cannot be reiterated too often. It is basic to any understanding of the whole mass of aeriform phenomena.

"These huge craft may be miles in dimension, or even of planetary size—hence the feasibility of an 'evacuation of the planet,' if necessary. Under what conditions these huge objects, hanging hundreds of miles overhead, are converted to a frequency rate perceptible to us is, of course, unknown. But

discs and other forms discharged by the mother ships are obviously so converted, in order to operate under gravitational and magnetic conditions peculiar to our planet. Or it may be a part of the overall plan that those objects be made visible and tangible to us, as part of the education of earth people."

Sir:

The enclosed cutting (about Japanese war survivor Sgt. Shoichi Yokoi, see footnote) may not have too much significance. But consider. . . this man was quite familiar with airplanes as he saw them used in World War II. . . he has not lived the life of a hermit. For the past 28 years he has used his wits; his keen sense of observation and ability to remain alert kept him alive. Why then would he refer to, let's say, a jet aircraft as a "strange flying object"? After all, the basic outline has not changed since this soldier's war days. Only the propellers have been dispensed with; engine housing, body assembly, tail unit are all basically the same.

I put it to you that possibly this quote may have more significance than at first appears . . . then again maybe it hasn't.

Gentlemen of the jury, I leave it to you.

G. Conway,
Delta, B.C.

Here is the quote: "Yokoi also expressed disbelief when told a jet plane could take him in hours to his home in Nagoya. He wasn't sure what jets were but suspected they were the 'strange flying objects' he saw from hiding spot deep in the jungle."

Comments, anyone?

In a second letter, keen-eyed reader Conway drew attention to the extraordinary similarity of a UFO seen at McMinnville, Ore., in 1950 (vol. 1, no. 5, p. 24) to one observed in Norway in 1970 (vol. 2, no. 3, p. 27). See sketches below.

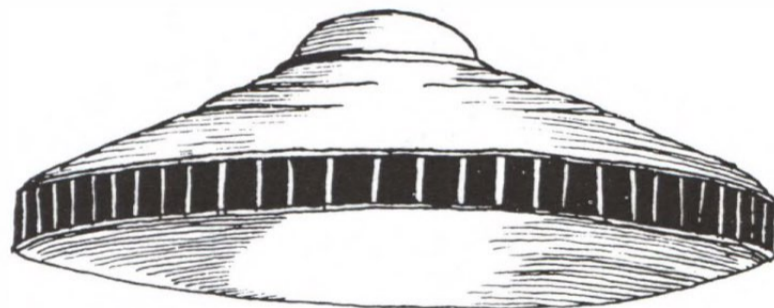

OREGON

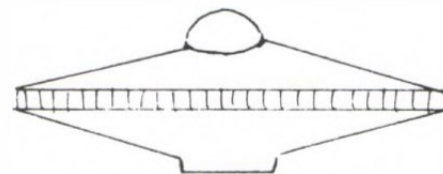

NORWAY

Sir:

It has been with genuine regret and a great deal of frustration that I was unable to continue with the publication of TOPSIDE due to my husband's continued heart trouble and to personal incapacity caused by two accidents.

In early November, 1971, my husband suffered an acute coronary and while he was in hospital, I had a bad fall in which I broke both bones in my right arm and badly sprained my left

wrist. My husband now faces the prospect of open heart surgery as his only hope of survival and I would deeply appreciate your prayers for his recovery.

When I have recovered from my own injuries and am able to type again, I still hope to continue with publication of TOPSIDE, and in the meantime, I wish to thank sincerely all those of my readers who have borne so patiently with the long but unavoidable delay and to express my gratitude to the many editors who have so kindly and faithfully continued to send me their exchange publications.

I send best wishes to all my good friends and may God bless you one and all.

Carol Halford-Watkins,
Aylmer East, Que.

As editor of Topside and North American coordinator for the UFO Petition to the UN, among other projects, Mrs. Halford-Watkins has contributed notably to the UFO scene. We wish her well in returning to full activity soon.

Sir:

Professor J. Allen Hynek was in Toronto recently to address a meeting arranged by Dr. A.R.G. Owen, director of New Horizons Research Foundation and Toronto Society for Psychical Research. His talk covered briefly such topics as his personal interest in unidentified aerial objects, his position as adviser to the U.S. Government on such reports, the present status of the UFO enigma and his admiration for the tenacious in-depth research methods of investigations conducted in France. A highlight was a slide presentation of his soon-to-be-released book, 'UFO Experience, A Scientific Inquiry.'

The next day Professor Hynek met with an informal gathering of the New Horizons UFO study group. During this discussion the subject of lenticular clouds, foggy conditions as reported by motorists on observing unconventional craft and mist-like rings surrounding these objects. It then occurred to the writer: Is there a relationship here with water-borne UFOs (four Canadian cases come to mind) drawing up water with a hose-like appendage? This may be a water intake or discharge for cooling or flushing, or alternatively the operators may, for the purpose of obscurity or deception, emit a vapor or cloud-cover forming a natural-appearing cloud. Numerous incidents of this nature, world-wide in scope, have been reported by various publications.

Henry W. McKay,
Agincourt, Ont.

Spookiness Explained

In captioning pictures of the Mariner 9 flight to Mars in our previous issue we included reference to a "spooky development" during the flight as described in a newscast from Toronto. According to this report, Mariner 9 rotated away from its fix on the star Canopus because it was influenced by an "object about 100 times as bright. . ."

In search of an answer to the mystery, UFO author Arthus Bray of Ottawa addressed an inquiry to Dan Schneiderman, manager of the Mariner project at the C.I.T. Jet Propulsion Laboratory in Pasadena. He received this helpful reply:

"First, let me describe briefly the design of the spacecraft. . .

"The spacecraft is oriented in space with one axis

(roll) pointed towards the sun, and another axis, perpendicular to the roll axis, pointed towards a star. In the case of the Mariner 9, the star Canopus is used as reference. To accomplish this pointing, a star sensor was developed which is like a small telescope mounted to the side of the spacecraft. After the spacecraft is pointed towards the sun, it is rotated about the roll axis until the star sensor sees Canopus, which is distinguished by measurement of the star's intensity. Once Canopus is in the field of view, the spacecraft's motion is stopped automatically, and the spacecraft's attitude is now fixed in space and continues to hold a fixed attitude relative to the sun and the star.

"The 'event' to which your question is directed occurred on 2 November 1971 and was caused by some light source entering the star sensor's field of view and briefly distracting the spacecraft's pointing towards the reference star. This did not change the flight path of the spacecraft, but only caused it to rotate in roll from the star. When this occurred, radio signals received on Earth indicated the spacecraft was rolling slightly. Signals were transmitted back to the spacecraft which permitted it to continue to roll until Canopus was once again in view. Once Canopus came into view, the spacecraft stopped and normal operation was resumed.

"This type of event is not surprising, and such events occur several times during a mission. Similar events were observed during the 1964 mission, as well as 1967 and 1969 Mariner missions. This is believed to be most frequently caused by small particles of dust detaching themselves from the spacecraft and drifting into sunlight in front of the star sensor.

"In this particular event, the particle had about the same light intensity as Canopus and therefore distracted the spacecraft briefly. Analysis and testing have both been applied to prove this as the most feasible explanation.

"I trust this will answer your question. To date, the Mariner 9 mission has been very rewarding, as there have been some 5000 pictures received as well as a great deal of other scientific information, and the mission continues."

While it was obviously impossible to be sure beyond all doubt that the distracting light was not something other than a stray particle, this reply has more to support it than do vague conjectures about a "spooky development." Full marks go to reader Bray for an intelligent follow-up.

MEETINGS

A wide ranging list of subjects featured talks and slides presented at the International UFO Bureau's Third Annual Symposium in Oklahoma City, March 24-26. Encouraged by success of the program, Bureau directors have plans for a still more ambitious symposium next year.

In order of appearance, speakers and their subjects

were:

Dr. Barry H. Downing, author of *The Bible and Flying Saucers: "The Red Sea Miracle."*

John Magor, publisher of *Canadian UFO Report: "UFOs: A Publisher's Report."*

Walter H. Andrus, director of Midwest UFO Network: *"UFOs: A Photographic Analysis."*

Stanton T. Friedman, director of California UFO Research Institute: *"Science and Saucers."*

Ted Phillips, Midwest UFO Network investigator: *"UFOs: The Physical Evidence."*

Sherman Larsen, president, NICAP — Chicago Affiliate: *"Documentation — Evidence of Government Concern."*

Dr. R. Cedric Leonard, author of *Flying Saucers, Ancient Writings and the Bible: "UFOs in Antiquity."*

Concluding the program, Tommy Blann, Bureau director in Texas, discussed two recent UFO photos taken at Mart. (See report elsewhere in this issue.)

Bureau directors Hayden Hewes and Dan Garcia officiated.



Scientists of Australia and New Zealand took a major step in the promotion of UFO research when they went on record as favoring a scientific examination of the subject and urged establishment of a committee of their own to study UFO reports.

The move followed a symposium at the University of Adelaide last October organized by the South Australian Division of the Australian and New Zealand Association for the Advancement of Science (ANZAAS). Attended by 300 scientists and others, the meeting carried a motion which read:

"The Symposium as a group feels very strongly that some action on the problem of UFO reports be taken. The Symposium unanimously requests that the Executive Committee of ANZAAS (S.A. Division) discuss the possibility of acting as referees for any qualified person or institution who is making or may make a submission for funds for the scientific investigation of UFO reports. It is further requested that the possibility of setting up a sub-committee for the study of UFO reports be considered by the Executive Committee of ANZAAS (S.A. Division)."

A report on proceedings of the meeting added:

"The motion was considered by the Divisional Committee of ANZAAS in the first week of November. The Committee felt that in the light of available information, the Symposium, and other evidence, there was sufficient evidence to show that there were sightings and evidence of phenomena which had not been adequately explained. There was a need to investigate these and they constituted an unsolved scientific problem as there were not answers under current hypotheses.

"As a result, the motion from the Symposium was favoured. The next step was to examine the feasibility of establishing investigation into and the appointment of scientists to look into the UFO problem, provided the money was available, ANZAAS would be prepared to appoint scientists from over Australia to do this research."

For those interested in a recording of the occasion, one tape of the full proceedings—either two-track at 1-7/8 ips or four-track at 3% ips—is available. This, plus a copy of the

Symposium condensed papers and 86 quarto pages of reports by Dr. James McDonald, may be purchased for \$17.00 Australian, postage included. Write: Owen Davis, 25 Hyland Terrace, Rosslyn Park, South Australia 5072, Australia.



Although delivery of this issue may in some cases be later than the meeting date, it is appropriate to record program details of the Third Annual Midwest UFO Conference for June 17 at Quincy, Illinois.

After a welcome by Walter Andrus, Jr., Midwest UFO Network director, keynote speaker will be Charles Barnum, executive editor of the Quincy Herald-Whig, on "UFOs as Viewed by the News Media." Other speakers in the morning session will be John Schuessler, Missouri director for MUFON, on "UFOs — A Product of Alien Intellect"; and Joseph Brill, MUFON field investigator, on "UFOs Behind the Iron Curtain."

Afternoon speakers will be: Ted Phillips Jr., central Missouri state-section director for MUFON, on "Landing Traces, Physical Evidence for the UFO"; Dr. R. Cedric Leonard, MUFON consultant in anthropology, on "UFOs in Antiquity"; and Brad Steiger, author, on "Flying Saucer Missionaries."

Featured speaker that evening will be Dr. David Saunders, psychology professor at the University of Colorado and co-author of "UFOs? Yes!" who will discuss "New Lines for Orthoteny in UFO Research."

A panel discussion and question period will follow, with William Schelen, chairman of Tri-State UFO Study Group, as moderator.

SS & S SUBSCRIBERS

Further to the announcement by Gene Duplantier that he is discontinuing publication of *Saucers, Space & Science*, we wish to advise his subscribers we have the privilege of transferring their names to our mailing list to provide continued UFO reading. All will receive this issue of *Canadian UFO Report* without extra charge. Mailing of future issues will be carried out on the same basis according to the length of unexpired subscriptions. Before expiry of a subscription, each SS&S subscriber will receive a reminder notice and renewal form.

SS&S, with headquarters at Willowdale, Ont., ceases publication after 15 years on the UFO scene. Explaining the move was necessary to allow more time for other interests, Duplantier added in a note to us:

"I am not getting out of ufology entirely. In fact, I may put out a newsletter consisting mostly of newspaper clippings received here of interesting items which may prove useful to editors of ufazines. This would be on an irregular basis, however, depending on how much useful material was received here."

Duplantier, pioneer UFO publisher in Canada, promises to keep in touch with us about any sighting reports of significant nature that come his way. All this is welcome assurance that he will remain active in UFO affairs.

ANNOUNCEMENTS

NEW SUBSCRIPTION RATE

Effective with our next issue, a new subscription rate will apply. The rate will be \$5.00 for six issues instead of \$3.00 for four. The purpose is to cut down frequency of renewal reminders which we trust will be more convenient for subscribers as well as for us. By this arrangement, each subscriber will receive a reminder notice with the sixth issue of his subscription, instead of the fourth as at present.

Special Ad Rate

Because of inquiries received about classified advertising rates, we have introduced a "one-inch special." Leave the size of type to us and say what you want to say in a single-column one inch ad. Maximum number of words is 50.

First-comers are listed below:

Here is a top selection of books by SCIENTISTS ON UFOs:

"An Analysis of Blue Book Special Report No. 14" by Dr. Leon Davidson, Price \$5.25.

"The UFO Experience" by Dr. J. Allen Hynek, Price \$7.25.

"UFOs: Myth and Mystery" by physicist S.T. Friedman, Price \$1.00.

All books postpaid from UFO Research Institute, P.O. Box 941, Lawndale, Calif. 90260, U.S.A.

Flying Saucers Over Quebec Canada. A new, authoritative, paper reporting, evaluating, strange phenomena. FULL of BRAND NEW AUTHENTIC PICTURES of BIZARRE LITTLE MONSTERS, LAKE PLUNGING DISKS, observations of MOTHER-SHIPS in OPERATION RESEARCH, CONTACTS and SIGHTINGS NEVER BEFORE RECORDED!!! Send \$2.00 for 12 issues to: COSMOS-EXPRESS, P.O. Box 3, Jonquiere, Quebec, Canada.

To ensure you receive every issue of Canadian UFO Report, please send \$5.00 and your name and address to:

Canadian UFO Report,
Box 758,
Duncan, B.C.

NOTE:

Please advise any change of address and avoid loss of a copy.

LANDING TRACES?

Readers with information on cases involving burned circles, "nests", footprints, craters, etc., please write: Ted Phillips, P.O. Box 615, Sedalia, Missouri 65301, U.S.A.

Have you heard of Baha u Ilah? Over one hundred years ago He predicted inter-planetary travel would be realized before the end of this century. Who was Baha u Ilah? For further information please write to me. Reta Gunnlaugson, 1570 Seventh Street, Brandon, Manitoba.

For up-to-date reports on new and significant UFO cases read SKYLOOK, official publication of the Midwest UFO Network. Editor and publisher of SKYLOOK, a monthly, is Mrs. Norma E. Short. For your subscription write: SKYLOOK, Box 129, Stover, Mo. 65078, U.S.A. Price \$4.00 a year.



CICERO AUGUST

INDIAN ARTS & CRAFTS

P.O. BOX 297
DUNCAN, B.C.
PHONE 746-7852

Price of the one inch special for one issue is \$5.00. (Two-inch space, run as a single ad, is \$10.00.) Simply type or write neatly what you have to say, up to 50 words, and send your ad to: Advertising Manager, Canadian UFO Report, Box 758, Duncan, B.C. Your cheque or money order must be enclosed.

We also have display advertising rates available on request.

Canadian UFO Report,
Box 758, Duncan, B.C., Canada
Please send Canadian UFO Report
for (six issues) to:

NAME

ADDRESS

CITY

PROVINCE

DATE

Cheque or money order, payable to Canadian UFO Report, enclosed for \$5.00 Price outside North America \$6.00. Back copies \$1.00 each.

It's THE CANOE STORE

THE CANOE



for the finest merchandise in all of North America.

We specialize in:

Sealskin Coats, Hats, Purses, Gloves, Mitts and every other thing made from this beautiful mature Newfoundland fur.

Imported Icelandic Parkas, Coats, Ponchos, Sweaters, Pant Suits, Skirts and Blankets. This is beautiful merchandise hand made from Polar sheeps wool.

Genuine Cowichan Indian Sweaters, Toques, Tams, Mitts and Sox. Moccasins. We carry the largest supply and variety of moccasins in Canada.

Wall tapestries imported from Italy.

Our merchandise is all Indian made, Canadian Made or Imported.

Send for our catalog. We ship anywhere in the world (by UFO). Tell us what you want. We will try to get it for you. Chargex and BankAmericard good for all purchases.



Dept. 'M'
The Canoe Store Ltd.
P.O. Box 550
DUNCAN, B.C.
Telephone 604 - 746-5614