

ANCIENT SKIES

"Come Search With Us!"

Official Logbook of the Ancient Astronaut Society

(c) COPYRIGHT 1979 ANCIENT ASTRONAUT SOCIETY - ALL RIGHTS RESERVED

VOLUME 6, NUMBER 3 1921 ST. JOHNS AVE., HIGHLAND PARK, ILLINOIS 60035 USA JULY-AUGUST, 1979

A TECHNICAL INTERPRETATION OF THE PALENQUE RELIEF

BY LASZLO TOTH*

In 1952, the Mexican archaeologist, Alberto Ruz Lhuillier discovered in a pyramid at the ancient Mayan ruins of Palenque, one of the most beautiful reliefs in the world (Fig. I). The explanation of the relief has been the subject of fierce debate among both experts and amateurs alike. The following suppositions have been available until now:

- a. It is a sacrificial figure having his heart removed according to religious custom.
- b. It is a pontiff who is standing in front of the symbol of the Maize-god.
- c. It is a native ruler sitting on his throne and gathering the fruit of the tree of life.
- d. It is Pacal, the great ruler, who in the moment of death is falling into the jaws of a mythological monster.
- e. It is an astronaut in his spaceship, according to Erich von Daniken.

By what principles can we begin the interpretation of the relief? Since physical laws are the same throughout the universe, we can discover many parallel features in the development of two civilizations. One's technical tool may be similar to the other's, because the inventors followed the same principles. Technology repeats itself!

The current official interpretation by the experts is that the relief represents Pacal, ruler of Palenque, who died in 683 AD "from the very hot wind." But let us translate this into technical language.

The inquisitive Pacal dared to approach the launch site of the spaceship and when it blasted off, the glowing exhaust gases killed him. So there was an accident! According to the Mayan priests, Pacal's soul was raised up to heaven with the missile. Since the Mayans could tell the story only in symbols, his figure was carved into the stone.

It is interesting that Pacal's figure is very large in relation to the missile, but it must be remembered that the relief was carved by Mayans, who presumably did not understand astronautics. Let us remove Pacal from the missile regardless of the symbols. Now, let us draw the visible edges and outlines and lay the astronaut into his seat. The picture changes immediately (Fig. II).

*An engineer, Mr. Toth was a speaker at the Third World Conference of the Ancient Astronaut Society in Crikvenica, Yugoslavia in 1976. He lives at 8800. Nagykanizsa, Oswald ut. 43/2, HUNGARY.

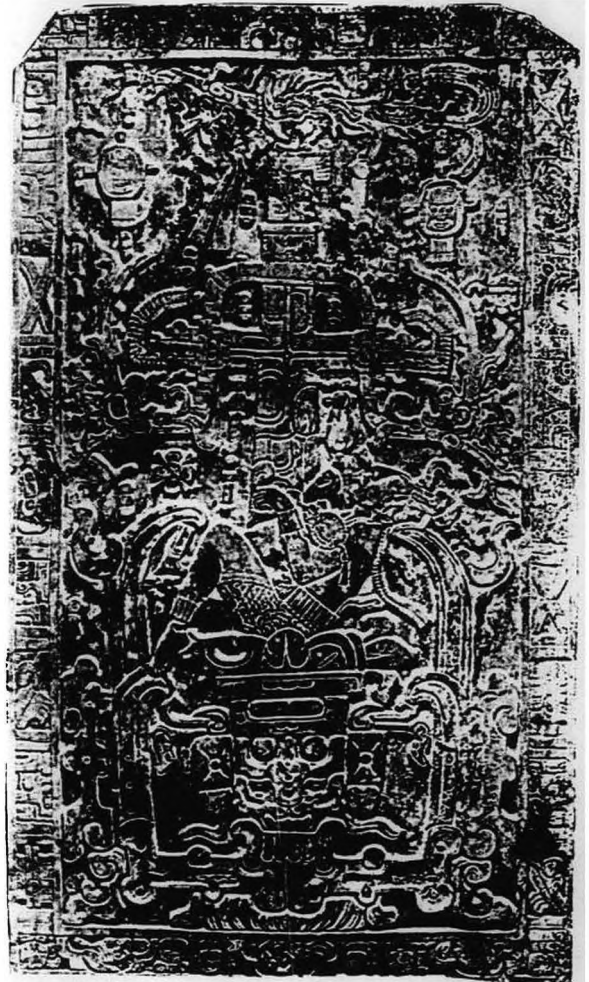

Fig. I. Relief carved into stone sarcophagus lid. Temple of Inscriptions, Palenque, Mexico.

The spherical arched double-walled containers are very interesting. Since it is supposed that they technically produce a vacuum, it is evident that there is fluid in the containers, probably hydrogen, which has the greatest energy content.

(Continued on next page)

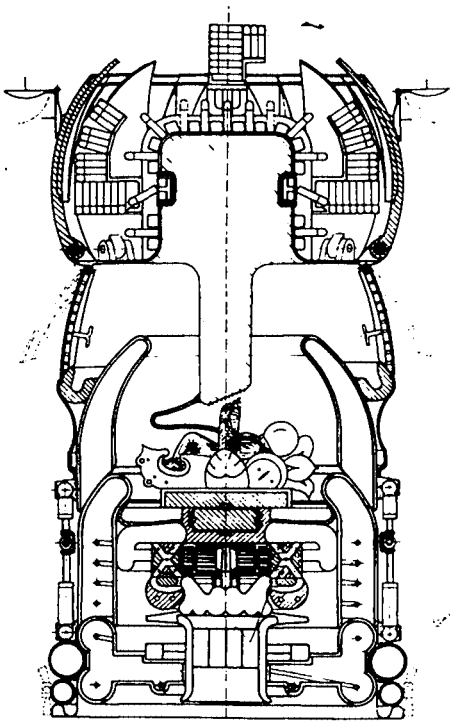

Fig. II

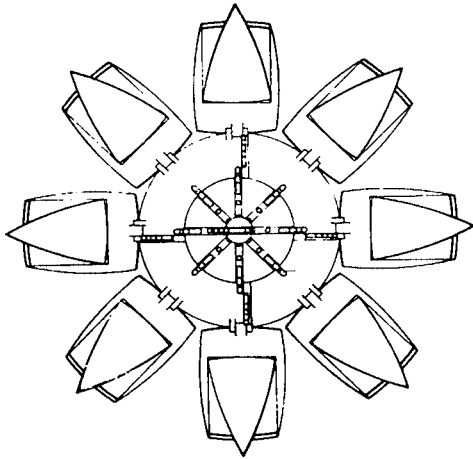

Fig. VII

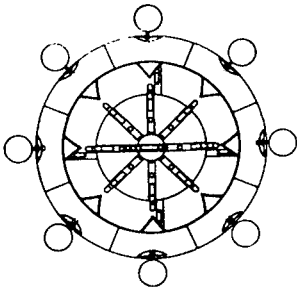

Fig. III

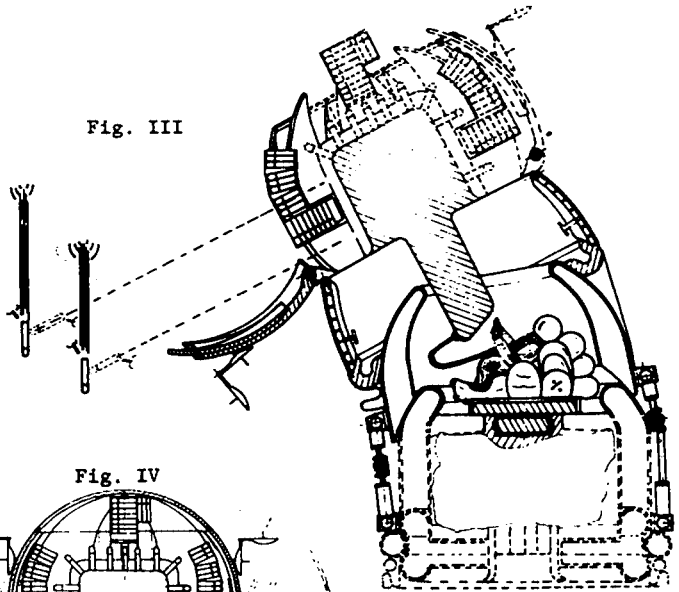

Fig. IV

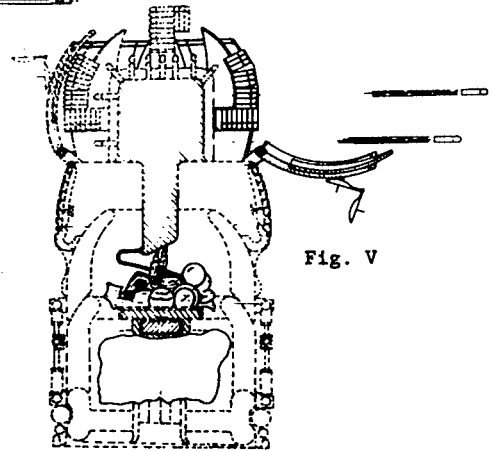
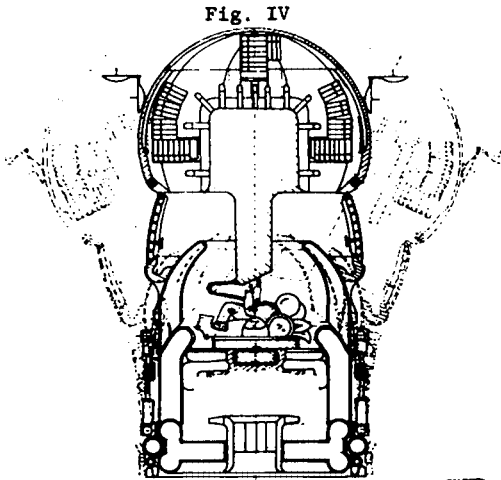

Fig. V

ANCIENT SKIES is published bi-monthly by the ANCIANT ASTRONAUT SOCIETY, 1921 St. Johns Ave., Highland Park, Illinois 60035 USA, for distribution to its members. Telephone (312) 432-6230.

The Ancient Astronaut Society, founded in 1973, is a tax-exempt, not-for-profit corporation organized exclusively for scientific, literary and educational purposes.

THE SHIVALINGA

BY BHALCHANDRA PATWARDHAN*

The Shivalinga is an object of worship dedicated traditionally to Lord Shiva and held in great veneration by all Hindus. In the form in which it is used and worshipped today, it consists of an elliptical platform, the "Shālunkā" with a vertically embedded ellipsoid, the "Bān" (See Figure A). On the ellipsoid are engraved a section of a helix, the "Tripundā" and below it a coiled serpent that forms another helix around the Bān.

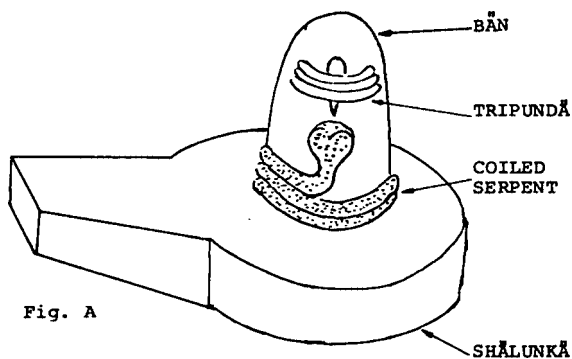
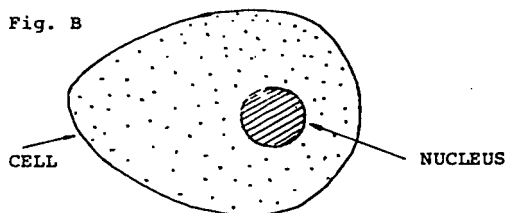

Fig. A

Fig. B



If we compare the form described above with the empirically backed, now-accepted structure of the Cell, we are bound to find a great number of parallels. Figure B roughly depicts an elliptical cell, which is formed around the focal nucleus. The base of the Shivalinga resembles roughly the overall shape of the cell with the Bān corresponding to the nucleus, situated at one focus of the ellipse. The Bān can be considered to represent the nucleus.

W. Fleming in 1880 discovered that the nucleus contained material which he called "chromatin", from its property to pick up red dye. During "mitosis", or cell division, this chromatin forms itself into threadlike bodies which he called "chromosomes." At the crucial moment before cell division, each component filament of the chromosomes pulls itself apart from its counterpart thereby maintaining the original balance even after mitosis. Somehow, before mitosis, each chromosome produces a replica of itself by a process known as "replication." Crick and Watson, in 1953, working backward from X-ray Diffraction data collected by M.M.F. Wilkins, advanced their famous theory of nucleic acid structure. They concluded that nucleic acid is made up of two interlocking helical chains of polynucleotides arranged symmetrically about a central axis.

In the Shāntiparva Book of the Mahābhārata, the great Rishi Vasishtha explains the creation of life on Earth to King Janaka. He says that Shiva is formless, indestructible and energized.

He has no beginning and no end. (Law of Conservation of Energy?). Shiva gives birth to Hiranyagarbha, which is the beginning of all life. It pervades the entire Universe, and yet is itself minutely small. It is self-creative and filamentary in form. In the Dronaparva Book of the same epic, Shiva is said to have four heads disposed in four directions and each head is said to have three eyes. What does all this mean? Let us examine these references.

Shiva's energetical property is clearly described and the Law of Conservation of Energy is also hinted at. Einstein has shown the equivalence of energy and mass by his famous equation: $E=MC^2$. Energy (Shiva) therefore gives birth to Matter (Hiranyagarbha), which is nothing other than the very basic ingredient of all life - the DNA molecule. It is found in all forms of life, and is yet microscopic. The chromosomes are self-creative since they replicate. They are also threadlike or filamentary. Shiva's four heads refer to the nucleotides that form the molecule, namely deoxyadenylic acid, deoxyguanylic acid, deoxycytidylic acid and deoxythymidylic acid. Shiva is described in some writings as polyhedral, and recent developments in genetics have shown the existence of not merely four, but anywhere from 200 to 2,000 nucleotides! The three eyes refer to the components of the helix, namely the polynucleotide chains made up of a sugar-phosphate backbone interlocked with purines and pyrimidines. Are these the same helices depicted on the Shivalinga? Most certainly they are.

Ancient Indian sages and rishis discovered this truth milleniums ago. In order to teach their pupils and to render the process of teaching easier, they must have constructed symbols and models of the DNA structure. In their model, the cell is represented by the Shalunka, the nucleus by the Bān, and the double helix by the Tripundā and the coiled serpent. The Shivalinga may thus be considered to have been originally designed to serve merely as a teaching aid. Later generations forgot its true meaning and purpose, and continued to blindly worship it as an idol of Shiva.

It has been my endeavor to render an account of what has appeared to me to be the truth. I invite interested readers to comment on this discussion so that through a process of constructive criticism we may be able to arrive at the objective truth.

*Mr. Patwardhan lives at Kurundwad House, 10 A, Mangaldas Road, Pune 411 001, INDIA.

CONGRATULATIONS TO ULRICH DOPATKA

Professional librarian and author, Ulrich Dopatka has compiled the first encyclopedia in the ancient astronaut field. The Lexicon Der Prā-Astronautik contains 448 pages with over 3,000 definitions, 284 black and white photos and illustrations, and 16 full color photos. The work includes biographical sketches of all the personalities in the field, as well as presenting the full spectrum of all the theories advanced by the more than 300 publications on the ancient astronaut theme.

The monumental work is available in the German language from the publisher, Econ Verlag, Dusseldorf, Germany.

We hope that a similar work can be developed in the English language.

Mr. Dopatka lives at Gartenweg 16, CH-4310, Rheinfelden, Switzerland.